



ORIENT DISPLAY

Your Total LCD Solution Provider

Specification for TFT

AFL240320A0-2.8N12NTM-ANO

Revision V0



A	Orient Display
FL	TFT Type
240320	Resolution 240 x 320
A0	Serial A0
2.8	2.8", Module Dimension 52.0 x 83.0 x 6.0 mm
N	TN Display
12	12 O'clock Viewing Direction
N	Top: -20~+70°C; Tstr: -30~+80°C
T	Transmissive
M	Normal Brightness, 300cd/m2
/	Controller ILI9341V
ANO	SPI Interface + compatible Arduino



DOCUMENT REVISION HISTORY:

DATE	PAGE	DESCRIPTION
2020.10.3	-	First release

Contents

1. General Specification
2. Mechanical Drawing
3. Block Diagram
4. Interface Pin Function
5. Absolute Maximum Ratings
6. Electrical Characteristics
7. Optical Characteristics
8. Timing Characteristics
9. Standard Specification for Reliability
10. General Precautions
11. Specification of Quality Assurance
12. Packing Method

1. General Specification

Item	Dimension	Unit
Module dimension	52.0 x 83.0 x 6.0(MAX)	mm
View area	44.8 x 59.2	mm
Active area	43.20 x 57.60	mm
Dot pitch	0.18 x 0.18	mm
Number of Dots	240(RGB) x 320	dots
LCD TYPE	TFT, Transmissive	
Top Polarizer Type	Glare	
View direction	12:00	
Drive IC	ILI9341	
Interface Type	SPI 4-wires	
Backlight Type	4 White LED	
Touch Panel	RTP Available	

2. Mechanical Drawing

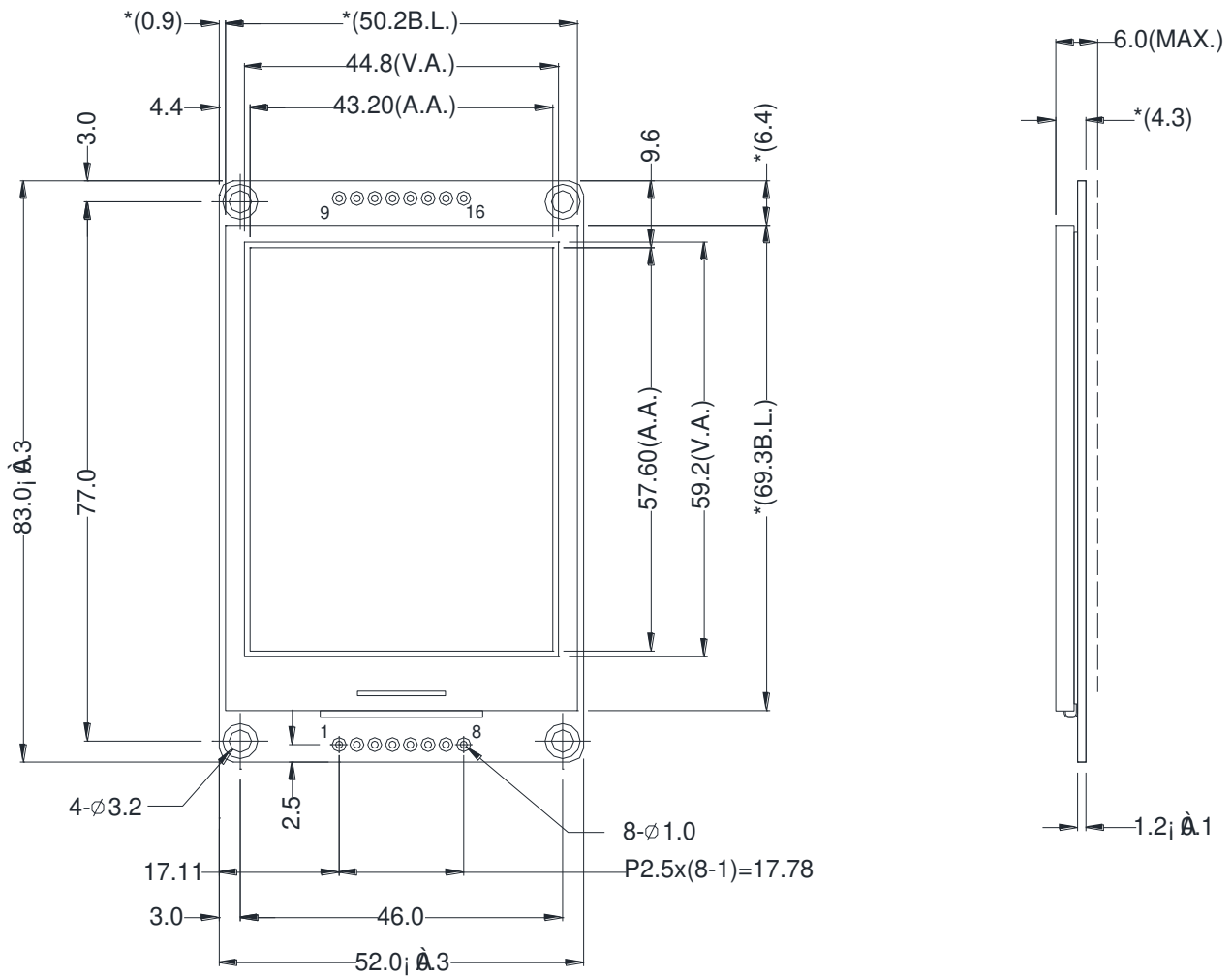

*ILI9341 or equivalent

*() dimension for reference only

3. Block Diagram

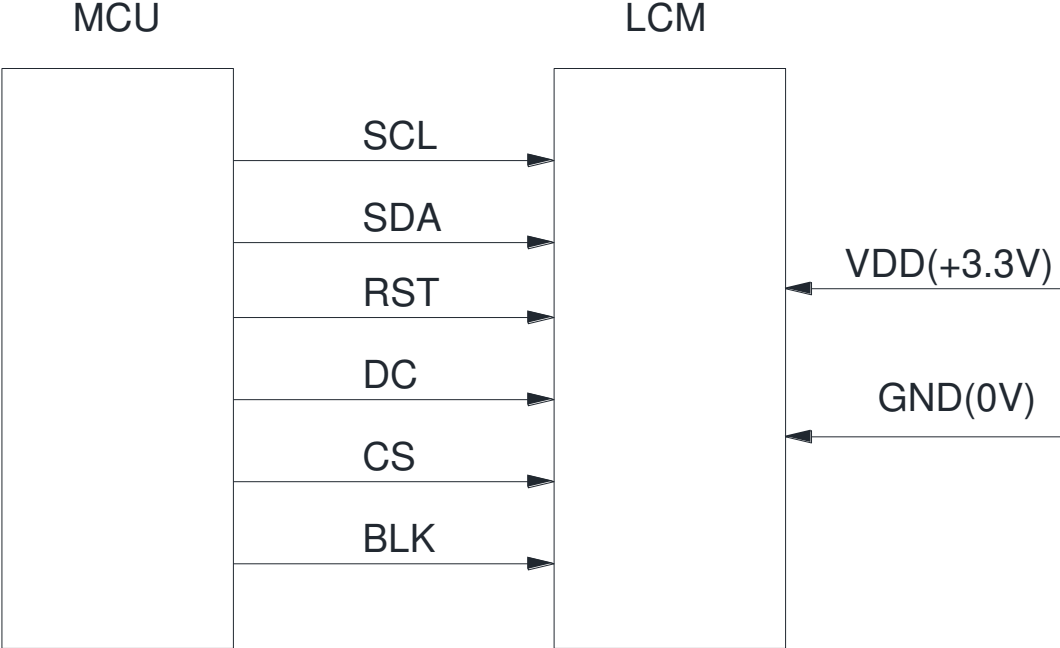

4. Interface Pin Function

Pin No.	Symbol	Level	Description
1	GND	0V	Ground
2	V _{DD}	3.3V	Supply Voltage for logic
3	SCL	H/L	Serial Clock
4	SDA	H/L	Serial Data
5	RST	H/L	Reset, signal is active low
6	DC	H/L	H:Display data or Parameter, L:Command Data
7	CS	H/L	Chip Select, signal is active low
8	BLK	H/L	Backlight control, H:turn on ,L: turn off

5. Absolute Maximum Ratings

Item	Symbol	Min	Max	Unit
Supply Voltage	V _{DD}	-0.3	4.6	V
Input Voltage(logic input)	V _{In}	-0.3	V _{DD} +0.3	V
Operating Temperature	Top	-20	70	°C
Storage Temperature	Tstr	-30	80	°C

Note: The absolute maximum rating values of this product are not allowed to be exceeded at any time. Should a module be used with any of the absolute maximum ratings exceeded, the characteristics of the module may not be recovered, or in an extreme case, the module may be permanently destroyed.

6. Electrical Characteristics

Item	Symbol	Condition	Min	Typ	Max	Unit
Supply Voltage	V _{DD}	—	2.7	3.0	3.3	V
Input Voltage for Logic	V _{io}	-	0	-	3.3	V
Input High Volt.	V _{IH}	—	0.7 V _{DD}	—	V _{DD}	V
Input Low Volt.	V _{IL}	—	V _{SS}	—	0.3 V _{DD}	V

7. Optical Characteristics

Item	Symbol	Condition	Min	Typ	Max	Unit
Luminance	L	—	300	—	—	Cd/m ²
Contrast Ratio	CR	$\theta=0^\circ$	—	500:1	—	—
Response Time	T on	25°C	—	30	-	ms
	T off					
Color Filter Chromaticity	White	W _X	0.255	-	0.330	
		W _Y	0.255	-	0.330	
	Red	R _X				
		R _Y				
	Green	G _X				
		G _Y				
	Blue	B _X				
		B _Y				
Viewing angle	Hor.	Θ_{x-}	CR>10	--	70	--
		Θ_{x+}		--	70	--
	Ver.	Θ_{y+}		--	70	--
		Θ_{y-}		--	45	--
Uniformity	Un	—	80	-	—	%

Note1: Definition of Viewing Angle θ_x and θ_y :

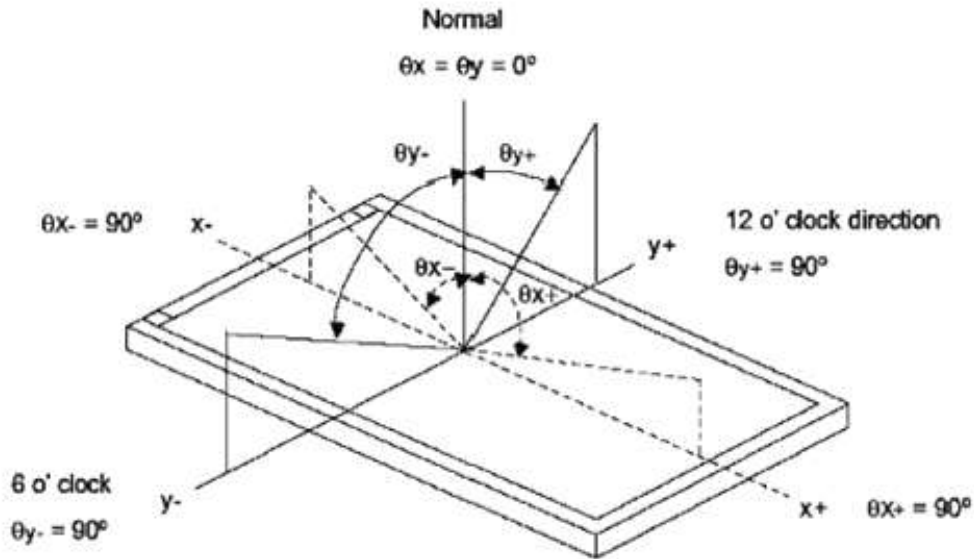

Note 2: Definition of contrast ratio CR:

$$CR = \frac{\text{Luminance of white state}}{\text{Luminance of black state}}$$

Note 3: Definition of Response Time (T_r, T_f):

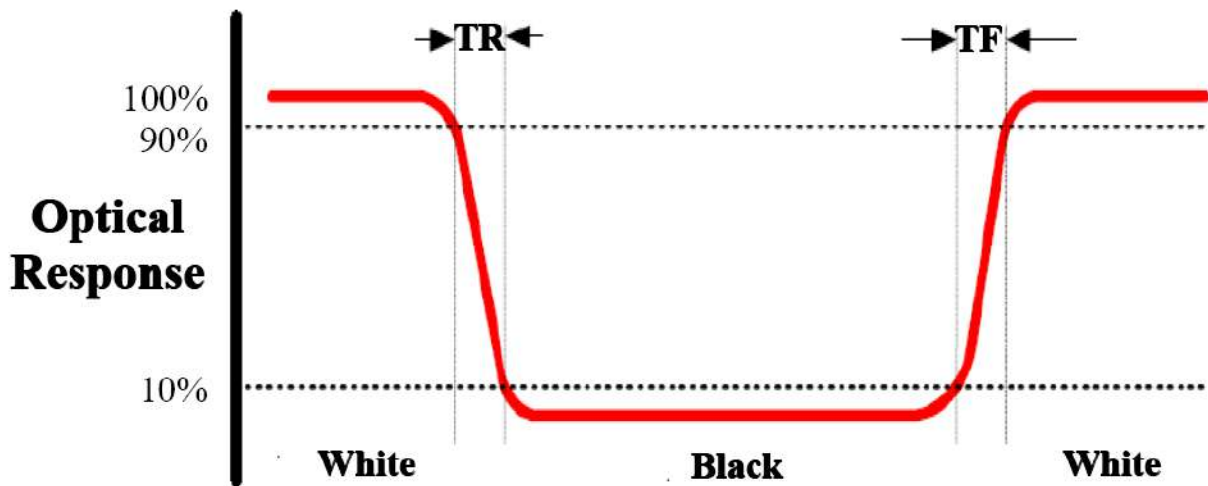

Note 4: Definition of Luminance:

① The Brightness Test Equipment Setup

Field=2°(As measuring "black" image, field=2°is the best testing condition)

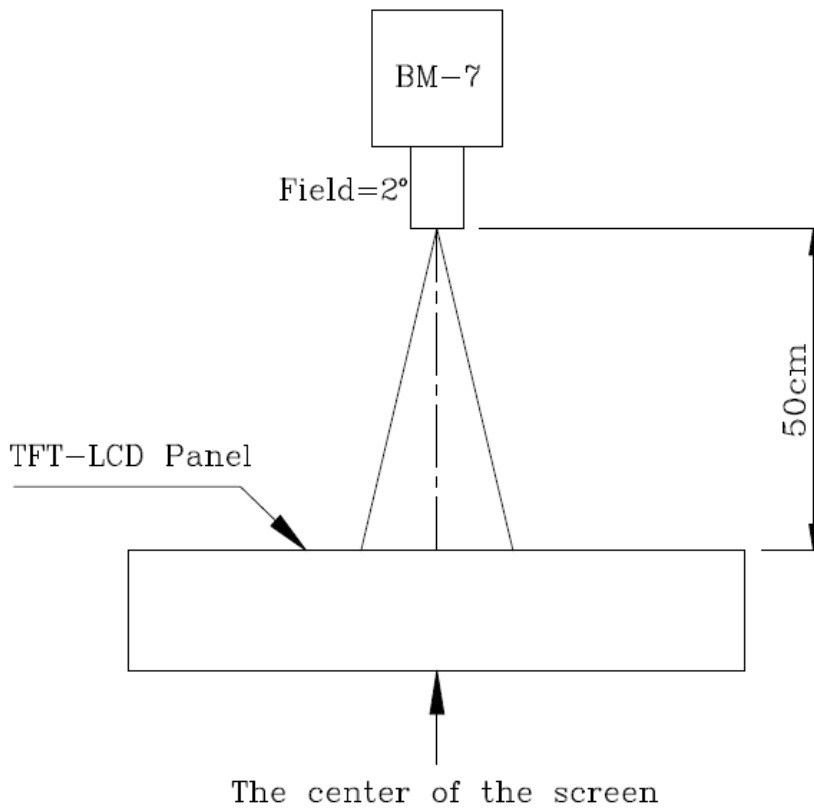

② The Brightness Test Point Setup

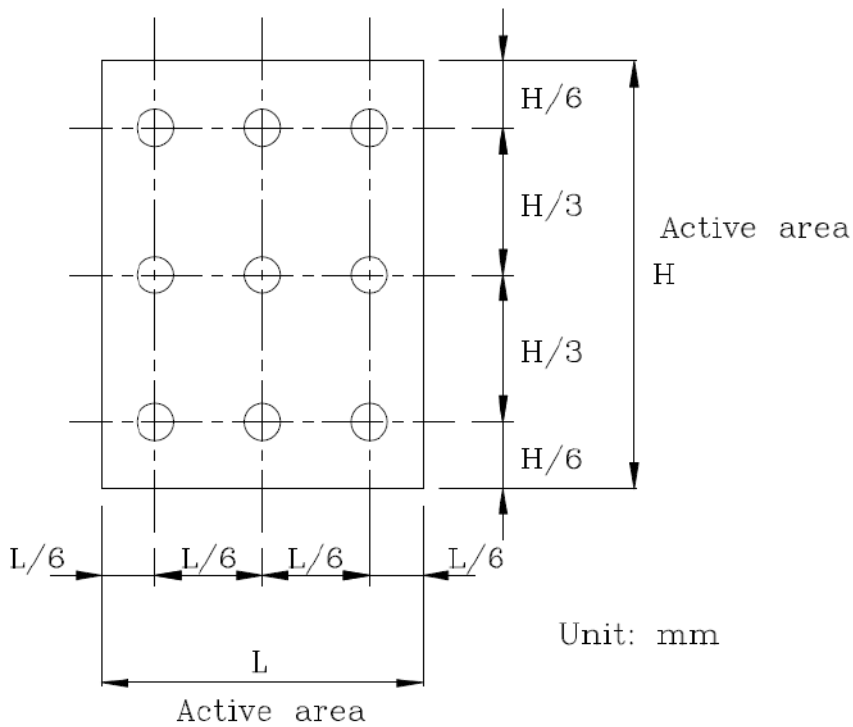

8. Timing Characteristics

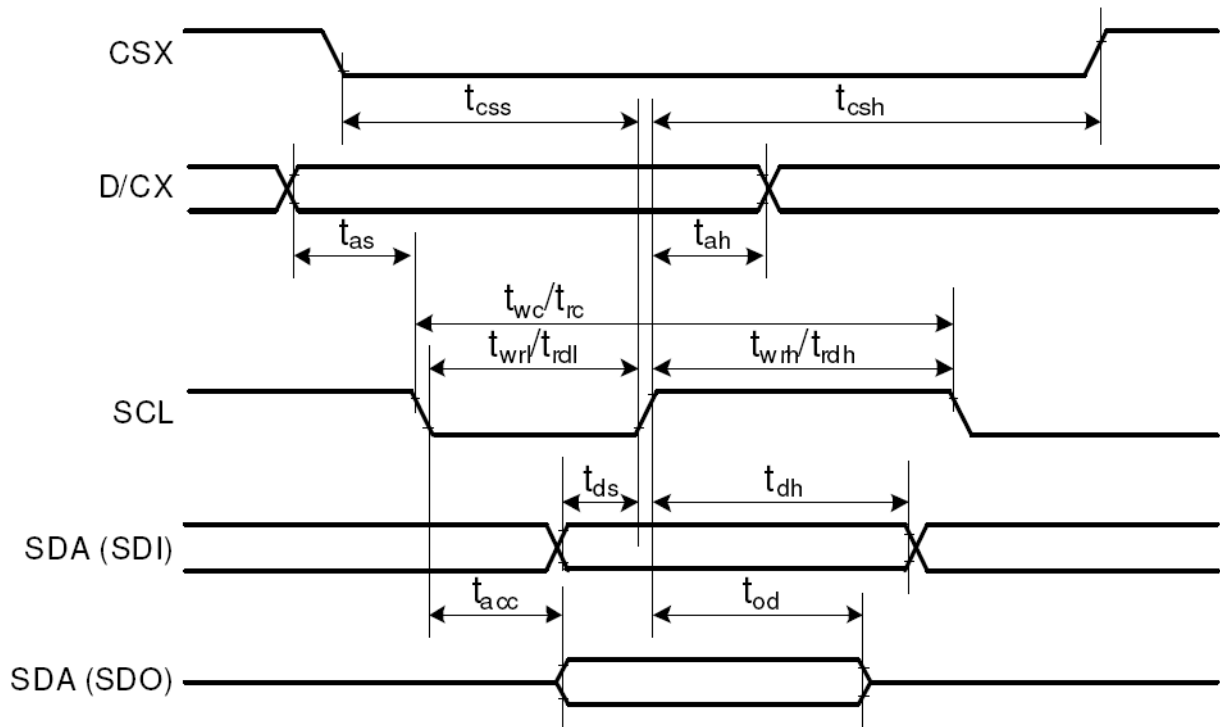

Signal	Symbol	Parameter	min	max	Unit	Description
CSX	t_{css}	Chip select time (Write)	40	-	ns	
	t_{csh}	Chip select hold time (Read)	40	-	ns	
SCL	t_{wc}	Serial clock cycle (Write)	100	-	ns	
	t_{wrh}	SCL "H" pulse width (Write)	40	-	ns	
	t_{wr}	SCL "L" pulse width (Write)	40	-	ns	
	t_{rc}	Serial clock cycle (Read)	150	-	ns	
	t_{rdh}	SCL "H" pulse width (Read)	60	-	ns	
	t_{rdl}	SCL "L" pulse width (Read)	60	-	ns	
D/CX	t_{as}	D/CX setup time	10	-		
	t_{ah}	D/CX hold time (Write / Read)	10	-		
SDA / SDI (Input)	t_{ds}	Data setup time (Write)	30	-	ns	
	t_{dh}	Data hold time (Write)	30	-	ns	
SDA / SDO (Output)	t_{acc}	Access time (Read)	10	-	ns	For maximum $C_L=30\text{pF}$
	t_{od}	Output disable time (Read)	10	50	ns	For minimum $C_L=8\text{pF}$

9. Standard Specification for Reliability

9.1 Standard Specification for Reliability of LCD Module

No	Test Item	Condition	Remarks
1	High Temperature Operation	Ts = +70°C, 96 hours	IEC60068-21:2007 GB2423.2-2008
2	Low Temperature Operation	Ts = -20°C, 96 hours	IEC60068-2-1:2007 GB/2423.1-2008
3	High Temperature Storage	Ta = +80°C, 96 hours	IEC60068-21:2007 GB/2423.2-2008
4	Low Temperature Storage	Ta = -30°C, 96 hours	IEC60068-21:2007 GB/2423.1-2008
5	Storage at High Temperature and Humidity	Ta = +60°C, 90% RH max, 48 hours	IEC60068-2-78 :2001 GB/T2423.3—2006
6	Thermal Shock (nonoperation)	-20°C 30 min~+70°C 30 min, Change time:5min, 10 Cycle	Start with cold temperature, End with high temperature, IEC60068-214:1984, GB/2423.22-2002
7	ESD	C=150pF,R=330 Ω ,5point/panel Air: ± 8Kv,5times; Contact: ± 4Kv,5times (Environment:15°C~35°C, 30%~60%.86Kpa~106Kpa)	IEC61000-42:2001 GB/T17626.2-2006
8	Vibration Test	Frequency range:10~55Hz Stroke:1.5mm Sweep:10Hz~55Hz~10Hz 2 hours for each direction of X.Y.Z (6 hours for total)	IEC60068-2-6:1982 GB/T2423.101995
9	Mechanical Shock (Non Op)	Half Sine Wave60G 6ms, ± X, ± Y, ± Z 3times for each direction	IEC60068-2-27:1987 GB/T2423.5—1995
10	Package Drop Test	Height:80cm, 1corner,3 edges,6 surfaces	IEC60068-2-32:1990 GB/T2423.8—1995

Note1: Ts is the temperature of panel's surface.

Note2: Ta is the ambient temperature of sample.

9.2 Testing Conditions and Inspection Criteria

For the final test, the testing sample must be stored at room temperature for 24 hours. After the tests listed in Table 9.2, standard specifications for reliability will be executed in order to ensure stability.

No.	Item	Test Model	In section Criteria
1	Current Consumption	Refer To Specification	The current consumption should conform to the product specification.
2	Contrast	Refer To Specification	After the tests have been executed, the contrast must be larger than half of its initial value prior to the tests.
3	Appearance	Visual inspection	Defect free.

9.3 MTBF

MTBF	Functions, performance, appearance, etc. shall be free from remarkable deterioration within 50,000 hours under ordinary operating and storage conditions room temperature ($25 \pm 5^{\circ}\text{C}$), normal humidity ($50 \pm 10\%$ RH), and in area not exposed to direct sun light.
------	---

10.Specification of Quality Assurance

This standard of Quality Assurance confirms to the quality of LCD module products supplied by ODNA.

10.1 Quality Test

Before delivering, the supplier should conduct the following tests to confirm the quality of products.

Electrical-Optical Characteristics: According to the individual specification to test the product.

Appearance Characteristics: According to the individual specification to test the product.

Reliability Characteristics: According to the definition of reliability on the specification for testing products.

10.2 Delivery Test

Before delivering, the supplier should conduct the delivery test.

Test method: According to MIL-STD105E.General Inspection Level II take a single
Time.

The defects classify of AQL as following:

Major defect: AQL = 0.65

Minor defect: AQL = 1.5

Total defects: AQL = 1.5

10.3 Non-conforming Analysis & Deal with Manners

10.3.1 Non-conforming Analysis

Purchaser should provide the data detail of non-conforming sample and the non-conforming.

After receiving the data detail from purchaser, the analysis of non-conforming should be finished within two weeks.

If the analysis can't be finished on time, supplier must notice purchaser 3 days in advance.

10.3.2 Disposition of non-conforming

If any product defect be found during assembling, supplier must change the good for every defect after confirmation.

Both supplier and customer should analyze the reason and discuss the disposition of non-conforming when the reason of nonconforming is not sure.

10.4 Agreement items

Both parties should negotiate together when the following problems happen.
There is any problem of standard of quality assurance, and both sides should agree that it must be modified.

There is any argument item which does not record in the standard of quality assurance.

Any other special problem.

10.5 Standard of The Product Appearance Test

10.5.1 Manner of appearance test

The test must be under 20W × 2 or 40W fluorescent light, and the distance of view must be at 30±5cm.

When test the model of transmissive product must add the reflective plate.

The test direction is base on around 10° of vertical line.

Temperature: 25±5°C Humidity: 60±10%RH

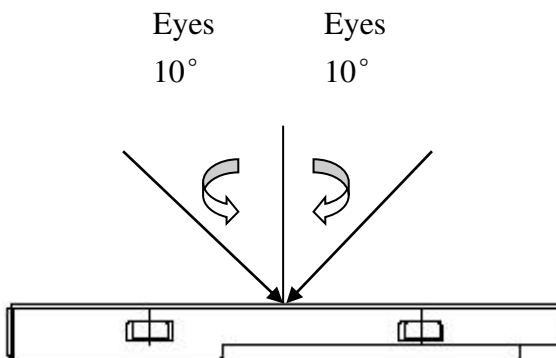

Definition of area:

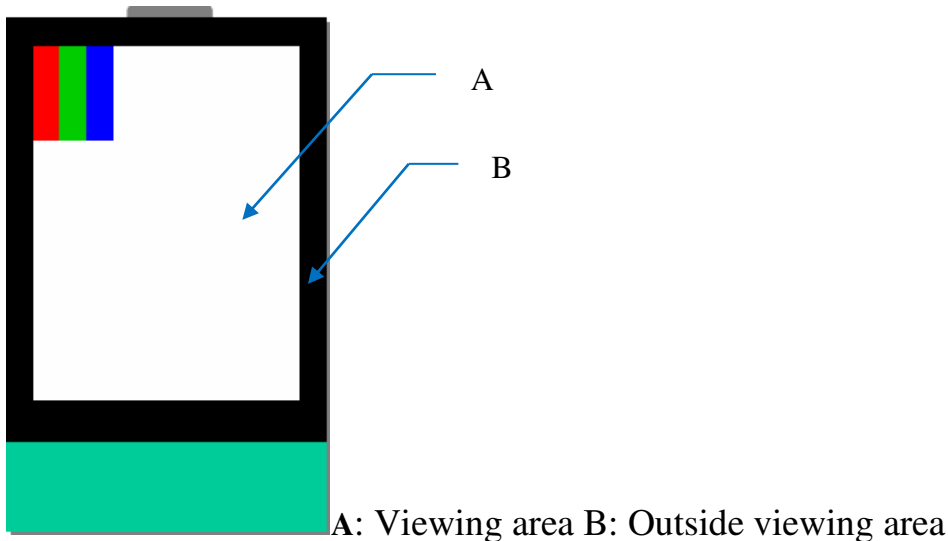

10.5.2 Basic principle

When the standard can not be described, AQL will be applied.

The sample of the lowest acceptable quality level must be negotiated by both supplier and customer when any dispute happened.

New item must be added on time when it is necessary.

10.6 Inspection Specification

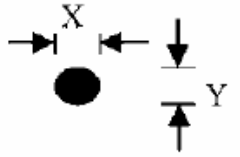
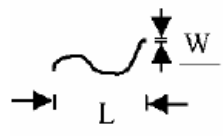
NO.	Item	Criterion	AQL													
1	Electrical Testing	1.1 Missing vertical, horizontal segment, segment contrast defect. 1.2 Missing character, dot or icon. 1.3 Display malfunction. 1.4 No function or no display. 1.5 Current consumption exceeds product specifications. 1.6 LCD viewing angle defect. 1.7 Mixed product types. 1.8 Flicker	0.65													
2	Black or White spots or Bright spots or Color spots on LCD (Display only)	2.1 White and black or color spots on display $\cong 0.25\text{mm}$, no more than Five spots. 2.2 Densely spaced: No more than three spots within 3mm.	1.5													
3	LCD and Touch Panel black spots, white spots, contamination (non - display)	3.1 Round type: As following drawing $\Phi = (X+Y) / 2$ <div style="text-align: center;">  </div> <table border="1" style="margin-left: auto; margin-right: auto;"> <thead> <tr> <th>Size(mm)</th> <th>Acceptable Q'ty</th> </tr> </thead> <tbody> <tr> <td>$\Phi \cong 0.10$</td> <td>Accept no dense</td> </tr> <tr> <td>$0.10 < \Phi \cong 0.20$</td> <td>2</td> </tr> <tr> <td>$0.20 < \Phi \cong 0.25$</td> <td>2</td> </tr> <tr> <td>$0.25 < \Phi \cong 0.30$</td> <td>1</td> </tr> <tr> <td>$0.30 < \Phi$</td> <td>0</td> </tr> </tbody> </table> <p>* Densely spaced: No more than two spots within 3mm.</p>	Size(mm)	Acceptable Q'ty	$\Phi \cong 0.10$	Accept no dense	$0.10 < \Phi \cong 0.20$	2	$0.20 < \Phi \cong 0.25$	2	$0.25 < \Phi \cong 0.30$	1	$0.30 < \Phi$	0	1.5	
		Size(mm)	Acceptable Q'ty													
$\Phi \cong 0.10$	Accept no dense															
$0.10 < \Phi \cong 0.20$	2															
$0.20 < \Phi \cong 0.25$	2															
$0.25 < \Phi \cong 0.30$	1															
$0.30 < \Phi$	0															
3.2 Line type: (As following drawing) <div style="text-align: center;">  </div> <table border="1" style="margin-left: auto; margin-right: auto;"> <thead> <tr> <th>Length(mm)</th> <th>Width(mm)</th> <th>Acceptable Q'ty</th> </tr> </thead> <tbody> <tr> <td>---</td> <td>$W \cong 0.02$</td> <td>Accept no dense</td> </tr> <tr> <td>$L \cong 3.0$</td> <td>$0.02 < W \cong 0.05$</td> <td>2</td> </tr> <tr> <td>$L \cong 2.5$</td> <td>$0.03 < W \cong 0.08$</td> <td>2</td> </tr> <tr> <td>---</td> <td>$0.08 < W$</td> <td>Rejection</td> </tr> </tbody> </table> <p>* Densely spaced: No more than two lines within 3mm.</p>	Length(mm)	Width(mm)	Acceptable Q'ty	---	$W \cong 0.02$	Accept no dense	$L \cong 3.0$	$0.02 < W \cong 0.05$	2	$L \cong 2.5$	$0.03 < W \cong 0.08$	2	---	$0.08 < W$	Rejection	1.5
Length(mm)	Width(mm)	Acceptable Q'ty														
---	$W \cong 0.02$	Accept no dense														
$L \cong 3.0$	$0.02 < W \cong 0.05$	2														
$L \cong 2.5$	$0.03 < W \cong 0.08$	2														
---	$0.08 < W$	Rejection														

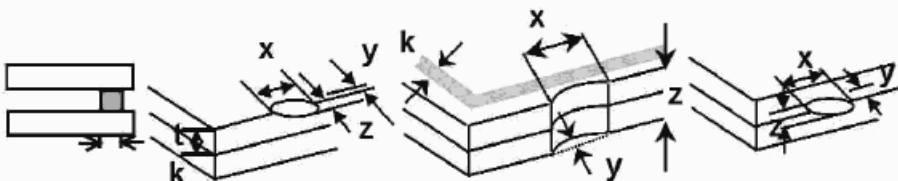
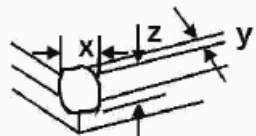
NO.	Item	Criterion			AQL	
4	Polarizer bubbles	If bubbles are visible, judge using black spot specifications, not easy to find, must check in specify direction	Size Φ (mm)	Acceptable Q'ty	1.5	
			$\Phi \leq 0.30$	Accept no dense		
			$0.30 < \Phi \leq 0.50$	0		
			$0.50 < \Phi \leq 1.00$	0		
			$1.00 < \Phi$	0		
			Total Q' ty	0		
5	Scratches	Follow NO.3 -2 Line Type.				
6	Chipped glass	Symbols: x: Chip length y: Chip width z: Chip thickness k: Seal width t: Glass thickness a: LCD side length L: Electrode pad length 6.1 General glass chip: 6.1.1 Chip on panel surface and crack between panels:			1.5	
			z: Chip thickness	y: Chip width		x: Chip length
			$Z \leq 1/2t$	Not over viewing area		$x \leq 2MM$
			$1/2t < z \leq 2t$	Not exceed 1/3k		$x \leq 2MM$
			⊙ Unit: mm ⊙ If there are 2 or more chips, x is the total length of each chip			
			6.1.2 Corner crack:			
						
z: Chip thickness	y: Chip width	x: Chip length				
$Z \leq 1/2t$	Not over viewing area	$x \leq 2MM$				
$1/2t < z \leq 2t$	Not exceed 1/3k	$x \leq 2MM$				
⊙ Unit: mm ⊙ If there are 2 or more chips, x is the total length of each chip						

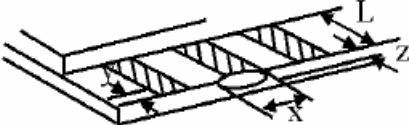
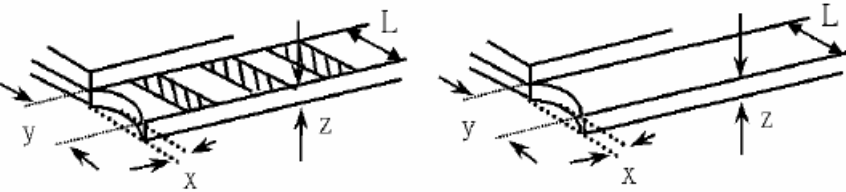
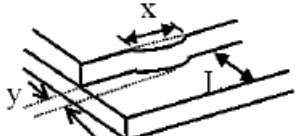
NO.	Item	Criterion	AQL																
7	Glass crack	<p>Symbols: x: Chip length y: Chip width z: Chip thickness k: Seal width t: Glass thickness a: LCD side length L: Electrode pad length</p> <p>7.2 Protrusion over terminal: 7.2.1 Chip on electrode pad:</p>  <table border="1" data-bbox="421 521 1332 602"> <tr> <td>y: Chip width</td> <td>x: Chip length</td> <td>z: Chip thickness</td> </tr> <tr> <td>$y \cong 0.5\text{mm}$</td> <td>$x \cong 2\text{MM}$</td> <td>$0 < z \cong t$</td> </tr> </table> <p>7.2.2 Non-conductive portion:</p>  <table border="1" data-bbox="421 880 1332 960"> <tr> <td>y: Chip width</td> <td>x: Chip length</td> <td>z: Chip thickness</td> </tr> <tr> <td>$y \cong L$</td> <td>$x \cong 2\text{MM}$</td> <td>$0 < z \cong t$</td> </tr> </table> <p>⊙ If there chipped area touches the ITO terminal, over 2/3 of the ITO must remain and be inspected according to electrode terminal specifications. ⊙ If the product will be heat sealed by the customer, the alignment mark must not be damaged.</p> <p>7.2.3 Substrate protuberance and internal crack</p>  <table border="1" data-bbox="778 1234 1141 1314"> <tr> <td>y: width</td> <td>x: length</td> </tr> <tr> <td>$y \cong 1/3L$</td> <td>$X \cong 2\text{MM}$</td> </tr> </table>	y: Chip width	x: Chip length	z: Chip thickness	$y \cong 0.5\text{mm}$	$x \cong 2\text{MM}$	$0 < z \cong t$	y: Chip width	x: Chip length	z: Chip thickness	$y \cong L$	$x \cong 2\text{MM}$	$0 < z \cong t$	y: width	x: length	$y \cong 1/3L$	$X \cong 2\text{MM}$	1.5
y: Chip width	x: Chip length	z: Chip thickness																	
$y \cong 0.5\text{mm}$	$x \cong 2\text{MM}$	$0 < z \cong t$																	
y: Chip width	x: Chip length	z: Chip thickness																	
$y \cong L$	$x \cong 2\text{MM}$	$0 < z \cong t$																	
y: width	x: length																		
$y \cong 1/3L$	$X \cong 2\text{MM}$																		

NO.	Item	Criterion	AQL
8	Cracked glass	No crack is allowed.	1.5
9	Backlight elements	9.1 Illumination source flickers when lit. 9.2 Spots or scratches that appear when lit must be judged. Using LCD spot, lines and contamination standards. 9.3 Backlight doesn't light or color is wrong.	1.5 1.5 0.65
10	Bezel	No scratches with $W > 0.1$ and $Length > 2.5mm$.	1.5
11	PCB、COB	11.1 COB seal may not have pinholes larger than 0.2mm or contamination. 11.2 COB seal surface may not have pinholes through to the IC. 11.3 The height of the COB should not exceed the height indicated in the assembly diagram. 11.4 There may not be more than 2mm of sealant outside the seal area on PCB. And there should be no more than three places. 11.5 Parts on PCB must be the same as on the production characteristic chart, There should be no wrong parts, missing parts or excess parts. 11.6 The jumper on the PCB should conform to the product characteristic chart.	1.5 1.5 1.5 1.5 0.65 0.65
12	FPC	FPC damage per IPC guidelines.(IPC-A-610) Nicks or damage along the edges of the flexible printed circuitry and cutouts, providing the penetration does not exceed 50% of the distance from the edge to the nearest conductor to 2.5mm[0.1in], Whichever is less.	1.5
13	Soldering	13.1 No cold solder joints, missing solder connections, oxidation or icicle. 13.2 No short circuits in components on PCB or FPC. 13.3 Soldering per IPC guidelines.(IPC-A-610)	1.5 1.5 0.65

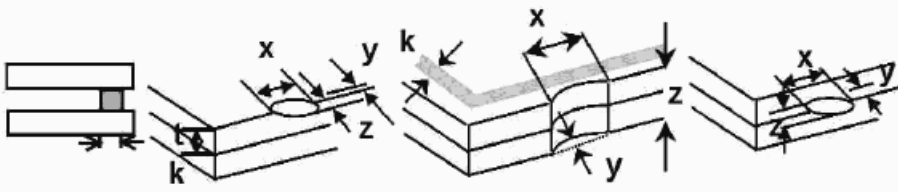
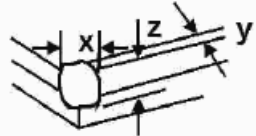
NO.	Item	Criterion	AQL												
14	Touch Panel Chipped glass	<p>Symbols: x: Chip length y: Chip width z: Chip thickness k: Seal width t: Touch Panel Total thickness a: LCD side length L: Electrode pad length</p> <p>14.1 General glass chip: 14.1.1 Chip on panel surface and crack between panels:</p>  <table border="1" data-bbox="422 571 1324 694"> <tr> <td>z: Chip thickness</td> <td>y: Chip width</td> <td>x: Chip length</td> </tr> <tr> <td>$Z \cong t$</td> <td>$\cong 1/2 k$ and not over viewing area</td> <td>$x \cong 2MM$</td> </tr> </table> <p>⊙ Unit: mm ⊙ If there are 2 or more chips, x is the total length of each chip</p> <p>14.1.2 Corner crack:</p>  <table border="1" data-bbox="422 952 1324 1075"> <tr> <td>z: Chip thickness</td> <td>y: Chip width</td> <td>x: Chip length</td> </tr> <tr> <td>$Z \cong t$</td> <td>$\cong 1/2 k$ and not over viewing area</td> <td>$x \cong 2MM$</td> </tr> </table> <p>⊙ Unit: mm ⊙ If there are 2 or more chips, x is the total length of each chip</p>	z: Chip thickness	y: Chip width	x: Chip length	$Z \cong t$	$\cong 1/2 k$ and not over viewing area	$x \cong 2MM$	z: Chip thickness	y: Chip width	x: Chip length	$Z \cong t$	$\cong 1/2 k$ and not over viewing area	$x \cong 2MM$	1.5
z: Chip thickness	y: Chip width	x: Chip length													
$Z \cong t$	$\cong 1/2 k$ and not over viewing area	$x \cong 2MM$													
z: Chip thickness	y: Chip width	x: Chip length													
$Z \cong t$	$\cong 1/2 k$ and not over viewing area	$x \cong 2MM$													

NO.	Item	Criterion	AQL										
15	Touch Panel(Fish eye、dent and bubble on film)	<table border="1" data-bbox="440 159 1334 367"> <thead> <tr> <th data-bbox="440 159 884 197">SIZE(mm)</th> <th data-bbox="884 159 1334 197">Acceptable Q' ty</th> </tr> </thead> <tbody> <tr> <td data-bbox="440 197 884 235">$\Phi \leq 0.2$</td> <td data-bbox="884 197 1334 235">Accept no dense</td> </tr> <tr> <td data-bbox="440 235 884 273">$0.2 < D \leq 0.4$</td> <td data-bbox="884 235 1334 273">5</td> </tr> <tr> <td data-bbox="440 273 884 311">$0.4 < D \leq 0.5$</td> <td data-bbox="884 273 1334 311"></td> </tr> <tr> <td data-bbox="440 311 884 367">$0.5 < D$</td> <td data-bbox="884 311 1334 367">0</td> </tr> </tbody> </table> <div data-bbox="459 443 1142 864" style="text-align: center;"> </div>	SIZE(mm)	Acceptable Q' ty	$\Phi \leq 0.2$	Accept no dense	$0.2 < D \leq 0.4$	5	$0.4 < D \leq 0.5$		$0.5 < D$	0	1.5
SIZE(mm)	Acceptable Q' ty												
$\Phi \leq 0.2$	Accept no dense												
$0.2 < D \leq 0.4$	5												
$0.4 < D \leq 0.5$													
$0.5 < D$	0												
16	Touch Panel Newton ring	Newton ring dimension \cong 1/2 touch panel area and not affect font and line distortion(\cong 2.5%) , it is acceptable.	1.5										
17	Touch Panel Linearity	Less than 1.5% is acceptable.	1.5										
18	LCD Ripple	Touch the touch panel , can not see the LCD ripple. Pen: R 1.0mm silicon rubber. Operation Force: 80g	1.5										
19	General appearance	19.1 Pin type must match type in specification sheet. 19.2 LCD pin loose or missing pins. 19.3 Product packaging must the same as specified on packaging specification sheet. 19.4 Product dimension and structure must conform to product specification sheet.	0.65 0.65 0.65 0.65										

11. Handling Precaution

11.1 Handling of LCM

Avoid external shock.

Don't apply excessive force on the surface.

Liquid in LCD is hazardous substance, do not lick or swallow. When the liquid is attaching to your hand, skin, cloth, etc., wash it thoroughly and immediately.

Don't operate it above the absolute maximum rating.

Don't disassemble the LCM.

The operators should wear protections whenever he/she comes into contact with the module. Never touch any of the conductive parts such as the LSI pads, the copper leads on the PCB and the interface terminals with any parts of the human body.

The modules should be kept in antistatic bags or other containers resistant to static for storage.

The module is coated with a film to protect the display surface, be careful when peeling off this protective film since static electricity may be generated.

11.2 Storage

Store it in an ambient temperature of $25\pm 10^{\circ}\text{C}$, and in a relative

humidity of $50\pm 10\% \text{RH}$. Don't expose to sunlight or fluorescent light.

Store it in a clean environment, free from dust, active gas, and solvent.

Store it in anti-static electricity container.

Store it without any physical load.

11.3 Soldering

Use only soldering irons with proper grounding and no leakage.

Iron: no higher than $280\pm 10^{\circ}\text{C}$ and less than 3 sec during hand soldering.

Rewiring: no more than 2 times.

12. Packing Method

TBD