

CM1282-01D1

1-Channel Ultra-Low Capacitance ESD Protection Device

Product Description

The CM1282-01D1 is an ultra-low capacitance, 1-channel ESD protection device. The CM1282-01D1 is fully compliant with IEC 61000-4-2 and is also RoHS-compliant.

Features

- 1 Channel ESD Protection
- Provides In-System ESD Protection to IEC61000-4-2 Level 4
 - ± 8 kV Contact Discharge
- Back-to-Back Diode (I/O-to-I/O Configuration)
- Compact DSN2 (1 mm x 0.6 mm x 0.5 mm) Package Saves Board Space and Facilitates Layout in Space-Critical Applications
- These Devices are Pb-Free and are RoHS Compliant

Applications

ESD Protection for Static-Sensitive Electronic Equipment such as:

- Wireless Handsets
- Handheld PCs/PDAs
- MP3 Players
- Digital Camcorders
- Notebooks
- Desktop PCs



ON Semiconductor®

<http://onsemi.com>



DSN2
D1 SUFFIX
CASE 152AE

ELECTRICAL SCHEMATIC

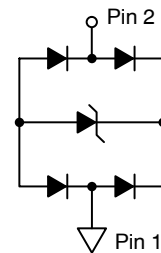

MARKING DIAGRAM

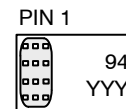

94 = Specific Device Code
YYY = Year Code

ORDERING INFORMATION

Device	Package	Shipping†
CM1282-01D1	DSN2 (Pb-Free)	5000/Tape & Reel

†For information on tape and reel specifications, including part orientation and tape sizes, please refer to our Tape and Reel Packaging Specification Brochure, BRD8011/D.

CM1282-01D1

PACKAGE / PINOUT DIAGRAM

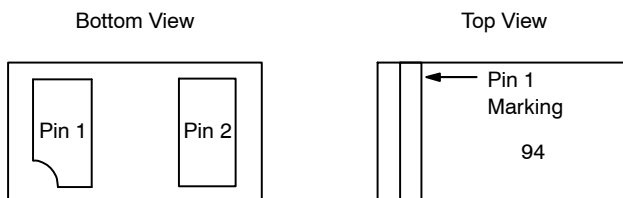

Table 1. PIN DESCRIPTIONS

1-Channel DSN2 Package			
Pin	Name	Type	Description
1	V _N	GND	Ground
2	CH	I/O	ESD Channel

SPECIFICATIONS

Table 2. ABSOLUTE MAXIMUM RATINGS

Parameter	Rating	Units
Storage Temperature Range	-65 to +150	°C
Package Power Dissipation	450	mW

Stresses exceeding Maximum Ratings may damage the device. Maximum Ratings are stress ratings only. Functional operation above the Recommended Operating Conditions is not implied. Extended exposure to stresses above the Recommended Operating Conditions may affect device reliability.

Table 3. STANDARD OPERATING CONDITIONS

Parameter	Rating	Units
Operating Temperature	-40 to +85	°C

Table 4. ELECTRICAL OPERATING CHARACTERISTICS (Note 1)

Symbol	Parameter	Conditions	Min	Typ	Max	Units
V _{BR}	Reverse Breakdown Voltage	I _{IN} = ±10 mA	±7.5	±9.0	±11.0	V
I _{LEAK}	Channel Leakage Current	V _{IN} = ±5 V		0.1	1.0	μA
C _{IN}	Channel Input Capacitance	At 1 MHz, V _{IN} = 0 V		0.5	0.6	pF
V _{ESD}	ESD Protection (Peak Discharge Voltage at any Channel Input, in System): Contact Discharge per IEC 61000-4-2 Standard	(Note 2)	8			kV
V _{CL}	Channel Clamp Voltage	I _{PP} = ±1 A, t _P = 8/20 μs		11		V
R _{DYN}	Dynamic Resistance	I _{PP} = ±1 A, t _P = 8/20 μs		1.2		Ω

- All parameters specified at T_A = 25°C unless otherwise noted.
- Standard IEC 61000-4-2 with C_{Discharge} = 150 pF, R_{Discharge} = 330 Ω

CM1282-01D1

PACKAGE DIMENSIONS

DSN2, 1.0x0.6, 0.65P, (0402)
CASE 152AE-01
ISSUE O

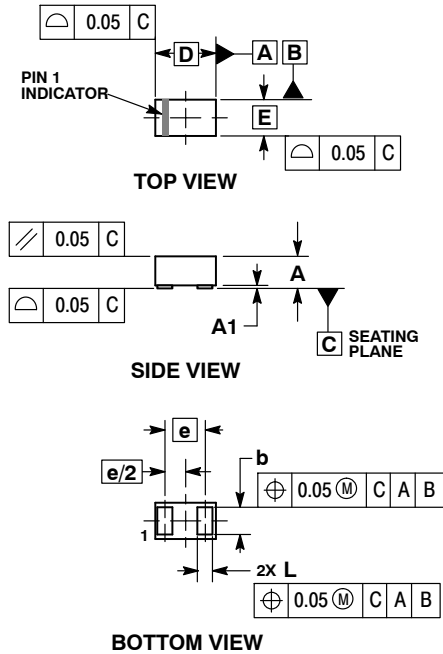

- NOTES:
1. DIMENSIONING AND TOLERANCING PER ASME Y14.5M, 1994.
 2. CONTROLLING DIMENSION: MILLIMETERS.

MILLIMETERS		
DIM	MIN	MAX
A	0.25	0.31
A1	---	0.05
b	0.45	0.55
D	1.00 BSC	
E	0.60 BSC	
e	0.65 BSC	
L	0.20	0.30

RECOMMENDED SOLDER FOOTPRINT*

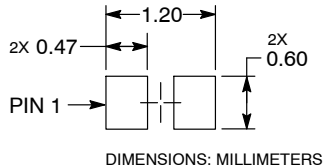

See Application Note AND8398/D for more mounting details

*For additional information on our Pb-Free strategy and soldering details, please download the ON Semiconductor Soldering and Mounting Techniques Reference Manual, SOLDERRM/D.

CATHODE BAND MONTH CODING

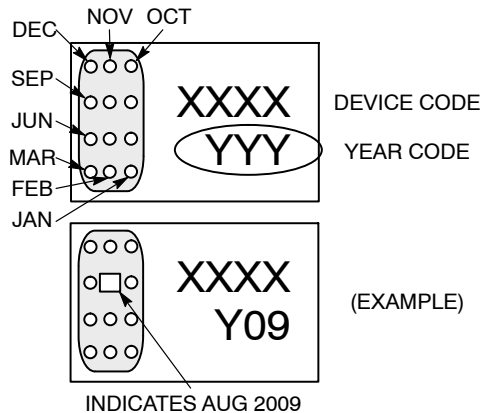

ON Semiconductor and are registered trademarks of Semiconductor Components Industries, LLC (SCILLC). SCILLC reserves the right to make changes without further notice to any products herein. SCILLC makes no warranty, representation or guarantee regarding the suitability of its products for any particular purpose, nor does SCILLC assume any liability arising out of the application or use of any product or circuit, and specifically disclaims any and all liability, including without limitation special, consequential or incidental damages. "Typical" parameters which may be provided in SCILLC data sheets and/or specifications can and do vary in different applications and actual performance may vary over time. All operating parameters, including "Typicals" must be validated for each customer application by customer's technical experts. SCILLC does not convey any license under its patent rights nor the rights of others. SCILLC products are not designed, intended, or authorized for use as components in systems intended for surgical implant into the body, or other applications intended to support or sustain life, or for any other application in which the failure of the SCILLC product could create a situation where personal injury or death may occur. Should Buyer purchase or use SCILLC products for any such unintended or unauthorized application, Buyer shall indemnify and hold SCILLC and its officers, employees, subsidiaries, affiliates, and distributors harmless against all claims, costs, damages, and expenses, and reasonable attorney fees arising out of, directly or indirectly, any claim of personal injury or death associated with such unintended or unauthorized use, even if such claim alleges that SCILLC was negligent regarding the design or manufacture of the part. SCILLC is an Equal Opportunity/Affirmative Action Employer. This literature is subject to all applicable copyright laws and is not for resale in any manner.

PUBLICATION ORDERING INFORMATION

LITERATURE FULFILLMENT:
Literature Distribution Center for ON Semiconductor
P.O. Box 5163, Denver, Colorado 80217 USA
Phone: 303-675-2175 or 800-344-3860 Toll Free USA/Canada
Fax: 303-675-2176 or 800-344-3867 Toll Free USA/Canada
Email: orderlit@onsemi.com

N. American Technical Support: 800-282-9855 Toll Free
USA/Canada
Europe, Middle East and Africa Technical Support:
Phone: 421 33 790 2910
Japan Customer Focus Center
Phone: 81-3-5773-3850

ON Semiconductor Website: www.onsemi.com
Order Literature: <http://www.onsemi.com/orderlit>
For additional information, please contact your local Sales Representative