

LT3001 Micropower No-Opto isolated Flyback Converter with 65V/1.2A Switch

DESCRIPTION

Demonstration circuit 3006A is a compact no-opto isolated flyback converter featuring the [LT[®]3001](#). The DC3006A outputs 12V, and maintains tight regulation with as load current from 1.5mA up to 300mA over an input voltage from 4V to 32V. The output current capability increases with the input voltage, as shown in the Performance Summary table.

Transformer leakage inductance causes a voltage spike on the primary side after the power switch turns off. The leakage inductance spike is limited within the MOSFET's voltage rating of 65V with an RC snubber and a TVS clamp which damp the ringing and clamp the MOSFET drain voltage to a safe level.

The Performance Summary table summarizes the performance of the demo board at room temperature. The demo circuit can be easily modified for different applications with some pre-designed transformers.

The LT3001 datasheet gives a complete description of the part, operation and application information. The datasheet must be read in conjunction with this quick start guide for demo circuit 3006A.

[Design files for this circuit board are available.](#)

All registered trademarks and trademarks are the property of their respective owners.

PERFORMANCE SUMMARY Specifications are at T_A = 25°C

PARAMETER	CONDITIONS	MIN	TYP	MAX	UNITS
Input Voltage		4	12	32	V
Output Voltage	I _{OUT(MIN)} = 1.5mA	11.4	12	12.6	V
Maximum Output Current	V _{IN} = 5V	0.1			A
	V _{IN} = 12V	0.2			A
	V _{IN} = 24V	0.3			A
Output Voltage Ripple (Peak to Peak)	V _{IN} = 12V, I _{OUT} = 0.2A		100		mV

QUICK START PROCEDURE

Demonstration circuit 3006A is easy to set up to evaluate the performance of the LT3001. Refer to Figure 1 for proper measurement equipment setup and follow the procedure below:

1. With power off, connect the input power supply to the board through V_{IN} (E1) and GND (E2) terminals. Connect the load to the terminals V_{OUT}^+ (E3) and V_{OUT}^- (E4) on the board.
2. Turn on the power at the input. Increase V_{IN} slowly to 4V.

NOTE: Make sure that the input voltage is always within spec. To operate the board with higher input/output voltage, input capacitor, output capacitor and output diode with higher voltage ratings might be needed.

3. Check for the proper output voltages. The output should be regulated at 12V ($\pm 5\%$).

NOTE: The LT3001 requires very small minimum load to maintain a good output voltage regulation. A zener diode is placed on the output to clamp the voltage to 13V. This zener can be replaced with 8k Ω resistor at the tradeoff of slightly lower efficiency.

4. Once the proper output voltage is established, adjust the input voltage and load current within the operating range and observe the output voltage regulation, ripple voltage, efficiency and other parameters.

NOTE: When measuring the input or output voltage ripples, care must be taken to avoid a long ground lead on the oscilloscope probe. Measure the input or output voltage ripple by touching the probe tip directly across the V_{IN} (E1) and GND (E2), or V_{OUT}^+ (E3) and V_{OUT}^- (E4) terminals. See Figure 2 for proper scope probe technique.

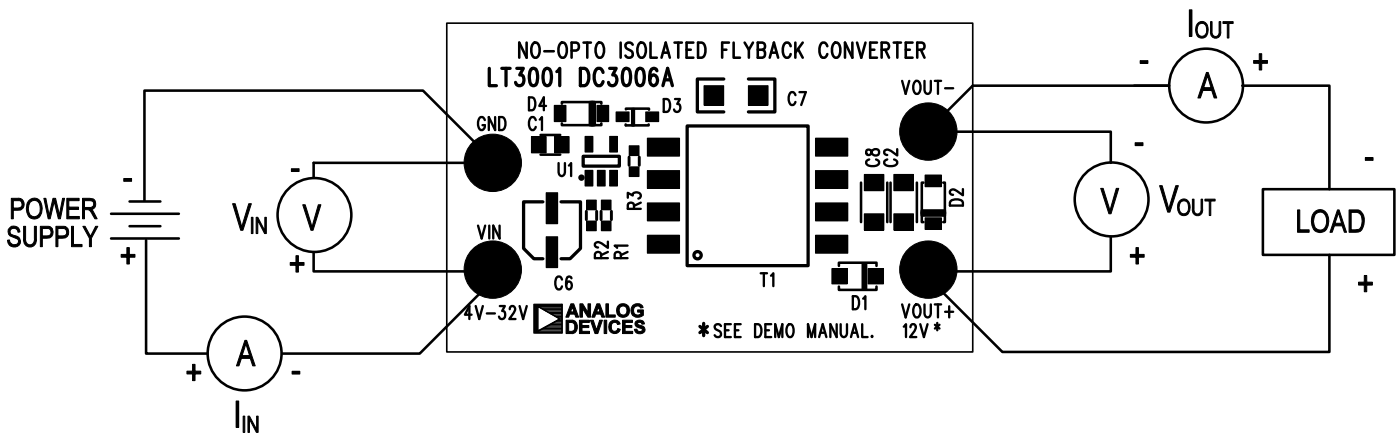

Figure 1. Proper Measurement Equipment Setup

QUICK START PROCEDURE

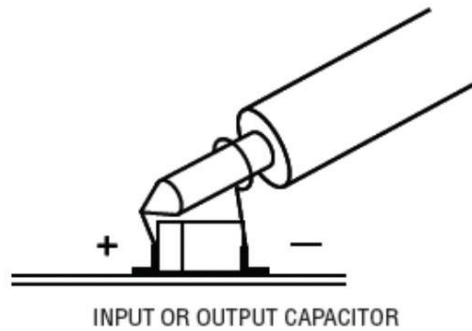

Figure 2. Proper Scope Probe Placement for Measuring Input or Output Ripple

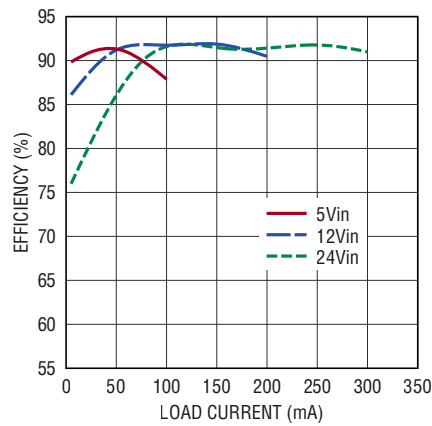

Figure 3. Typical Efficiency Curves

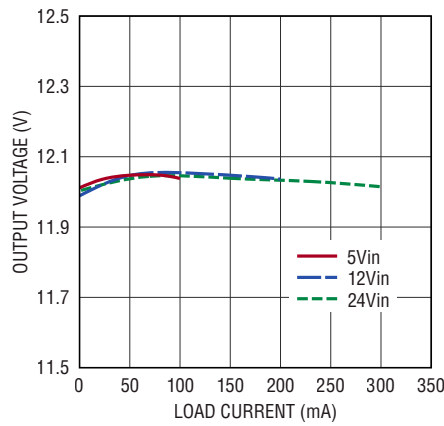

Figure 4. Regulation Curves

DEMO MANUAL DC3006A

PARTS LIST

ITEM	QTY	REFERENCE	PART DESCRIPTION	MANUFACTURER/PART NUMBER
Required Circuit Components				
1	1	C1	CAP, 4.7uF, X5R, 50V, 10%, 0805	MURATA, GRM21BR61H475KE51L
2	2	C2, C8	CAP, 22uF, X5R, 25V, 10%, 1206	AVX, 12063D226KAT2A
3	1	C6	CAP, 10uF, ALUM ELECT, 50V, 20%, RADIAL, AEC-Q200	PANASONIC, EEEFTH100UAR
4	1	C7	CAP, 3300pF, X7R, 630V, 10%, 1206	KEMET, C1206C332KBRAC7800
5	1	D1	DIODE, SCHOTTKY RECT., 2A, 60V, CFP3 (SOD-123W), AEC-Q101	NEXPERIA, PMEG6020ER, 115
6	1	D2	DIODE, ZENER, 13V, 5%, 500mW, SOD-123	CENTRAL SEMI., CMHZ4107 TR PBFREE
7	1	D3	DIODE, GEN PURPOSE, 75V, 150mA, SOD-323	MICRO COMMERCIAL CO., 1N4148WX-TP
8	1	D4	DIODE, ZENER, 24V, 500mW, SOD-123	ON SEMICONDUCTOR, MMSZ5252BT1G
9	1	R1	RES., 0 OHM, 1/10W, 0603, AEC-Q200	VISHAY, CRCW06030000Z0EA
10	1	R3	RES., 118k OHMS, 1%, 1/10W, 0603, AEC-Q200	VISHAY, CRCW0603118KFKEA
11	1	T1	TRANSFORMER, 1:1, Np:18-42Vin, Ns:5V with 0.55A, 15.5x12.5mm SMD, CEP1110 CUSTOM	SUMIDA, 12387-T041 (CEP1110)
12	1	U1	IC, FLYBACK CONVERTER, TSOT-23	ANALOG DEVICES, LT3001ES5#TRPBF
Additional Demo Board Circuit Components				
1	0	R2	RES., OPTION, 0603	
Hardware: For Demo Board Only				
1	4	E1-E4	TEST POINT, TURRET, 0.094" MTG. HOLE, PCB 0.062" THK	MILL-MAX, 2501-2-00-80-00-00-07-0

SCHEMATIC DIAGRAM

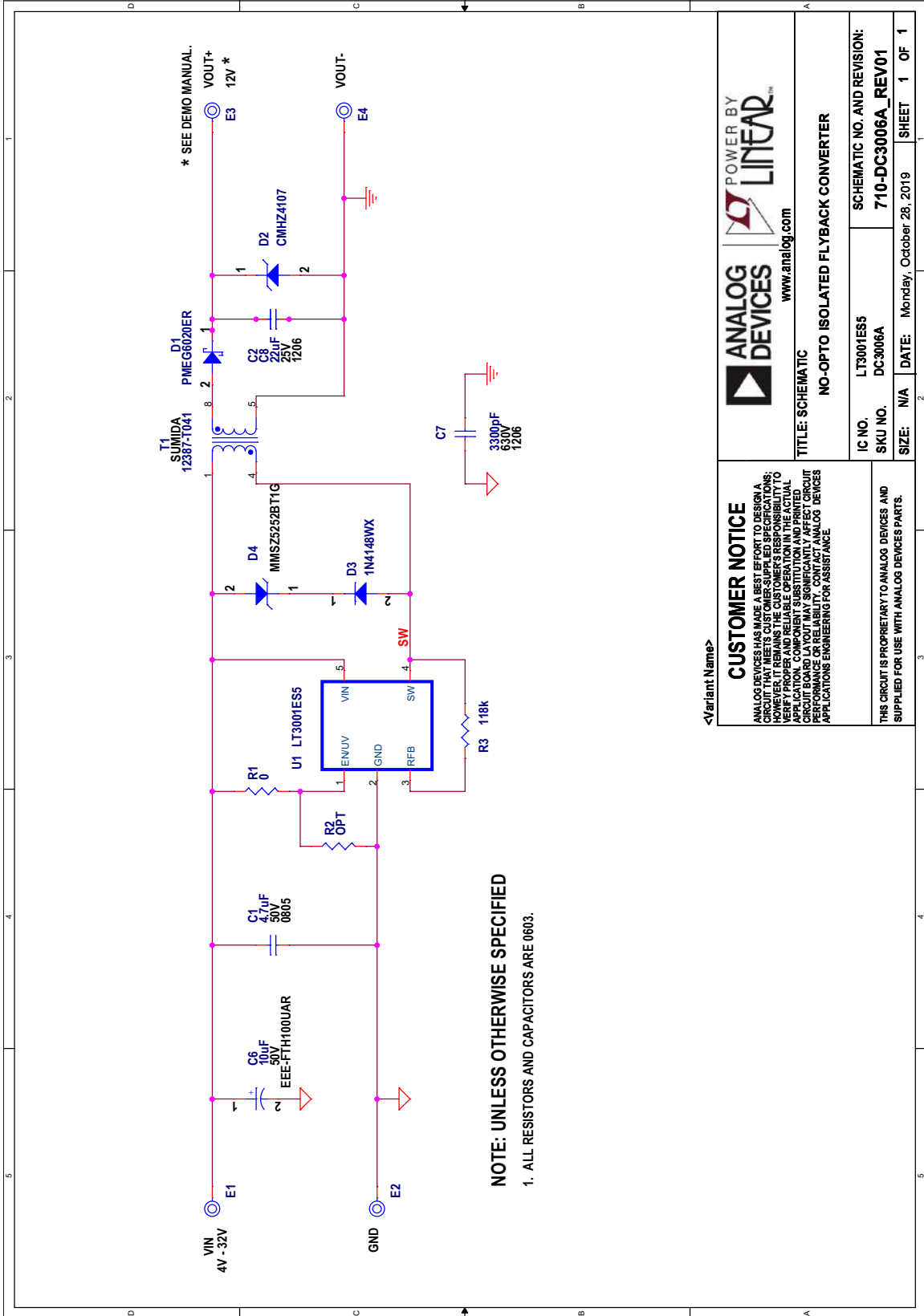

<Variant Name>



POWER BY
LINEAR
www.analog.com

TITLE: SCHEMATIC

NO-OPTO ISOLATED FLYBACK CONVERTER

CUSTOMER NOTICE	IC NO. LT3001ES5
ANALOG DEVICES HAS MADE A BEST EFFORT TO DESIGN A CIRCUIT THAT MEETS CUSTOMER-SUPPLIED SPECIFICATIONS; HOWEVER, IT REMAINS THE CUSTOMER'S RESPONSIBILITY TO VERIFY THAT THE CIRCUIT MEETS ALL APPLICATION-SPECIFIC REQUIREMENTS. ALL APPLICATION COMPONENT SUBSTITUTION AND PRINTED CIRCUIT BOARD LAYOUT MAY SIGNIFICANTLY AFFECT CIRCUIT PERFORMANCE OR RELIABILITY. CONTACT ANALOG DEVICES APPLICATIONS ENGINEERING FOR ASSISTANCE.	SCHEMATIC NO. AND REVISION: 710-DC3006A_REV01
THIS CIRCUIT IS PROPRIETARY TO ANALOG DEVICES AND SUPPLIED FOR USE WITH ANALOG DEVICES PARTS.	SIZE: N/A
	DATE: Monday, October 28, 2019
	SHEET 1 OF 1



ESD Caution

ESD (electrostatic discharge) sensitive device. Charged devices and circuit boards can discharge without detection. Although this product features patented or proprietary protection circuitry, damage may occur on devices subjected to high energy ESD. Therefore, proper ESD precautions should be taken to avoid performance degradation or loss of functionality.

Legal Terms and Conditions

By using the evaluation board discussed herein (together with any tools, components documentation or support materials, the "Evaluation Board"), you are agreeing to be bound by the terms and conditions set forth below ("Agreement") unless you have purchased the Evaluation Board, in which case the Analog Devices Standard Terms and Conditions of Sale shall govern. Do not use the Evaluation Board until you have read and agreed to the Agreement. Your use of the Evaluation Board shall signify your acceptance of the Agreement. This Agreement is made by and between you ("Customer") and Analog Devices, Inc. ("ADI"), with its principal place of business at One Technology Way, Norwood, MA 02062, USA. Subject to the terms and conditions of the Agreement, ADI hereby grants to Customer a free, limited, personal, temporary, non-exclusive, non-sublicensable, non-transferable license to use the Evaluation Board FOR EVALUATION PURPOSES ONLY. Customer understands and agrees that the Evaluation Board is provided for the sole and exclusive purpose referenced above, and agrees not to use the Evaluation Board for any other purpose. Furthermore, the license granted is expressly made subject to the following additional limitations: Customer shall not (i) rent, lease, display, sell, transfer, assign, sublicense, or distribute the Evaluation Board; and (ii) permit any Third Party to access the Evaluation Board. As used herein, the term "Third Party" includes any entity other than ADI, Customer, their employees, affiliates and in-house consultants. The Evaluation Board is NOT sold to Customer; all rights not expressly granted herein, including ownership of the Evaluation Board, are reserved by ADI. CONFIDENTIALITY. This Agreement and the Evaluation Board shall all be considered the confidential and proprietary information of ADI. Customer may not disclose or transfer any portion of the Evaluation Board to any other party for any reason. Upon discontinuation of use of the Evaluation Board or termination of this Agreement, Customer agrees to promptly return the Evaluation Board to ADI. ADDITIONAL RESTRICTIONS. Customer may not disassemble, decompile or reverse engineer chips on the Evaluation Board. Customer shall inform ADI of any occurred damages or any modifications or alterations it makes to the Evaluation Board, including but not limited to soldering or any other activity that affects the material content of the Evaluation Board. Modifications to the Evaluation Board must comply with applicable law, including but not limited to the RoHS Directive. TERMINATION. ADI may terminate this Agreement at any time upon giving written notice to Customer. Customer agrees to return to ADI the Evaluation Board at that time. LIMITATION OF LIABILITY. THE EVALUATION BOARD PROVIDED HEREUNDER IS PROVIDED "AS IS" AND ADI MAKES NO WARRANTIES OR REPRESENTATIONS OF ANY KIND WITH RESPECT TO IT. ADI SPECIFICALLY DISCLAIMS ANY REPRESENTATIONS, ENDORSEMENTS, GUARANTEES, OR WARRANTIES, EXPRESS OR IMPLIED, RELATED TO THE EVALUATION BOARD INCLUDING, BUT NOT LIMITED TO, THE IMPLIED WARRANTY OF MERCHANTABILITY, TITLE, FITNESS FOR A PARTICULAR PURPOSE OR NON-INFRINGEMENT OF INTELLECTUAL PROPERTY RIGHTS. IN NO EVENT WILL ADI AND ITS LICENSORS BE LIABLE FOR ANY INCIDENTAL, SPECIAL, INDIRECT, OR CONSEQUENTIAL DAMAGES RESULTING FROM CUSTOMER'S POSSESSION OR USE OF THE EVALUATION BOARD, INCLUDING BUT NOT LIMITED TO LOST PROFITS, DELAY COSTS, LABOR COSTS OR LOSS OF GOODWILL. ADI'S TOTAL LIABILITY FROM ANY AND ALL CAUSES SHALL BE LIMITED TO THE AMOUNT OF ONE HUNDRED US DOLLARS (\$100.00). EXPORT. Customer agrees that it will not directly or indirectly export the Evaluation Board to another country, and that it will comply with all applicable United States federal laws and regulations relating to exports. GOVERNING LAW. This Agreement shall be governed by and construed in accordance with the substantive laws of the Commonwealth of Massachusetts (excluding conflict of law rules). Any legal action regarding this Agreement will be heard in the state or federal courts having jurisdiction in Suffolk County, Massachusetts, and Customer hereby submits to the personal jurisdiction and venue of such courts. The United Nations Convention on Contracts for the International Sale of Goods shall not apply to this Agreement and is expressly disclaimed.