

REVISIONS					
REV	ECO	DESCRIPTION	DATE	BY	APPR
A1	-	FIRST RELEASE	Jan.12.2018	White	Tommy

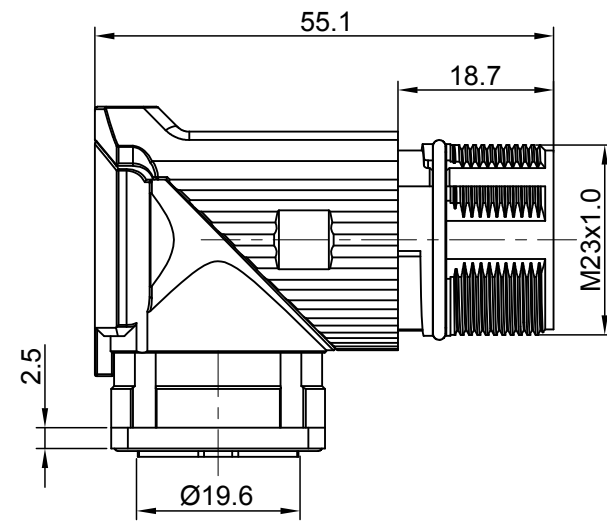

E type, Normal Key

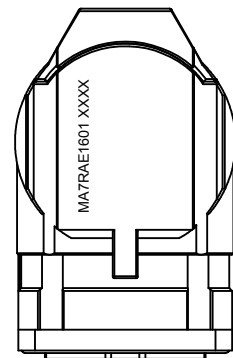
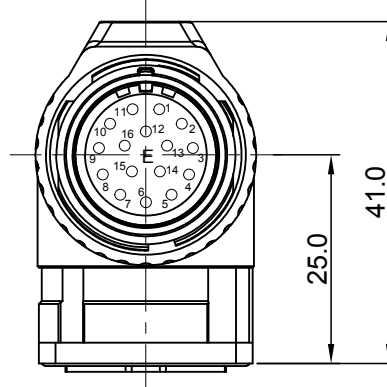

NOTES: UNLESS OTHERWISE SPECIFIED

- MATERIAL:
 - INSULATION INSERT: PA66,UL94 V0
 - SEAL: VITON
 - HOUSING BODY: ZINC DIE CAST, NICKEL PLATED
 - CONTACT: COPPER ALLOY, GOLD PLATED
- SPECIFICATIONS:
 - 2.1 CURRENT RATING: 9 AMPS
 - 2.2 VOLTAGE RATING: 125 V AC/DC
 - 2.3 OPERATING TEMPERATURE: -20°C TO +130°C
 - 2.4 DIELECTRIC WITHSTANDING VOLTAGE: LESS THAN 2 MILLIAMPS CURRENT LEAKAGE @ 2500 VOLTS AC.
 - 2.5 DEGREE OF PROTECTION: IP67 (MATED CONDITION)
 - 2.6 DEGREE OF POLLUTION: 3 PER UL840
 - 2.7 OVERVOLTAGE CATEGORY: III PER UL840
 - 2.8 MATING CYCLE DURABILITY: >500 CYCLES
 - 2.9 RoHS COMPLIANT
- ALL DIMENSIONS ARE FOR REFERENCE USE ONLY.

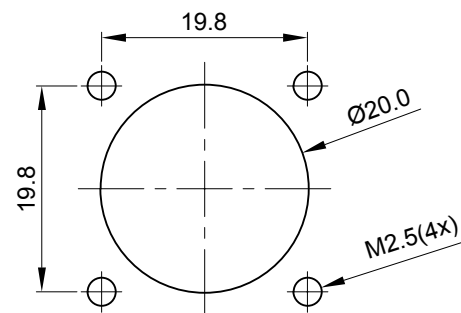

MOUNTING HOLE

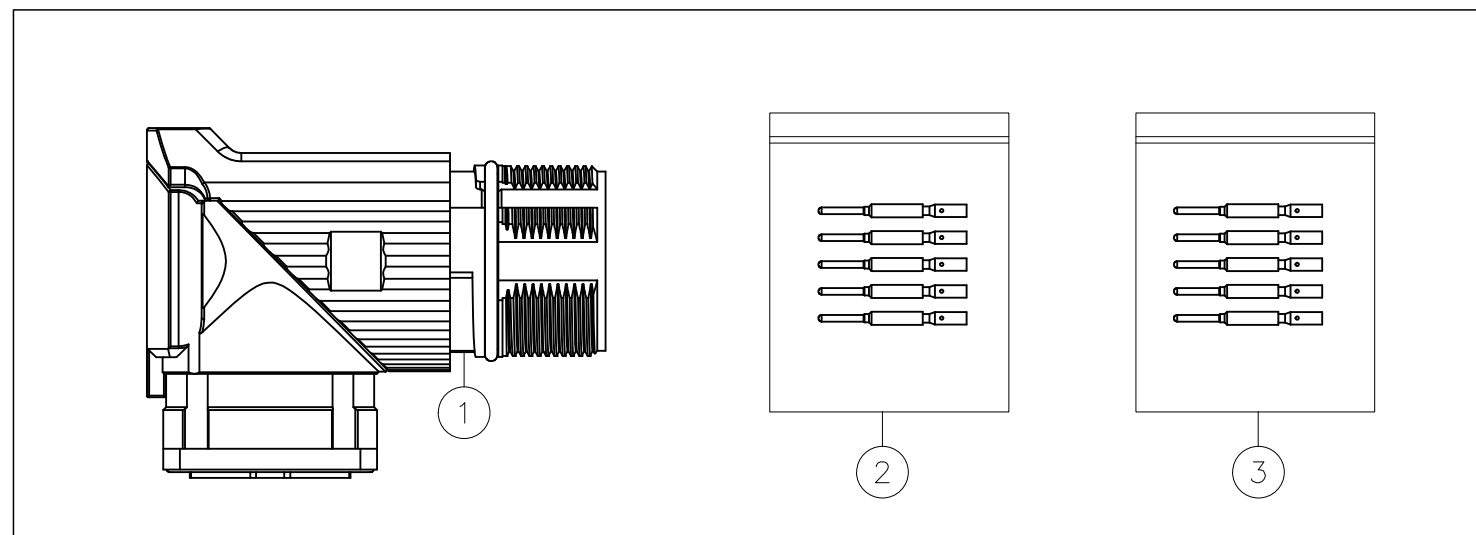
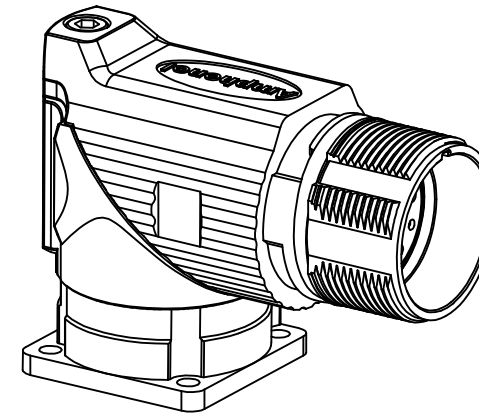
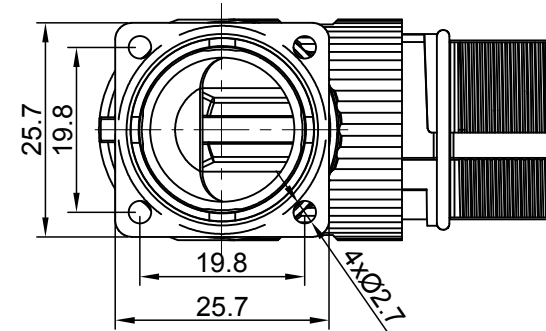

QUANTITY	PART NUMBER	DESCRIPTION	ITEM
16	SC000146	CONTACT, PIN, Ø1.0mm ,Crimp 28~24AWG	3
16	SC000035	CONTACT, PIN, Ø1.0mm, Crimp 22~18AWG	2
1	MA7RAE1601	CONNECTOR	1

MATERIALS LIST

UNLESS OTHERWISE SPECIFIED 1) All dimensions are in metric (mm). 2) Tolerances are as follows: 1 PL DEC ±0.30 Fractions ±1/64 2 PL DEC ±0.15 Angles ±1° 3 PL DEC ±0.08 3) Note reference =	SIGNATURES DRAWN: White CHECKED: Tod ENGINEER: APPROVAL: Tommy	DATE Jan.12.2018 Jan.12.2018 Jan.12.2018	<h1>Amphenol</h1> Sine Systems - www.amphenol-sine.com 44724 Morley Drive Clinton Township, MI 48036
	MATERIAL SPECIFICATIONS: PROCESS SPECIFICATIONS: NEXT ASSY:	CUSTOMER: THIS DRAWING IS SUPPLIED FOR INFORMATION ONLY. DESIGN FEATURES, SPECIFICATIONS AND PERFORMANCE DATA SHOWN HEREON ARE THE PROPERTY OF THE AMPHENOL CORPORATION. NO RIGHTS OF REPRODUCTION ARE IMPLIED. ALL DIMENSIONS ARE SUBJECT TO NORMAL MANUFACTURING VARIATIONS.	
SIZE: B C- SCALE: NONE		DWG NO: MA7RAE1601-KIT	REVISION: A1
SHEET 1 OF 1			

TITLE: KIT,M23A,REC.,RA,16P,E TYPE
 DWG NO: MA7RAE1601-KIT
 REV: A1
 SH: 1
 OF: 1