

Typical unit

PRODUCT OVERVIEW

The MYBSS054R6EBF is an isolated, regulated, DC-DC converter that has an input range of 10.8-27Vdc with a typical efficiency of 90%, and full 2250 Volt DC isolation.

The MYBSS054R6EBF is ideal for PoE PSE Devices.

Module has self-protection features. These include input undervoltage lockout and output current limit. The outputs current limit is using the hiccup autorestart technique.

FEATURES

- 30W DC-DC converter
- 10.8-27V Input Voltage range
- 22.4 x 35.5 x 8.9mm Size
- 90% efficiency (typical)
- Surface mount module
- 2250Vdc Input-Output Isolation
- Operating Temperature range -40 to +85 °C

Typical Application

- Gateway
- Router
- Switch
- Audio visual receiver
- Roadside unit
- Controller

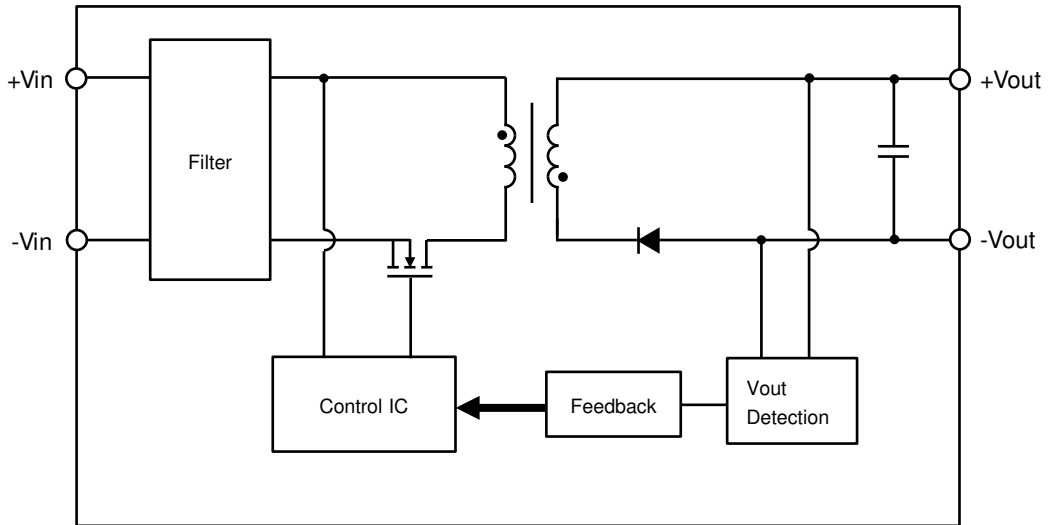
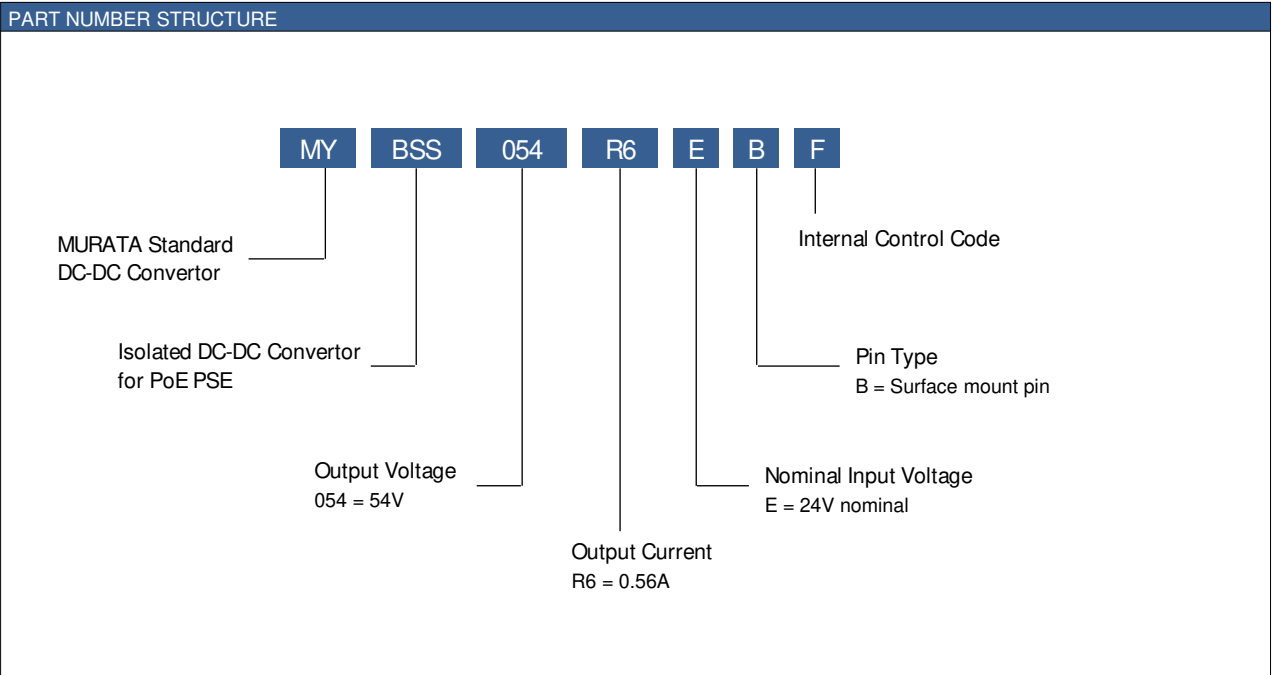

Figure 1. Simplified Block Diagram
Typical topology is shown.

PERFORMANCE SPECIFICATIONS SUMMARY AND ORDERING GUIDE													
Model Number	Output						Input				Efficiency (%)		Package (mm)
	Vout (Vdc)	Iout (A,Max.)	Power (W)	R/N Typ. (mVp-p)	Regulation Typ.		Vin Nom. (Vdc)	Range (Vdc)	lin, no load Typ.(mA)	lin, full load Typ.(A)	Min.	Typ.	
					Line (%)	Load (%)							
MYBSS054R6EBF	54	0.56	30	300	±0.1	±0.1	24	10.8-27	25	1.4	86	90	22.4 x 35.5 x 8.9

1. Please refer to the Part Number Structure for additional ordering information and options.
2. All specifications are at nominal line voltage, full load, +25°C unless otherwise stated.



Product Marking

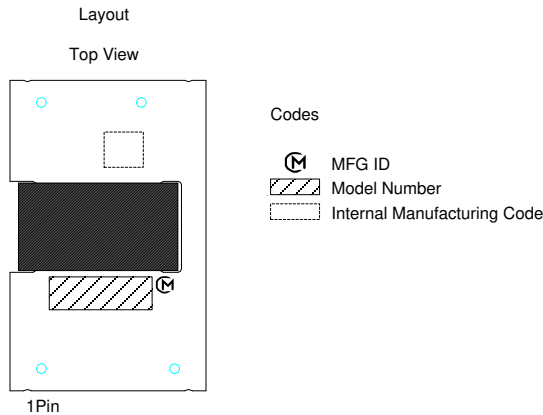

FUNCTIONAL SPECIFICATIONS, MYBSS054R6EBF

ABSOLUTE MAXIMUM RATINGS	Conditions	Minimum	Typical / Nominal	Maximum	Units
Input Voltage, Continuous		0		27	Vdc
Input Voltage, Transient	100ms max. duration			30	Vdc
Isolation Voltage	Input to output, Leak current 1mA max for 1minute at +25°C/60%RH.			2250	Vdc
Output Power		0		30	W
Output Current	Current-limited, no damage, short-circuit protected	0		0.56	A
Storage Temperature Range	Vin = Zero (no power)	-40		90	°C
Absolute maximums are stress ratings. Exposure of devices to greater than any of these conditions may adversely affect long-term reliability. Proper operation under conditions other than those listed in the Performance/Functional Specifications Table is not implied or recommended.					
INPUT					
Operating Voltage Range		10.8	24	27	Vdc
Start-up threshold	Rising input voltage		10		Vdc
Hysteresis Voltage	Input voltage difference between start-up and undervoltage shutdown		1		Vdc
Internal Filter Type			Pi		
Input current					
Full Load Conditions	Vin = nom., Iout = max		1.4		A
Low Line Input current	Vin = min., Iout = max.		3.1		A
No Load Current	Vin = nom., Iout = 0A.		25		mA
GENERAL and SAFETY					
Efficiency	Vin = nom., full load	86	90		%
Isolation					
Isolation Voltage	Input to output, Leak current 1mA max for 1minute at +25°C/60%RH.	2250			Vdc
Insulation Safety Rating			Functional		
Isolation Capacitance			1500		pF
Calculated MTBF	Telcordia SR-332, issue 1, class 3, ground fixed, Ta = +25°C		2242		Hours x 10 ³
DYNAMIC CHARACTERISTIC					
Fixed Switching Frequency	Iout = max		170		kHz
Vin Startup delay time	Power On to Vout regulated		160		ms
Vout Rise Time	From 10%-90% of Vout		20		ms
Dynamic Load Response	50-100-50% load step to 1% of Vout		250		µSec
Dynamic Load Peak Deviation	same as above		±200		mVdc

FUNCTIONAL SPECIFICATIONS, MYBSS054R6EBF(CONT.)

OUTPUT	Conditions	Minimum	Typical / Nominal	Maximum	Units
Total Output Power		0		30	W
Voltage					
Nominal Output Voltage	all conditions	52.38	54	55.62	Vdc
Overvoltage Protection			None		Vdc
Current					
Output Current Range		0		0.56	A
Current Limit Inception		0.588			A
Short circuit protection method	Hiccup current limiting		Non-latching		
Regulation					
Line Regulation	Vin=min. to max., Vout=nom., full load		±0.1		% of Vout
Load Regulation	Iout = min. to max.		±0.1		% of Vout
Ripple and Noise	150 MHz BW, Cout=0.1µF MLCC paralleled with 10µF and 47µF Low ESR Electrolytic Capacitor		300		mV pk-pk
Maximum Capacitive Loading	Low ESR Electrolytic Capacitor	33		56	µF
MECHANICAL					
Outline Dimensions	L x W x H		22.4 x 35.5 x 8.9		mm
Weight			12.5		Grams
Pin Diameter			1.57		mm
Pin Material			Copper alloy		
ENVIRONMENTAL					
Operating Ambient Temperature Range		-40		85	°C
Storage Temperature	Vin = Zero (no power)	-40		90	°C
Thermal Protection/Shutdown	Measured at hotspot		None		°C
Electromagnetic Interference Conducted, EN55022/CISPR22	External filter is required		B		Class

Specification Notes

Unless otherwise noted, all specifications are typical at nominal input voltage, nominal output voltage and full load. General conditions are +25° C ambient temperature, near sea level altitude, natural convection airflow. All models are tested and specified with external parallel 47µF, 0.1µF and 10µF output capacitors (See Technical Notes).

PERFORMANCE DATA, MYBSS054R6EBF

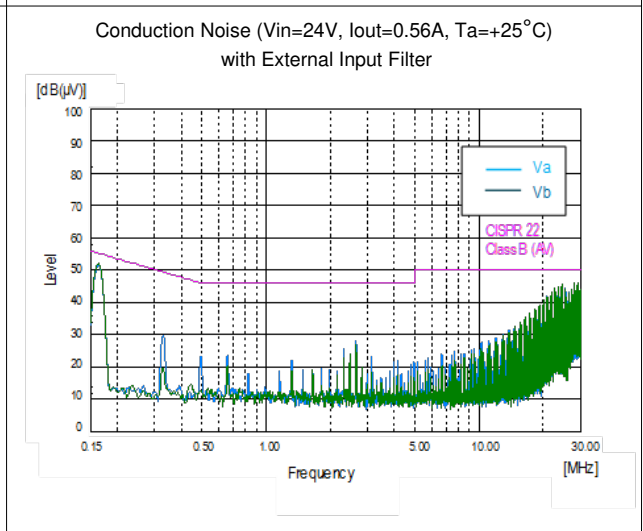
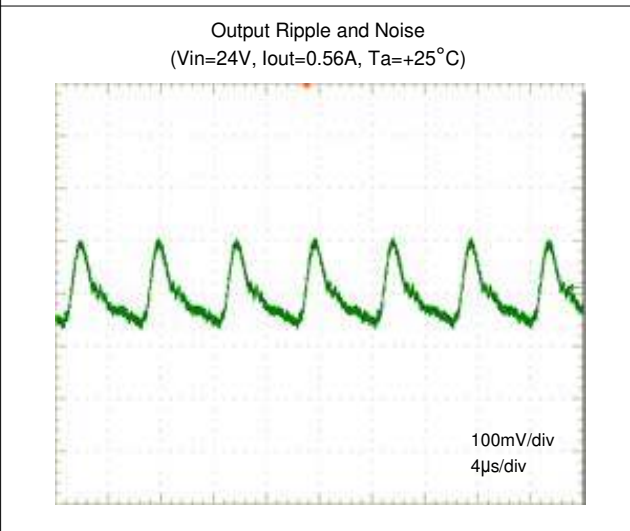
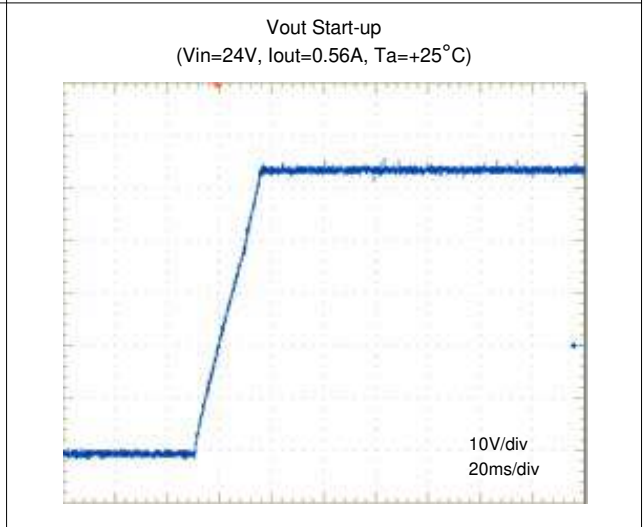
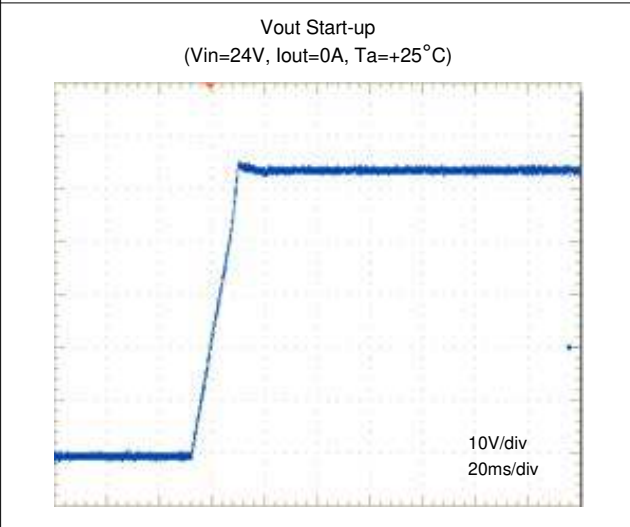
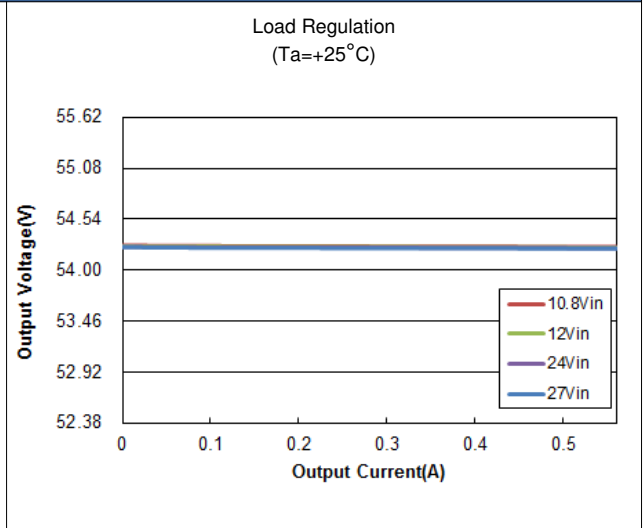
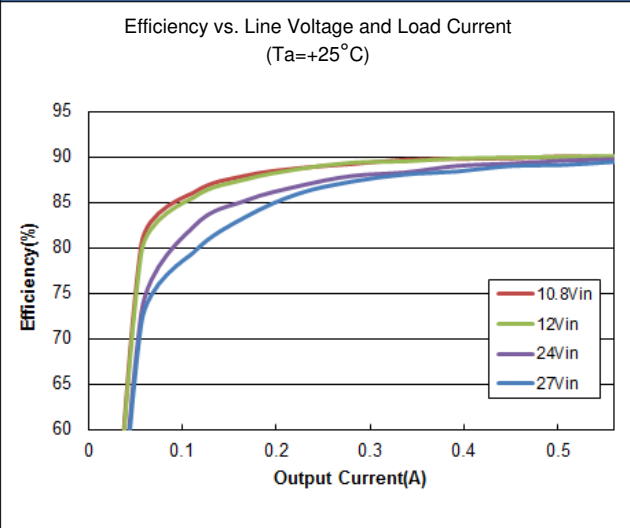

PERFORMANCE DATA, MYBSS054R6EBF(CONT.)

Thermal Derating

Unit under test (UUT) is covered by acrylic box to avoid airflow.
($V_{in}=24V$, See Technical Notes)

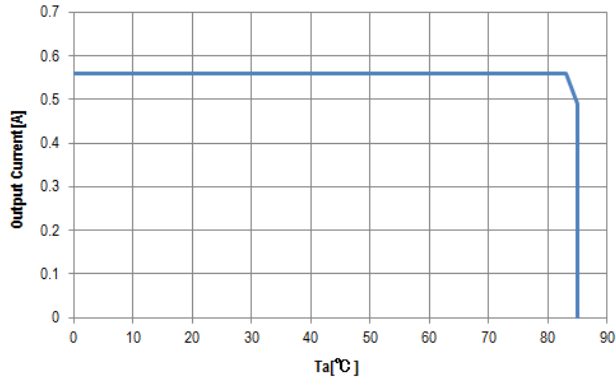

MECHANICAL SPECIFICATIONS

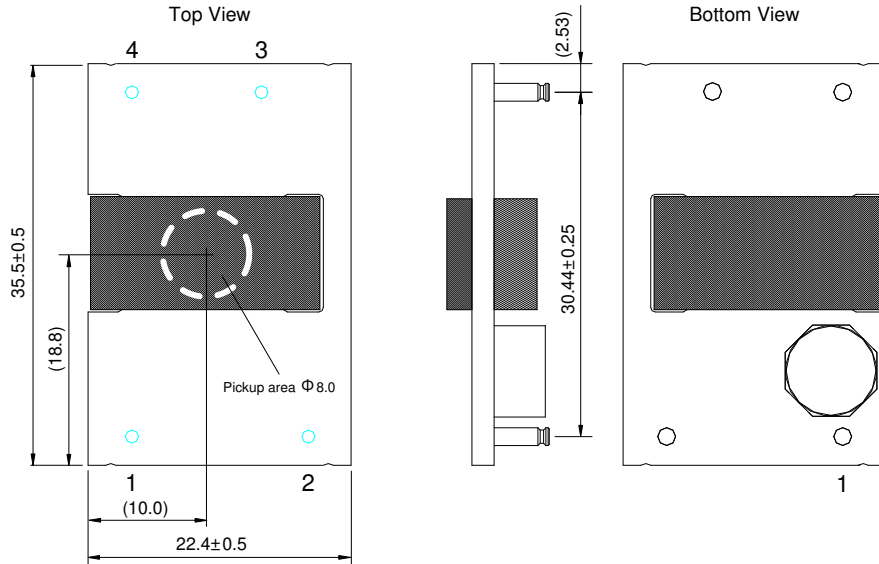

[Unit : mm]

INPUT / OUTPUT CONNECTIONS			
Pin	Designation	Function	Pin size
1	+Vin	Positive Input Voltage	Φ1.57
2	-Vin	Negative Input Voltage	Φ1.57
3	-Vout	Negative Output Voltage	Φ1.57
4	+Vout	Positive Output Voltage	Φ1.57

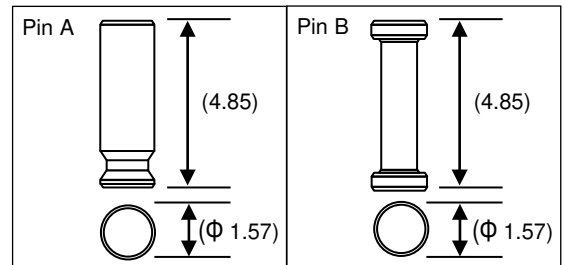

*Pin would be used either Pin A or Pin B.

RECOMMENDED FOOTPRINT (TOP VIEW)

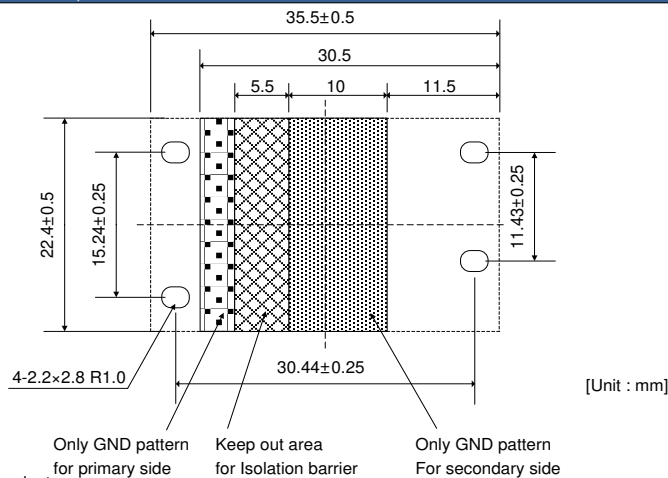

[Unit : mm]

*Do not place parts in areas under the product.

Lay out high-impedance wiring such as signal lines as far away from the product as possible.

PACKAGING INFORMATION (SURFACE MOUNT, MSL Rating 1)

Packaging form

The products are placed in the Emboss Tape as below

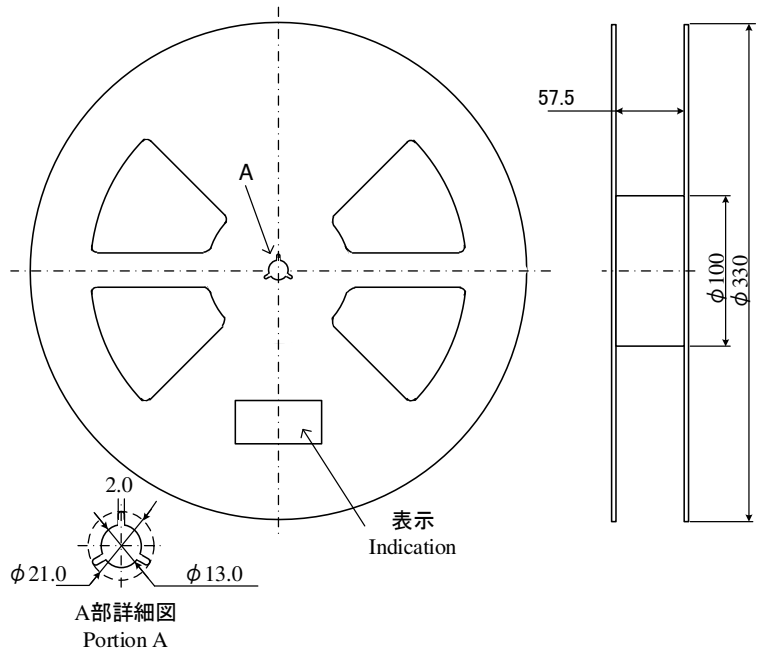
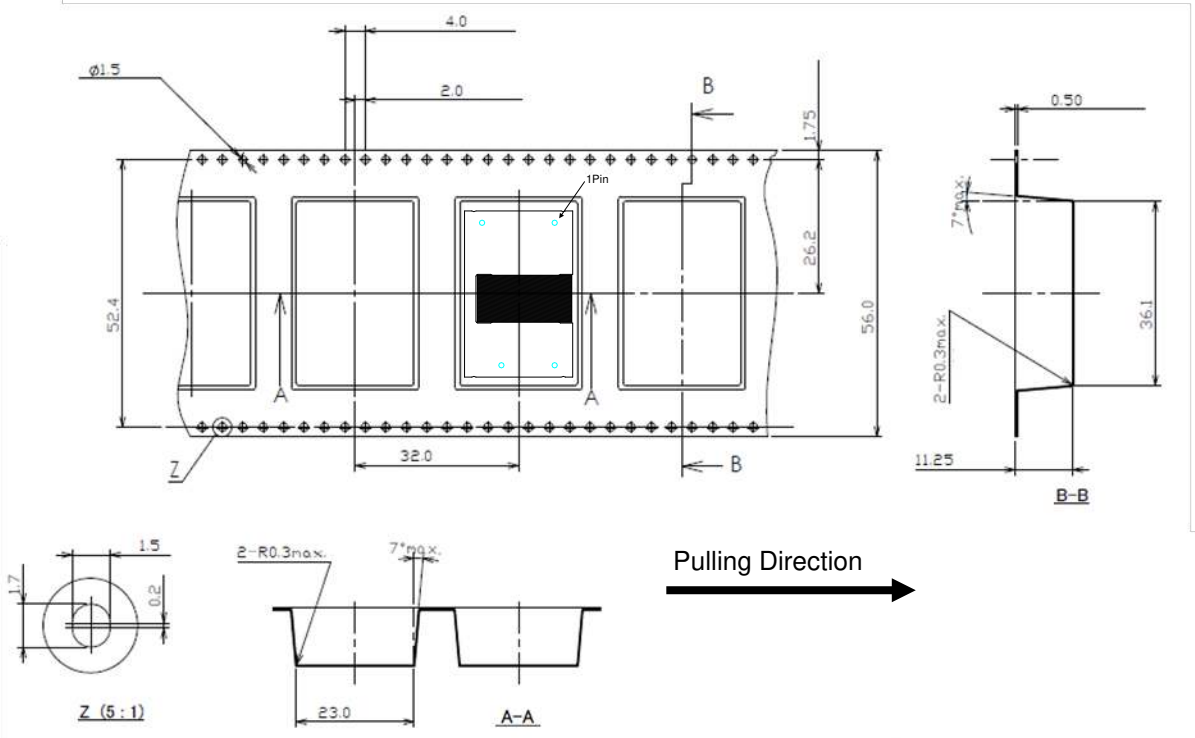

[Unit:mm]

PACKAGING INFORMATION (SURFACE MOUNT, MSL Rating 1)

Packaging form
Taping Specification

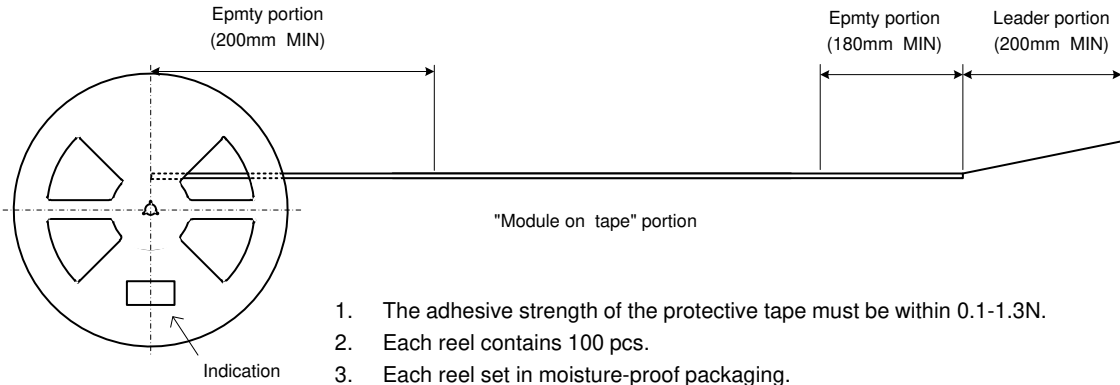

1. The adhesive strength of the protective tape must be within 0.1-1.3N.
2. Each reel contains 100 pcs.
3. Each reel set in moisture-proof packaging.
4. The deficiency per reel is 0 piece.
5. The reel shows customer part number, Murata part number and quantity.
6. The color of reel is not designated.

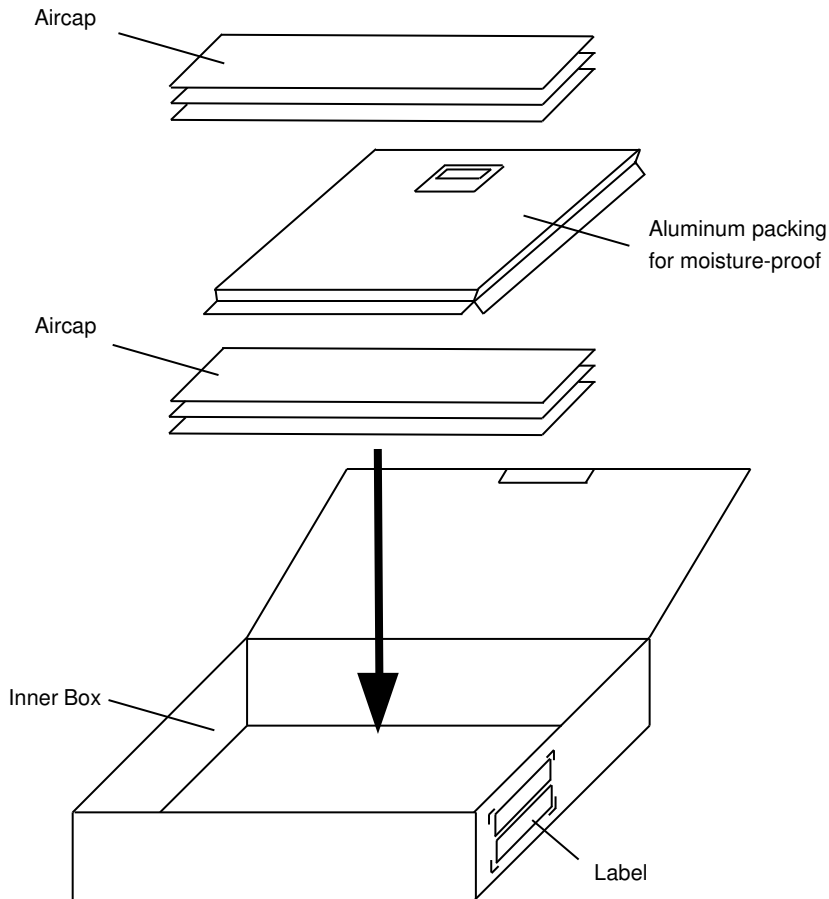

TECHNICAL NOTES

Over Current Protection

Over Current Protection operates with a controller circuit failure or over-load condition, and DC-DC converter will enter hiccup mode. After rejected the abnormal mode, DC-DC converter will automatically restart.

External Input Capacitor

This capacitor minimizes the influence from the wiring to the input or the components like switch for output performance. Please evaluate the board to choose the adequate value.

Test Circuit

The initial values in Functional Specification are measured in the following test circuit.

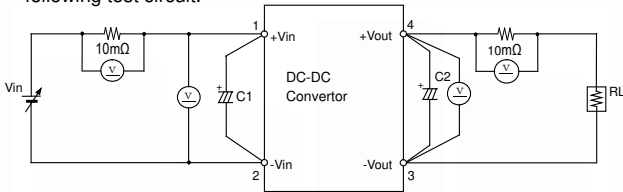

- C1 : Low Impedance Electrolytic Capacitor 100μF
- C2 : Low Impedance Electrolytic Capacitor 33~56μF
- RL : Electronic Load Device : LN-1000A-G7 KEISOKU GIKEN equivalent
- Vin : DC Power Supply :Model HP6675A KEYSIGHT equivalent
- V : Digital Multimeter :Model HP34401A KEYSIGHT equivalent

When deviating from the above, DC-DC converter may operate abnormally. It should be fully confirmed on your board before use.

Ripple Noise Test

Output ripple noise is measured using designated external output components, circuits and layout as shown below.

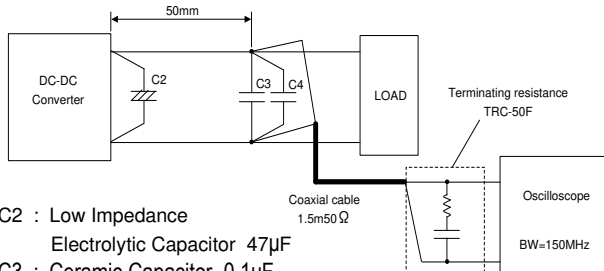

- C2 : Low Impedance Electrolytic Capacitor 47μF
- C3 : Ceramic Capacitor 0.1μF
- C4 : Ceramic Capacitor 10μF

Conduction Noise

The external input filter is installed and the circuit diagram is shown below.

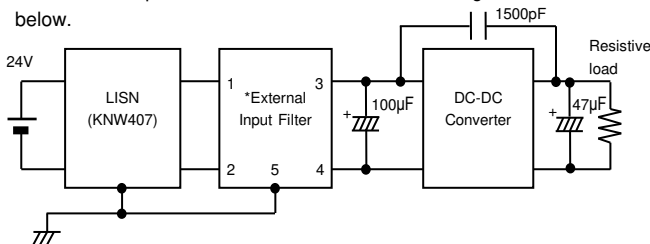

***External input filter**

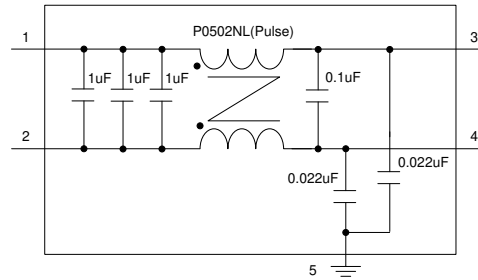

Thermal Derating Condition

The output current is limited by the derating curve. The derating curve in this datasheet illustrate typical operation under a variety of conditions.

DC-DC Converter is tested on a 101.6x188mm, 2 layers Copper evaluation board at Vin=24V.

The Unit Under Test (UUT) is set up as shown below. UUT is covered by acrylic box to avoid airflow.

The temperature measurement points are shown below table. The temperature of measurement points should not exceed the maximum temperatures in the below table.

Position	Description	Max temperature
P1	FET	T _{P1MAX} = 124°C
P2	Opto-coupler	T _{P2MAX} = 105°C

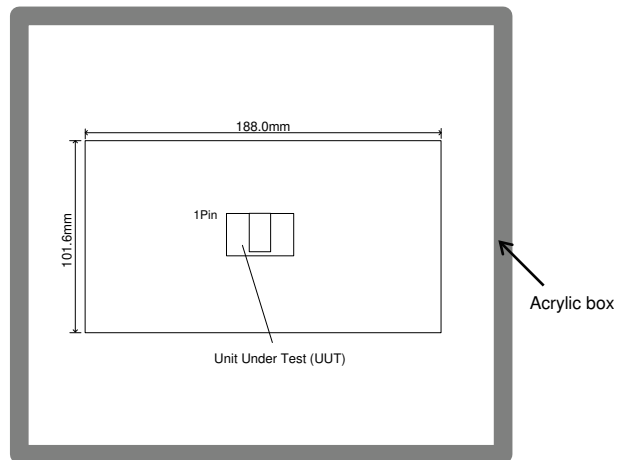
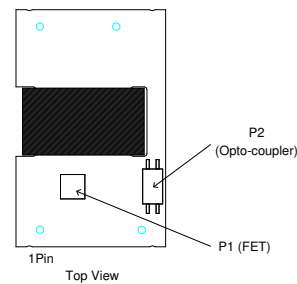

SMT Reflow Soldering Guidelines

The surface-mount reflow solder profile is shown below.
This graph should be used only as a guideline.

Reflow Soldering Profiles : JEDEC IPC/JEDEC J-STD-020D

Soldering temperature	245°C +0/-5°C
Soldering time	30 seconds, 240°C-245°C
Heating time	60~150 seconds, 217°C min.
Preheat time	60~120 seconds, 150°C-200°C
Programming rate	3°C /sec.max., 217°C-245°C
Descending rate	6°C /sec.max.
Total soldering time	8 minutes max., 25°C-245°C
Time	1time

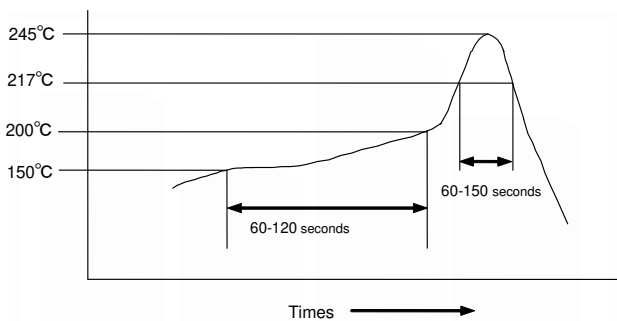

Do not vibrate for the products on reflow. Please need to take care temperature control because mounted parts may come off if the product is left under the high temperature. Do not mount on backside of the board.

Many other factors influence the success of SMT reflow soldering. Since your production environment may differ, please thoroughly review these guidelines with your process engineers.

Scope

This datasheet is applied to MYBSS054R6EBF.

- Specific applications: Consumer Electronics, Industrial Equipment

Limitation of Applications

The products listed in the datasheet (hereinafter the product(s) is called the "Product(s)") are designed and manufactured for applications specified in the specification or the datasheet. (hereinafter called the "Specific Application"). We shall not warrant anything in connection with the Products including fitness, performance, adequateness, safety, or quality, in the case of applications listed in from (1) to (11) written at the end of this precautions, which may generally require high performance, function, quality, management of production or safety. Therefore, the Product shall be applied in compliance with the specific application.

We disclaim any loss and damages arising from or in connection with the products including but not limited to the case such loss and damages caused by the unexpected accident, in event that (i) the product is applied for the purpose which is not specified as the specific application for the product, and/or (ii) the product is applied for any following application purposes from (1) to (11) (except that such application purpose is unambiguously specified as specific application for the product in our catalog specification forms, datasheets, or other documents officially issued by us*).

- (1) Aircraft equipment
- (2) Aerospace equipment
- (3) Undersea equipment
- (4) Power plant control equipment
- (5) Medical equipment
- (6) Transportation equipment (such as vehicles, trains, ships)
- (7) Traffic control equipment
- (8) Disaster prevention / crime prevention equipment
- (9) Industrial data-processing equipment
- (10) Combustion/explosion control equipment
- (11) Application of similar complexity and/or reliability requirements to the applications listed in the above

For exploring information of the Products which will be compatible with the particular purpose other than those specified in the datasheet, please contact our sales offices, distribution agents, or trading companies with which you make a deal, or via our web contact form.

Contact form: <https://www.murata.com/contactform>

*We may design and manufacture particular Products for applications listed in (1) to (11). Provided that, in such case we shall unambiguously specify such Specific Application in specification or datasheet without any exception. Therefore, any other documents and/or performances, whether exist or non-exist, shall not be deemed as the evidence to imply that we accept the applications listed in (1) to (11).

Fail-safe function

Be sure to add an appropriate fail-safe function to your finished product to prevent secondary damage in the unlikely event of an abnormality function or malfunction in our product.

Please connect the input terminal by right polarity. If you mistake the connection, it may break the DC-DC converter. In the case of destruction of the DC-DC converter inside, over input current may flow. Please add a diode and fuse as following to protect them.

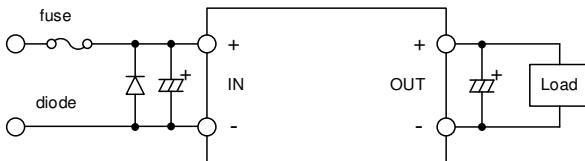

Please select diode and fuse after confirming the operation.



Note

1. Please make sure that your product has been evaluated in view of your specifications with our product being mounted to your product.
2. You are requested not to use our product deviating from the reference specifications.
3. If you have any concerns about materials other than those listed in the RoHS directive, please contact us.
4. Please don't wash this product under any conditions.

Storage

Please store this product in an environment where the temperature/humidity is stable in the range 0 to 40° C/10 to 75%RH and no direct sunlight. Use the product within 6 months after delivery.

Please avoid storage conditions where humidity and temperature change rapidly, as that may cause condensation on the product, which might degrade the quality of the product.

Please do not store the product environments that are dusty, in direct exposure to sea breeze, or in an atmosphere containing corrosive gas (Cl₂, NH₃, SO₂, NO_x and so on).

Operational environment and operational conditions

This product is not chemical-proof or rust-proof.

In order to prevent this product from leakage of electricity and/or abnormal temperature increase, do not use the product under the following circumstances:

- (1) in an atmosphere containing corrosive gas (Cl₂, NH₃, SO₂, NO_x and so on).
- (2) in a dusty place.
- (3) in a place exposed to direct sunlight.
- (4) in such a place where water splashes or in such a humid place where water condenses.
- (5) in a place exposed to sea breeze.
- (6) in any other places similar to the above (1)through (5).

Operational Conditions

Please use the product within specified values (power supply, temperature, input, output and load condition etc.). Input voltage drops for line impedance, so please make sure that input voltage is within in specified values.

If the product is used over the specified values, it may damage the product, reduce the quality, and even if the products can endure the condition for short time, it may cause degradation of the reliability.

Note Prior to use

If you apply high static electricity, voltage higher than rated voltage or reverse voltage to the product, it may cause defects in the products or degrade the reliability.

Please avoid the following items:

1. Over rating power supply, reverse power supply or not-enough connection of input voltage and 0V(DC)line
2. Electrostatic discharge by production line and/or operator
3. Electrified product by electrostatic induction

Do not subject product to excessive mechanical shock. If you drop the product on the floor it might cause a crack to the core of inductors and monolithic ceramic capacitors.

Also please pay attention to handling; the mounted parts can be dislodged if subjected to excessive force.

Transportation

If you transport the product, please pack it so that the package will not be damaged by mechanical vibration or mechanical shock, and please educate and guide the carrier to prevent rough handling.

Product Specification

Product Specification in this datasheet are as of August 2020. Specifications and features may change in any manner without notice. Please check with our sales representatives or product engineers.

Contact form

<https://www.murata.com/contactform?Product=Power%20Device>

Disclaimers

The information described in this data sheet was carefully crafted for accuracy. However this product is based on the assumption that it will be used after thoroughly verifying and confirming the characteristics and system compatibility. Therefore, Murata is not responsible for any damages caused by errors in the description of the datasheet.

Murata constantly strives improve the quality and reliability of our products, but it is inevitable that semiconductor products will fail with a certain probability. Therefore regardless of whether the use conditions are within the range of this data sheet, Murata is not responsible for any damage caused by the failure of this product., (for example, secondary damage, compensation for accidents, punitive damage, loss of opportunity, and etc.) Also, regardless of whether Murata can foresee the events caused by the failure of our product, Murata has no obligations or responsibilities.

The buyer of this product and developer of systems incorporating this product must analyze, evaluate, and make judgements at their own risk in designing applications using this product. The buyer and the developer are responsible for verifying the safety of this product and the applications, and complying with all applicable laws, regulations, and other requirements.

Furthermore, the buyer and developer are responsible for predicting hazards and taking adequate safeguards against potential events at your own risk in order to prevent personal accidents, fire accidents, or other social damage. When using this product, perform thorough evaluation and verification of the safety design designed at your own risk for this product and the application.

Murata assumes that the buyer and developer have the expertise to verify all necessary issues for proper use of the product as described above and to take corrective action. Therefore, Murata has no liability arising out of the use of the product. The buyer and developer should take all necessary evaluations, verifications, corrective actions and etc., in your own responsibility and judgment.

This data sheet does not guarantee or grant any license to the information, including patents, copyrights, and other intellectual property rights, of the Murata or third parties. Regardless of whether the information described in this datasheet is express or implied, Murata does not take any responsibility or liability for any claims, damages, costs, losses, etc. relating to intellectual property rights or other rights from third parties due to the use of these information.

Patent Statement

Murata products are protected to under one or more of the U.S. patents.

Copyright and Trademark

©2023Murata Manufacturing Co., Ltd. All rights reserved.



This product is subject to the following [operating requirements](#) and the [Life and Safety Critical Application Sales Policy](#):
Refer to: <https://power.murata.com/en/requirements>

Murata Manufacturing Co., Ltd makes no representation that the use of its products in the circuits described herein, or the use of other technical information contained herein, will not infringe upon existing or future patent rights. The descriptions contained herein do not imply the granting of licenses to make, use, or sell equipment constructed in accordance therewith. Spec and cautions are subject to change without notice.
© 2023 Murata Manufacturing Co., Ltd

Revision History

REV	DATE	DESCRIPTION	PAGE NUMBER
A02	Feb-2023	Add Pin B to use either Pin A and Pin B.	P7