

SPECIFICATIONS



Model Number: PT2B3K
Part Number: 17000698A

Version: 01
 Apr 01, 2017

Mechanical Drawing:

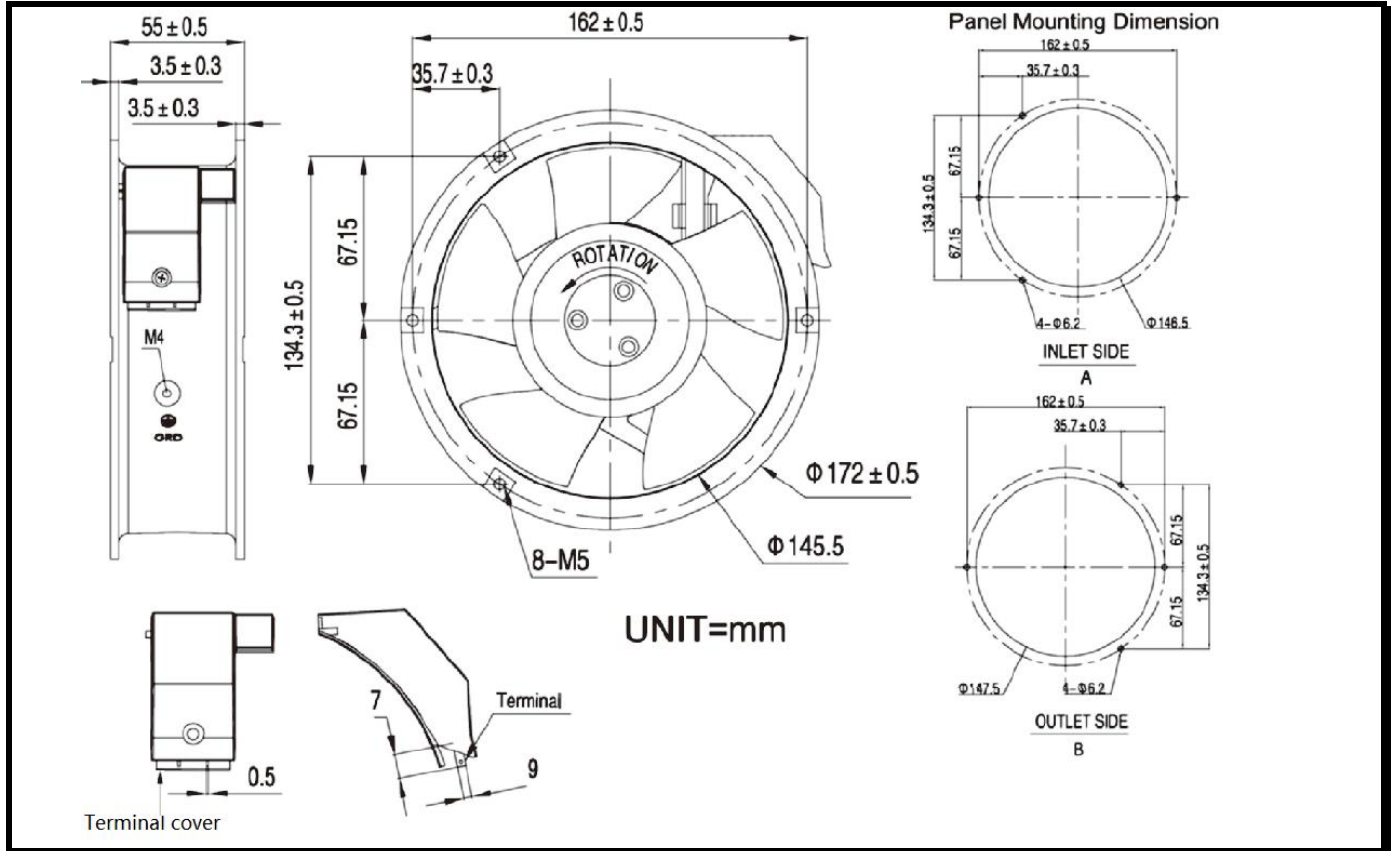

Motor:

Nominal Voltage = 115 VAC
 Frequency = 50 / 60 Hz
 Nominal Running Current = 0.250 / 0.260 amps
 Running Power = 27/30 watts
 Average Speed = 2800 / 3300 RPM
 Bearings = Ball
 Air Flow = 218/245 CFM
 Acoustic = 59/62 dBA

Construction:

Venturi: High quality magnesium alloy die-casting frame with ED coating+powder coating
 Propeller: Magnesium alloy ED coating+painting

Agency Approvals:

UL, CE

Additional Features:

Permanent Split Capacitor Motor
 Thermal Protection
 Automatic Restart Capability
 Operating Temperature: -10°C to 70°C
 Storage Temperature: -40°C to 85°C
 Ingress of protection: IP55

Additional Features:

0.110" Terminals

Life Expectancy:

Temperature	Hours
20°C	60,000
40°C	50,000
60°C	40,000
90°C	20,000

PQ Curve:

