

REVISIONS			RELEASED	
SYM	DESCRIPTION	DATE	APPROVED	
M	38301 REDRAWN, ADDED FIND NO 14	99/01/27	RS	
N	06-00066 ADDED ITEM 15, UPDATED VIEW TO SHOW PHILLIPS HEAD SCREWS	05/12/19	CB	
P	11-024834 ITEM 7 WAS -054	11/12/01	CB	

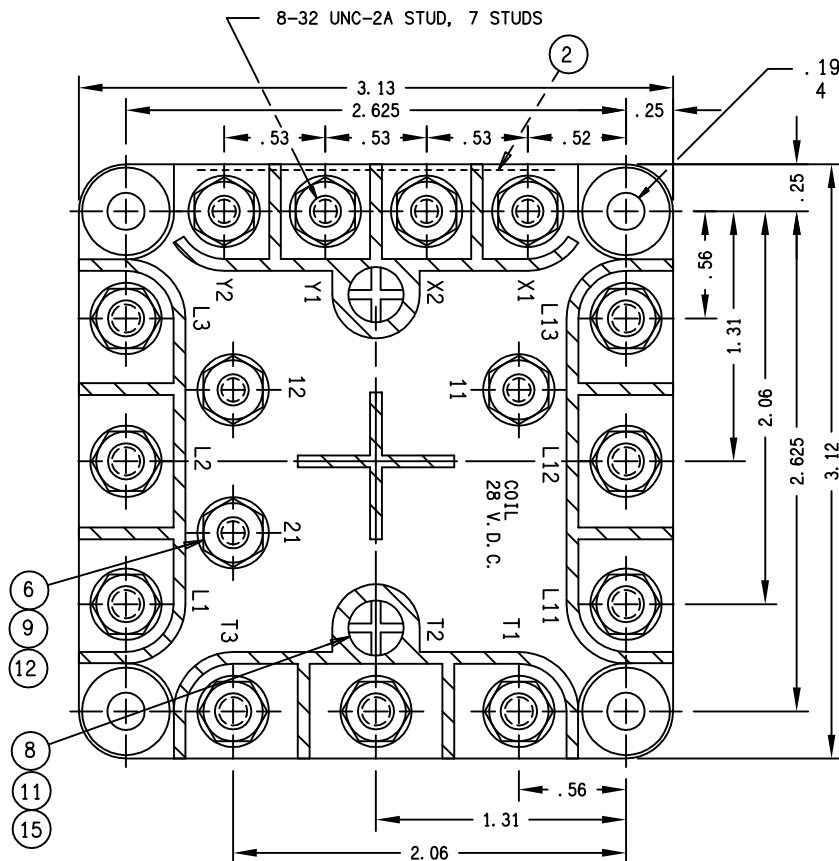

OPERATING VOLTAGE  
 COIL  
 CONTACTS  
 CONTACT RATING  
 RES. IND  
 MOTOR  
 CONTACTS  
 PICKUP VOLTAGE  
 DROPOUT VOLTAGE  
 COIL CURRENT AT 29 V  
 INITIAL  
 HOLDING  
 AUX CONTACT  
 AUX. CONTACT RATING  
 MAX. WEIGHT

28 VDC  
 200 VAC, 400 HZ  
 60 AMP/PHASE  
 40 AMP/PHASE  
 T. P. D. T. N. O.  
 18 V. MAX. (HOT)  
 7, +0, -5.5 VDC  
 5.0 AMP  
 .5 AMP  
 SPST N. O. EACH SIDE  
 5 AMP, 28 VDC  
 1 LB. 8 OZ.

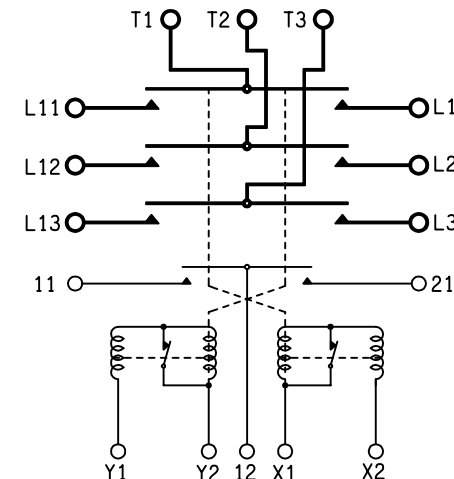

NOTES:  
 1. TOLERANCE ON ALL TERMINAL LENGTHS TO BE ± .06

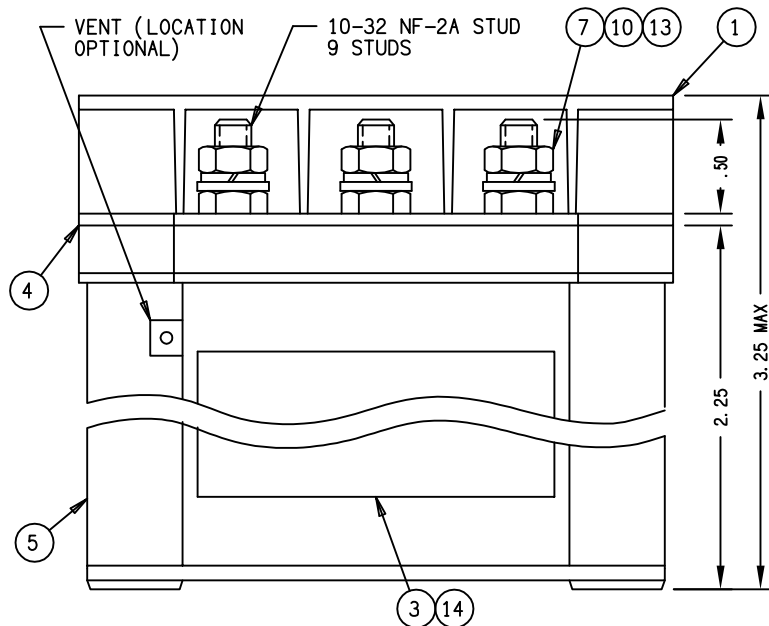

15	2	51701-310	WASHER .203 X .115 X .015			MYLAR
14	1	39529-001	OVERLAY-NAME PLATE			
13	9	51810-054	WASHER - LOCK NO. 10 SPLIT		AN935B10	BRONZE
12	7	51808-064	WASHER - LOCK NO. 8 SPLIT		AN935B8	BRONZE
11	2	51806-031	WASHER - LOCK NO. 6 INT. TOOTH		AN936A6B	BRONZE
10	9	51712-194	WASHER- 7/16 X .203 X .031		AN961-10	BRASS
9	7	51712-104	WASHER- 3/8 X 11/64 X .032		AN961-8	BRASS
8	2	51206-641	SCREW-6-32 X 3/4 RD. HD.		AN515PB6-12	BRASS
7	9	50410-174	NUT-10-32 X 5/16 X 9/64 HEX		MS35650-305	BRASS
6	7	50408-034	NUT-8-32 X 5/16 X 1/8 HEX		MS35649-286	BRASS
5	1	19390-010	RELAY ASSEMBLY - PRIMARY			
4	1	17985-001	PLATE - BASE COVER			
3	1	16043-001	PLATE - NAME			
2	1	12771-001	PLATE - WARNING			
1	1	12531-001	SHIELD - TERMINAL			

FIND NO	QTY REQD	PART OR IDENTIFYING NO	NOMENCLATURE OR DESCRIPTION	FSCM NO	DRAWING OR SPECIFICATION	MATERIAL OR NOTE
---------	----------	------------------------	-----------------------------	---------	--------------------------	------------------

TOLERANCES: UNLESS OTHERWISE SPECIFIED			 Division 175 N. DIAMOND STREET MANSFIELD, OHIO 44902		
2 PL DEC.	3 PL DEC.	ANGLES			
± .06	± .010	± 1°	DR BY	RLS	99/02/18
			CHK BY	RS	99/02/24
			ENGR	WER	99/02/24
			MFG	MB	99/02/24
REF.			SIZE	CODE IDENT	
VERTOL	A02ES100-5		C	74063	
BENDIX	3B4-1 & 1A		SCALE	NONE SHEET	

CONTACTOR - T. P. D. T. N. O. 093

DWG NO. B-140V

REF TE P/N 1-1616043-0