

MATERIALS AND FINISHES

BODIES: BRASS  
PLATED GOLD OVER NICKEL

CONTACTS: BERYLLIUM COPPER  
PLATED: GOLD OVER NICKEL

INSULATORS: TEFLON

BLOCK: STANYL

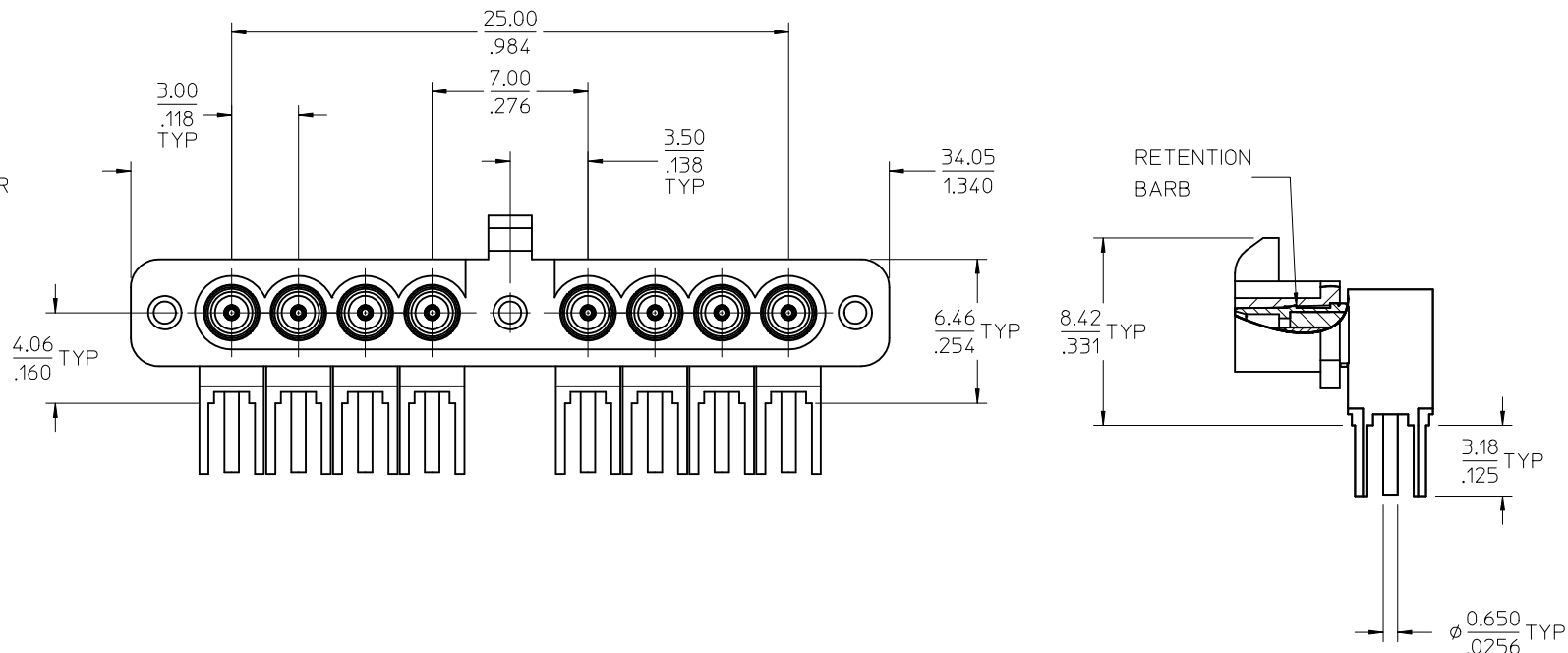

MATING FORCE WITH POPULATED  
BLOCK OF SSMCX PLUGS IS  
2.27-4.54 KG (5-10 LBS TYP)

UN-MATING FORCE WITH POPULATED  
BLOCK OF SSMCX PLUGS IS  
1.36-4.08 KG (3-9 LBS TYP)  
LATCH NOT ENGAGED

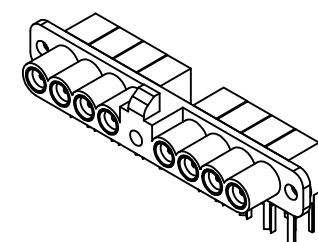
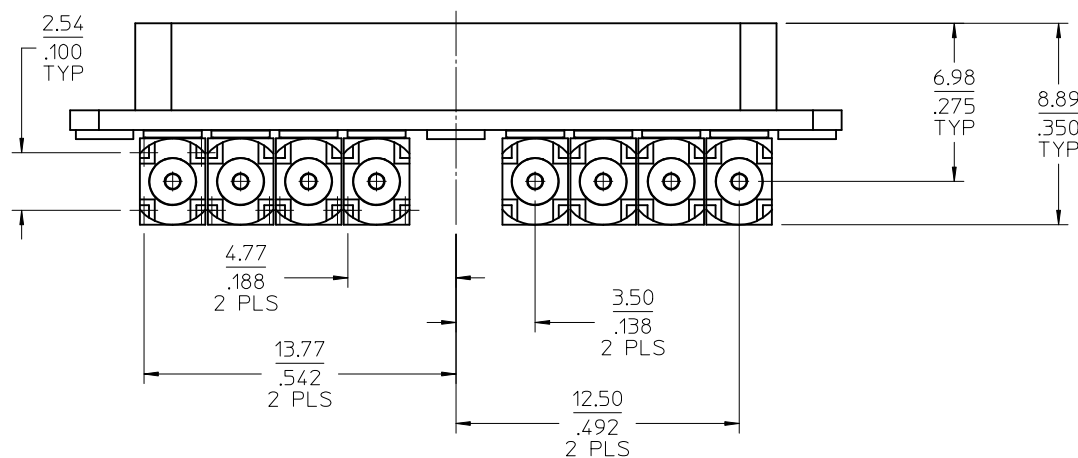

PART # 73358-0490

PS-89675-3600	ELEC/MECH PERFORMANCE
ES-73599-0009-0011	INTERFACE SSMCX JACK
SPECIFICATION	DESCRIPTION

CHG: ADDED SHEET 4  
FOR 73358-0492  
6 PORT VERSION.  
EC NO: URF2010-0385  
DRAWN: ROBERTSON 2009/12/30  
CHKD: SSS 2010/01/04  
APPR: JWIENER 2010/01/04

QUALITY SYMBOLS  
 = 0  
 = 0  
 DESCRIPTION

GENERAL TOLERANCES (UNLESS SPECIFIED)

	mm	INCH
4 PLACES	± .005	± .0005
3 PLACES	± .005	± .0005
2 PLACES	± .005	± .0005
1 PLACE	± .005	± .0005

ANGULAR ± 2 °

DRAFT WHERE APPLICABLE  
MUST REMAIN  
WITHIN DIMENSIONS

DIMENSION STYLE  
MM/IN

DRAWN BY	DATE
JDW	2009/09/22
CHECKED BY	DATE
SSS	2009/09/22
APPROVED BY	DATE
JDW	2009/09/22

MATERIAL NO.  
733580490

SIZE  
C

SCALE  
DESIGN UNITS  
INCH

THIRD ANGLE PROJECTION

TITLE  
SSMCX J RA PCB TALL  
MF GANG 4/6/8 50 OHM  
SSMCX-J/PCB, EWR-4206

MOLEX INCORPORATED

DOCUMENT NO.  
SD-73358-049

SHEET NO.  
1 OF 4

THIS DRAWING CONTAINS INFORMATION THAT IS PROPRIETARY TO MOLEX INCORPORATED AND SHOULD NOT BE USED WITHOUT WRITTEN PERMISSION

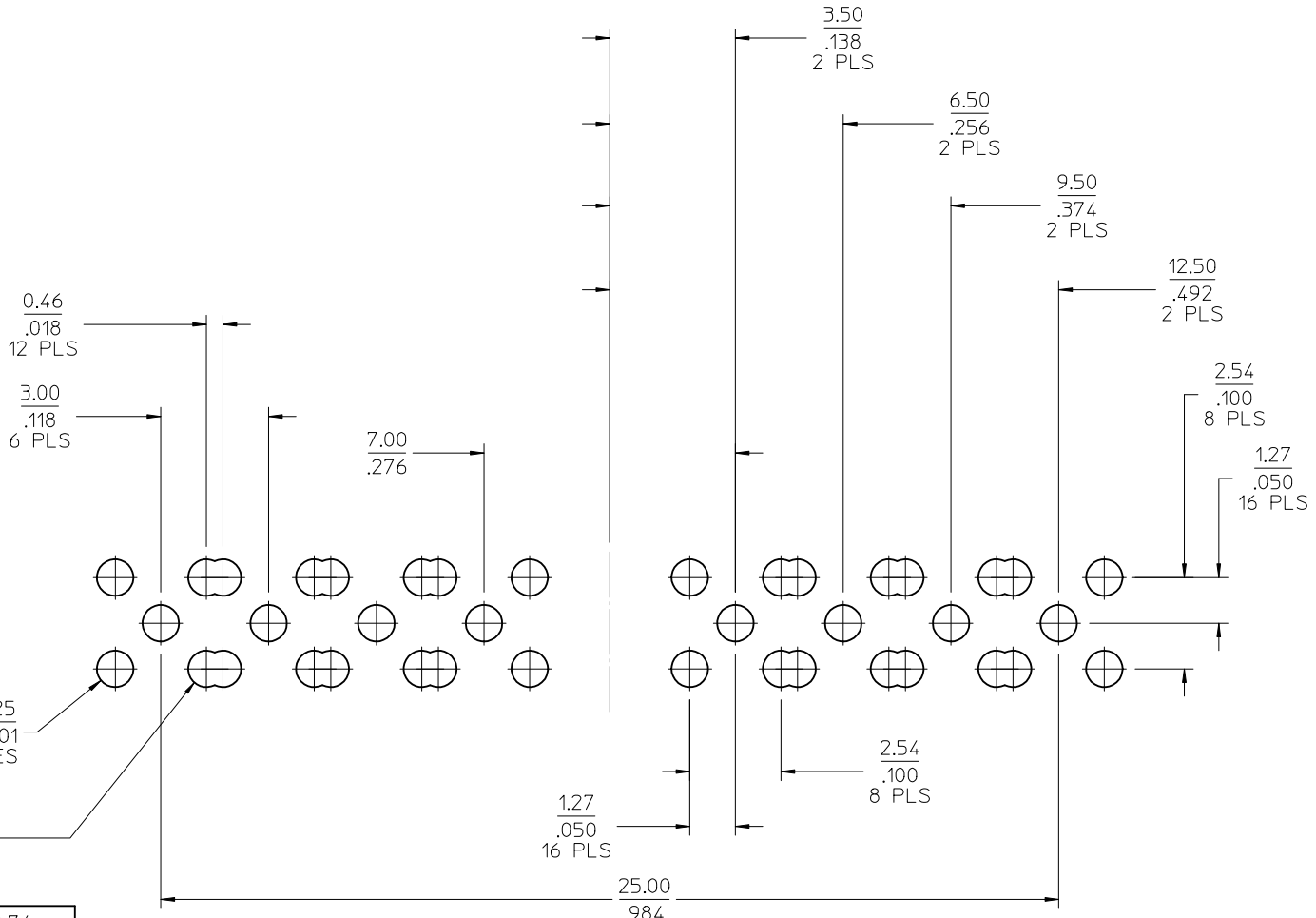

OPTIONAL HOLE PATTERN FOR OVERLAPPING HOLES

1.016 ± 0.025  
0.040 ± 0.001  
40 PLACES

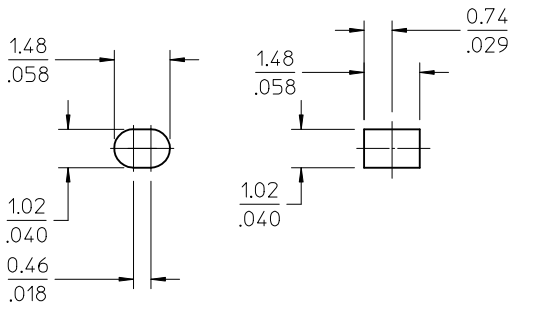

PCB HOLE PATTERN FOR 73358-0490

CHG: SEE SHEET 1. EC NO: URF2010-0385 DRWN: ROBERTSON 2009/12/30 CHKD: SSS 2010/01/04 APPR: JWIENER 2010/01/04	QUALITY SYMBOLS ▽=0 ▽=0	GENERAL TOLERANCES (UNLESS SPECIFIED)		DIMENSION STYLE MM/IN	SCALE INCH	DESIGN UNITS INCH	THIRD ANGLE PROJECTION		
		4 PLACES ± --- ± ---	3 PLACES ± --- ± ---	2 PLACES ± --- ± ---	1 PLACE ± --- ± ---	DRAWN BY JDW	DATE 2009/09/22	TITLE SSMCX J RA PCB TALL MF GANG 4/6/8 50 OHM SSMCX-J/PCB, EWR-4206	
		ANGULAR ± 2 °				CHECKED BY SSS	DATE 2009/09/22	APPROVED BY JDW	DATE 2009/09/22
		DRAFT WHERE APPLICABLE MUST REMAIN WITHIN DIMENSIONS		MATERIAL NO. 733580490	DOCUMENT NO. SD-73358-049	SHEET NO. 2 OF 4			

MATERIALS AND FINISHES

SEE SHEET 1

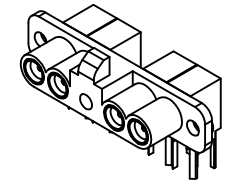
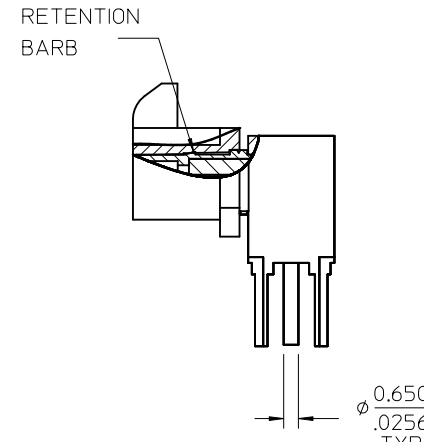
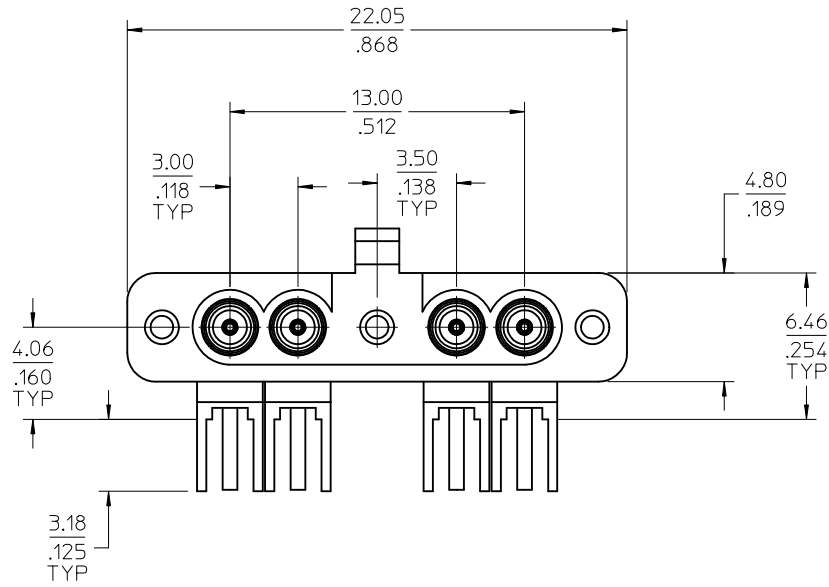

MATING FORCE WITH POPULATED BLOCK OF SSMCX PLUGS IS 1.13-2.27 KG (2.5-5 LBS TYP)

UN-MATING FORCE WITH POPULATED BLOCK OF SSMCX PLUGS IS 0.68-2.04 KG (1.5-4.5 LBS TYP) LATCH NOT ENGAGED

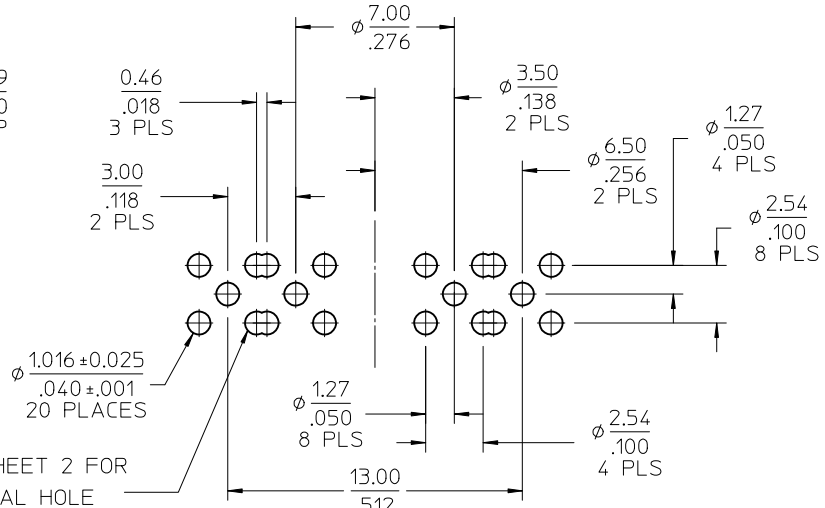
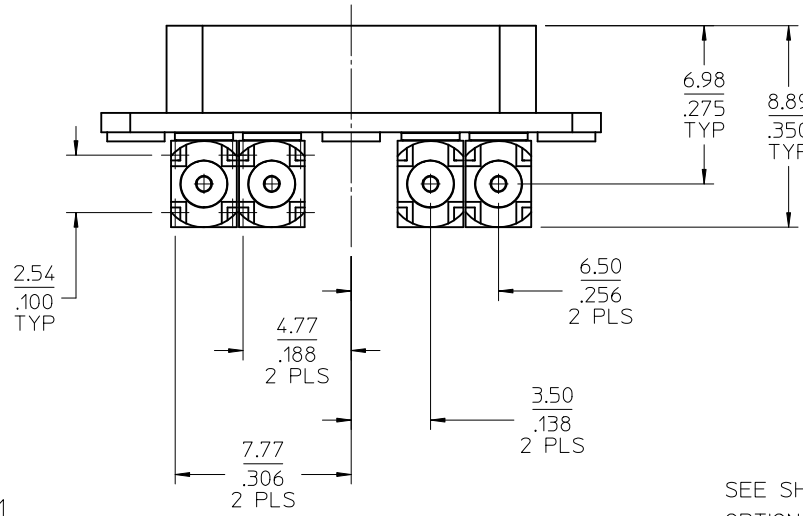

PART # 73358-0491

SEE SHEET 2 FOR OPTIONAL HOLE PATTERN FOR OVERLAPPING HOLES

PCB HOLE PATTERN FOR 73358-0491

SEE SHEET 1 EC NO: URF2010-0385 DRWN:ROBERTSON 2009/12/30 CHKD:SSS 2010/01/04 APPR:JWIENER 2010/01/04	QUALITY SYMBOLS ▽=0 ▽=0	GENERAL TOLERANCES (UNLESS SPECIFIED)		DIMENSION STYLE MM/IN	SCALE INCH	DESIGN UNITS INCH	THIRD ANGLE PROJECTION
		4 PLACES ± --- ± --- 3 PLACES ± --- ± --- 2 PLACES ± --- ± --- 1 PLACE ± --- ± ---	mm INCH	DRAWN BY JDW	DATE 2009/09/22	TITLE SSMCX J RA PCB TALL MF GANG 4/6/8 50 OHM SSMCX-J/PCB, EWR-4206	MOLEX INCORPORATED
A1	DRAFT WHERE APPLICABLE MUST REMAIN WITHIN DIMENSIONS	MATERIAL NO. 733580491	DATE 2009/09/22	APPROVED BY JDW	DOCUMENT NO. SD-73358-049	SHEET NO. 3 OF 4	THIS DRAWING CONTAINS INFORMATION THAT IS PROPRIETARY TO MOLEX INCORPORATED AND SHOULD NOT BE USED WITHOUT WRITTEN PERMISSION

MATERIALS AND FINISHES

SEE SHEET 1

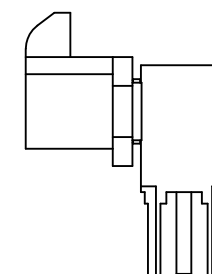
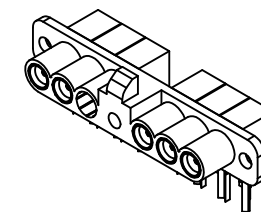
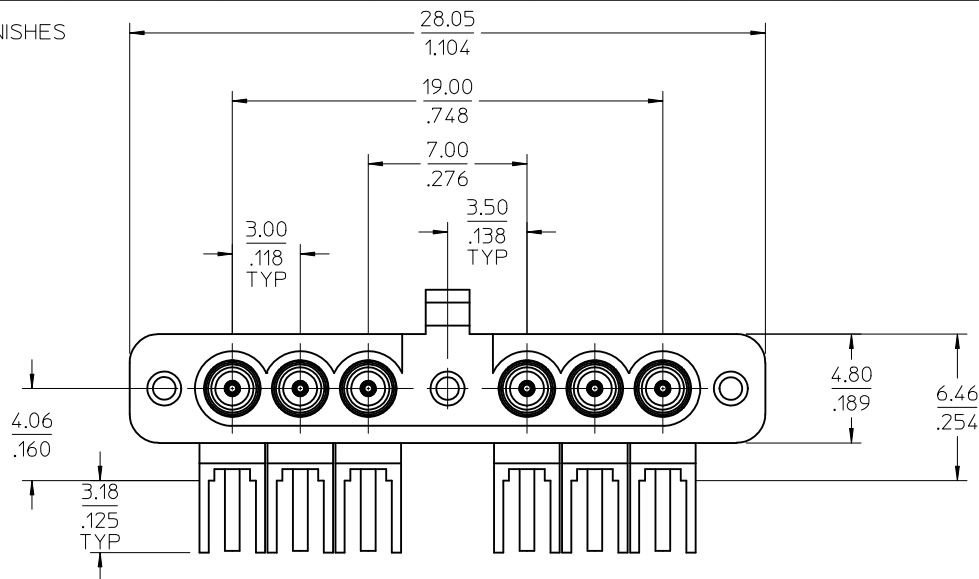

MATING FORCE WITH POPULATED BLOCK OF SSMCX PLUGS IS 2.04-340 KG (4.5-7.5 LBS TYP)

UN-MATING FORCE WITH POPULATED BLOCK OF SSMCX PLUGS IS 1.35-2.27 KG (3-5 LBS TYP) LATCH NOT ENGAGED

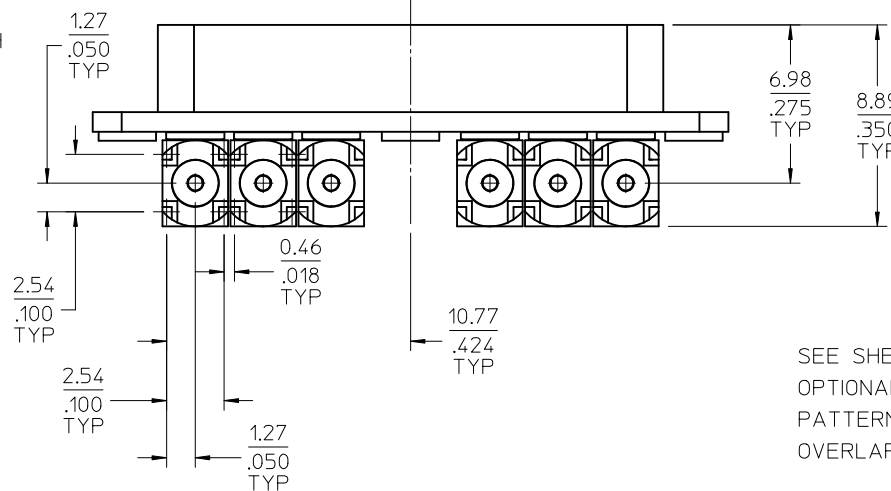

SEE SHEET 2 FOR OPTIONAL HOLE PATTERN FOR OVERLAPPING HOLES

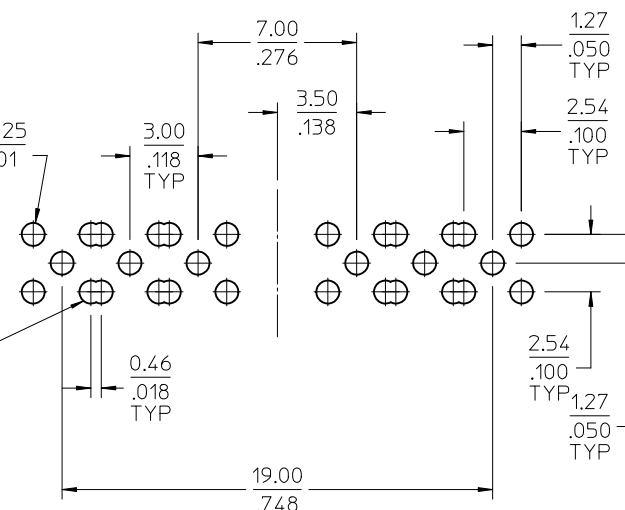

POCB HOLE PATTERN  
73358-0492

PART # 73358-0492

CHG: SEE SHEET 1.	QUALITY SYMBOLS
EC NO: URF2010-0385	▽=0
DRWN:ROBERTSON 2009/12/30	▽=0
CHKD:SSS 2010/01/04	
APPR:JWIENER 2010/01/04	
REV	DESCRIPTION
A1	

GENERAL TOLERANCES (UNLESS SPECIFIED)
4 PLACES ± --- ± ---
3 PLACES ± --- ± ---
2 PLACES ± --- ± ---
1 PLACE ± --- ± ---
ANGULAR ± 2 °
DRAFT WHERE APPLICABLE MUST REMAIN WITHIN DIMENSIONS

DIMENSION STYLE		SCALE	DESIGN UNITS	THIRD ANGLE PROJECTION
MM/IN		INCH	INCH	
DRAWN BY	DATE	TITLE		
JDW	2009/09/22	SSMCX J RA PCB TALL		
CHECKED BY	DATE	MF GANG 4/6/8 50 OHM		
SSS	2009/09/22	SSMCX-J/PCB, EWR-4206		
APPROVED BY	DATE	MOLEX INCORPORATED		
JDW	2009/09/22			
MATERIAL NO.	DOCUMENT NO.	SHEET NO.		
733580462	SD-73358-049	4 OF 4		
SIZE	THIS DRAWING CONTAINS INFORMATION THAT IS PROPRIETARY TO MOLEX INCORPORATED AND SHOULD NOT BE USED WITHOUT WRITTEN PERMISSION			
C				