

# Customer Information Sheet

DRAWING No.: M40-600XX46R

SHEET 3 OF 4

IF IN DOUBT - ASK

©

NOT TO SCALE

THIRD ANGLE PROJECTION

ALL DIMENSIONS IN mm

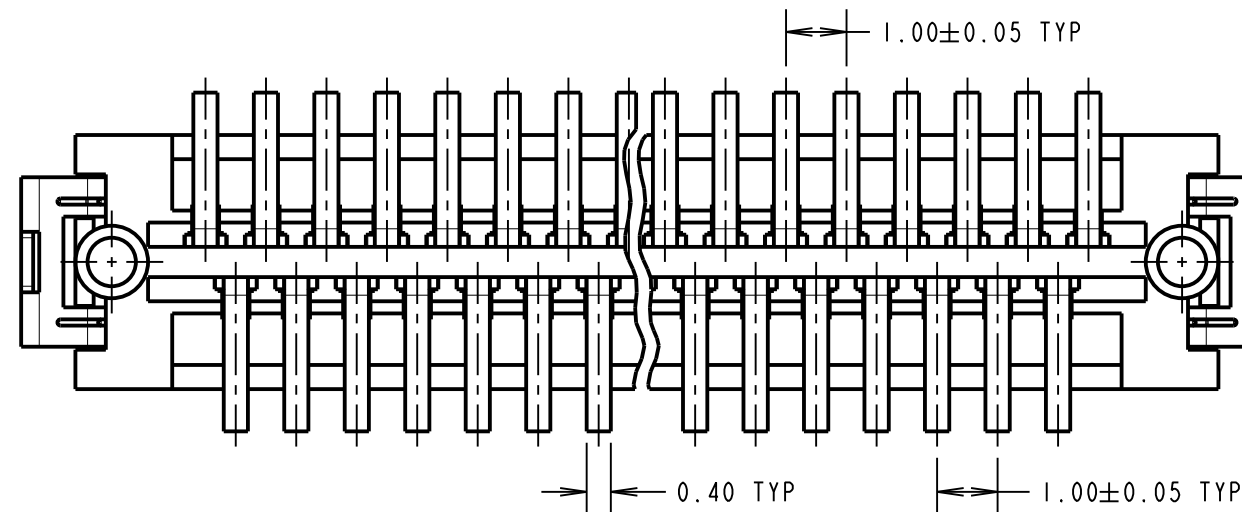
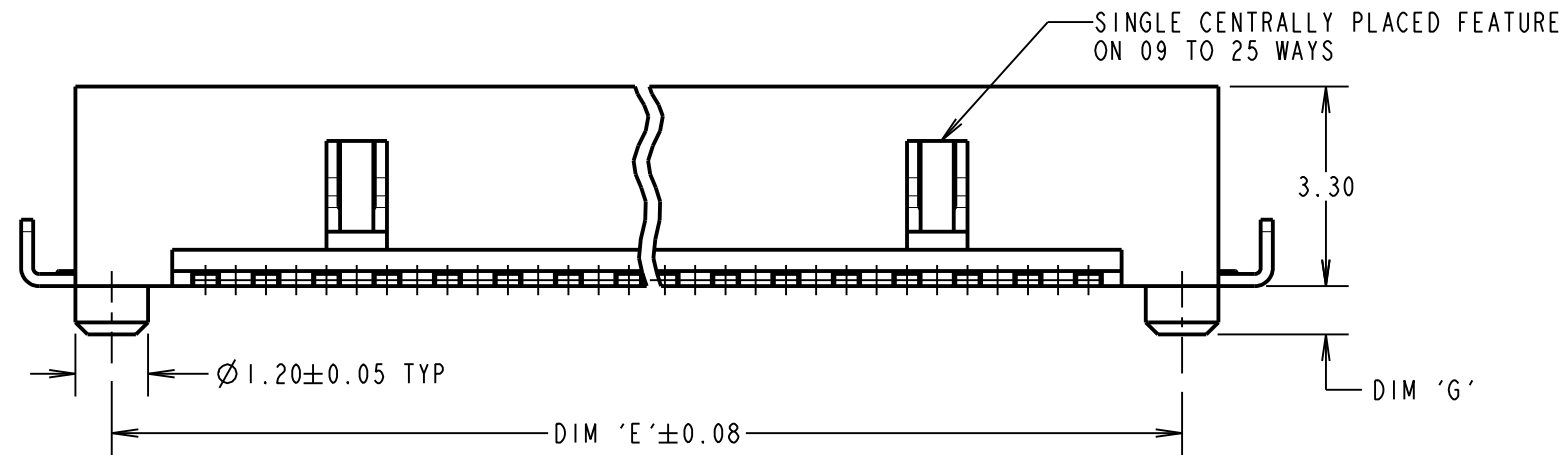
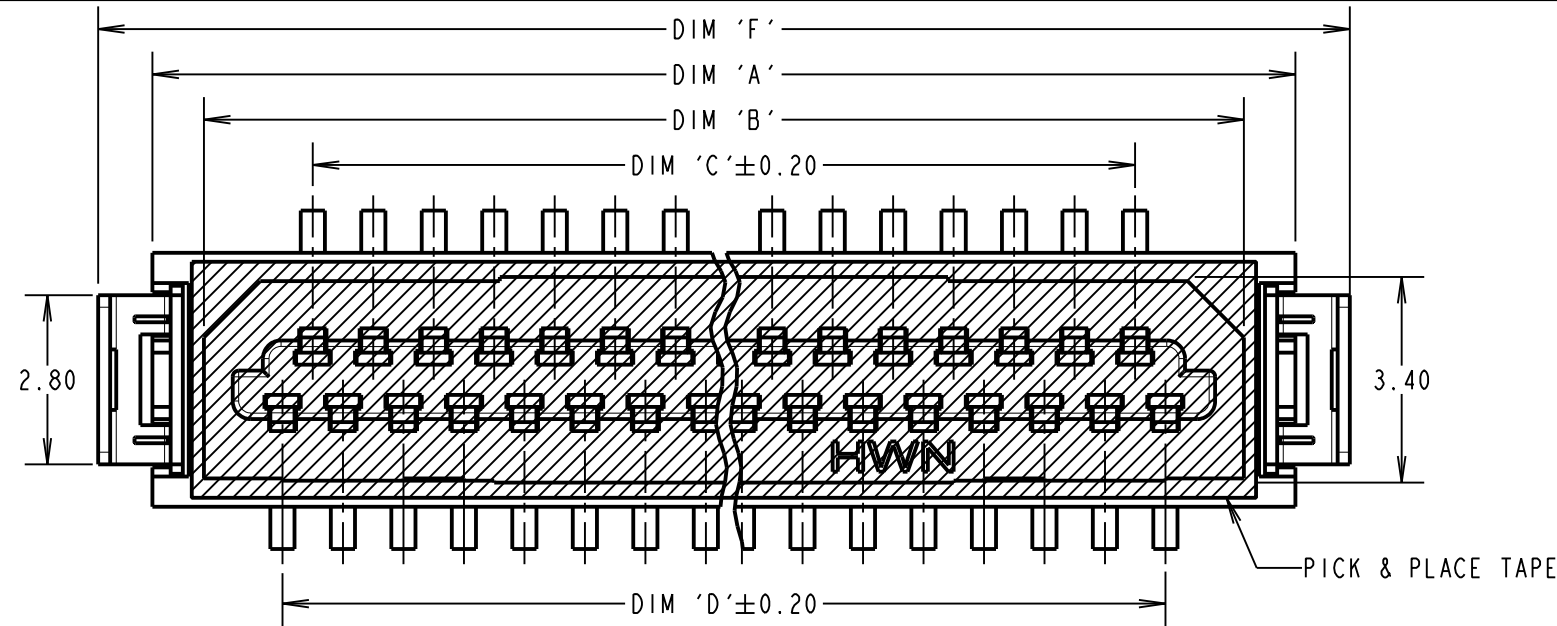

PART No.	No. OF CONTACTS	DIM 'A'	DIM 'B'	DIM 'C'	DIM 'D'	DIM 'E'	DIM 'F'	DIM 'G'	DIM 'H'
M40-6000946R	9	8.30	6.60	3.00	4.00	7.10	10.10	1.00	1.84 <sup>+0.10</sup> -0.00
M40-6001546R	15	11.30	9.60	6.00	7.00	10.10	13.10		
M40-6002146R	21	14.30	12.60	9.00	10.00	13.10	16.10		
M40-6002546R	25	16.30	14.60	11.00	12.00	15.10	18.10		
M40-6003146R	31	19.30	17.60	14.00	15.00	18.10	21.10	0.80	3.00 <sup>+0.00</sup> -0.10
M40-6004146R	41	24.30	22.60	19.00	20.00	23.10	26.10		
M40-6005146R	51	29.30	27.60	24.00	25.00	28.10	31.10		

**SPECIFICATIONS:**

**MATERIAL:**

MOULDING = LCP, NATURAL, UL94V-0

CONTACTS = PHOSPHOR BRONZE

RETAINERS = BRASS

FINISH = 2.03µm MIN 100% TIN, OVER 1.27µm MIN NICKEL

**ELECTRICAL:**

CURRENT RATING = 0.5A

VOLTAGE RATING = 250V AC

DIELECTRIC STRENGTH = 250V AC FOR 1 MINUTE

INSULATION RESISTANCE = 500 MEGAOHMS MIN (100V DC)

CONTACT RESISTANCE = 50 MILLIOHMS MAX (0.1A DC)

**MECHANICAL:**

DURABILITY = 30 CYCLES MIN

**ENVIRONMENTAL:**

TEMPERATURE RANGE = -20°C TO +125°C

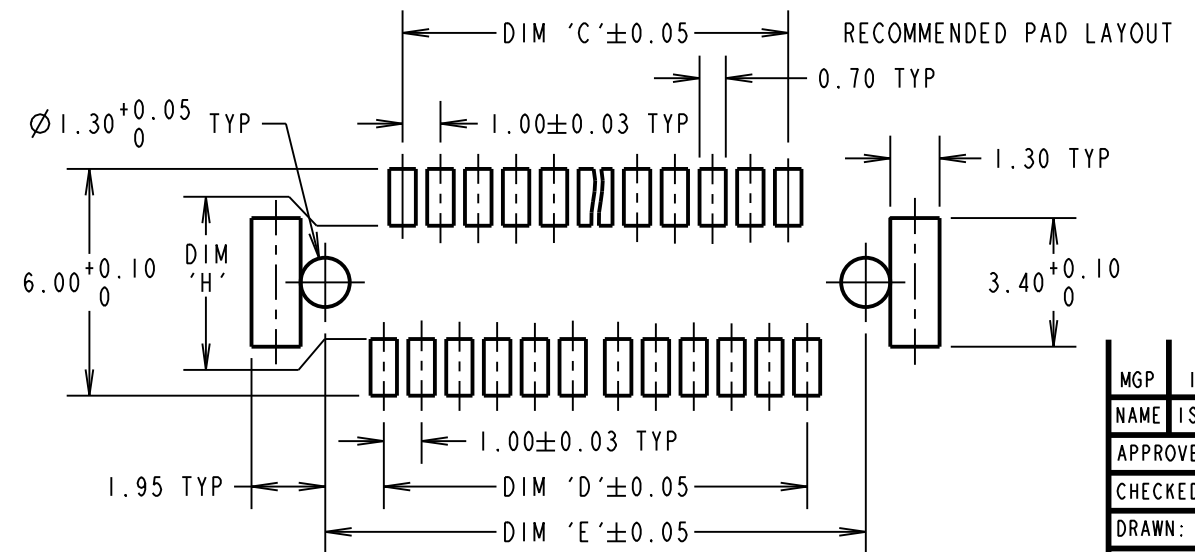
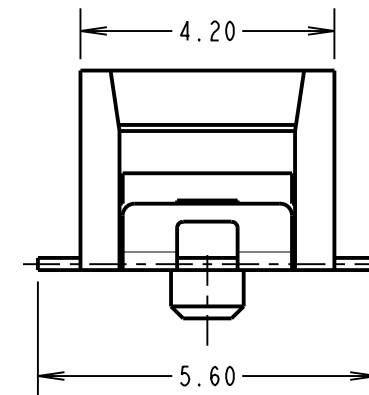

**NOTES:**

- MATES WITH M40-620XX46 TO GIVE 4.3mm BOARD TO BOARD HEIGHT.
- ALL TOLERANCES ARE ±0.25 UNLESS OTHERWISE STATED.
- SUPPLIED WITH HIGH TEMPERATURE TAPE FOR PICK & PLACE.

MGP	13	14.08.13	21443
NAME	ISS.	DATE	C/NOTE
APPROVED: MGP			
CHECKED: RP			
DRAWN: R.ADDE			
CUSTOMER REF.:			
ASSEMBLY DRG:			

ORDER CODE: **M40-600XX46R**

No. OF CONTACTS: 09, 15, 21, 25, 31, 41, 51

FINISH: 46 = 100% TIN

**HARWIN**

www.harwin.com  
technical@harwin.com

THIS DRAWING AND ANY INFORMATION OR DESCRIPTIVE MATTER SET OUT HEREON ARE CONFIDENTIAL AND COPYRIGHT PROPERTY OF THE HARWIN GROUP AND MUST NOT BE DISCLOSED, LOANED, COPIED OR USED FOR MANUFACTURING, TENDERING OR FOR ANY OTHER PURPOSE WITHOUT THEIR WRITTEN PERMISSION.

**TOLERANCES**  
X = ±1mm  
X.X = ±0.50mm  
X.XX = ±0.10mm  
X.XXX = ±0.01mm  
ANGLES = ±5°  
UNLESS STATED

**MATERIAL:** SEE ABOVE

**FINISH:** SEE ABOVE

**S/AREA:** mm<sup>2</sup>

**TITLE:** 1.00mm PITCH SMT PLUG CONNECTOR (WITH PICK & PLACE, TAPE & REELED)

**DRAWING NUMBER:** **M40-600XX46R**

SHT 3 OF 4

# Customer Information Sheet

DRAWING No.: M40-600XX46R

SHEET 4 OF 4

IF IN DOUBT - ASK

©

NOT TO SCALE

THIRD ANGLE PROJECTION

ALL DIMENSIONS IN mm

ASSEMBLY PART No.	DIM 'A'	DIM 'B'	DIM 'C'	DIM 'D'	DIM 'E'	DIM 'F'	DIM 'G'	DIM 'H'
M40-6000946R	3.00	4.00	7.10	11.50 ±0.15	24.00	4.85	1.84	+0.10 -0.00
M40-6001546R	6.00	7.00	10.10					
M40-6002146R	9.00	10.00	13.10	14.20	28.40	32.00	4.65	3.00
M40-6002546R	11.00	12.00	15.10					
M40-6003146R	14.00	15.00	18.10					
M40-6004146R	19.00	20.00	23.10	20.02 ±0.15	40.40	44.00	4.65	+0.00 -0.10
M40-6005146R	24.00	25.00	28.10					

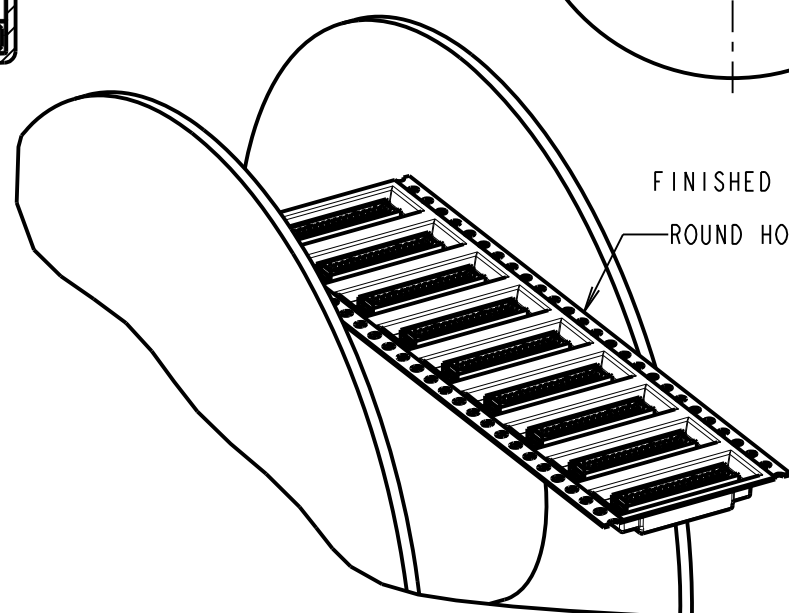
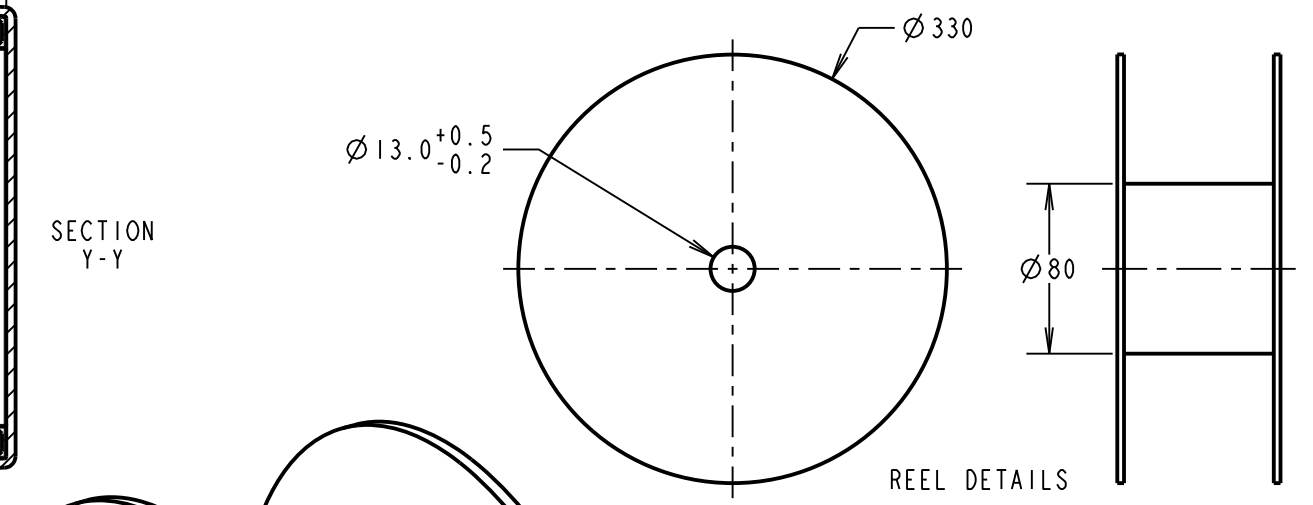
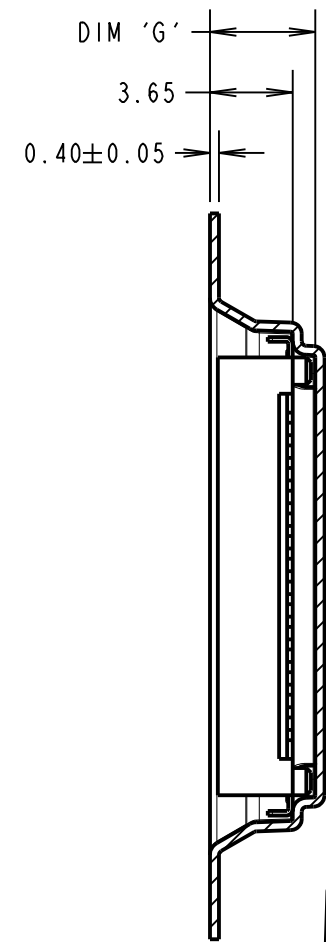
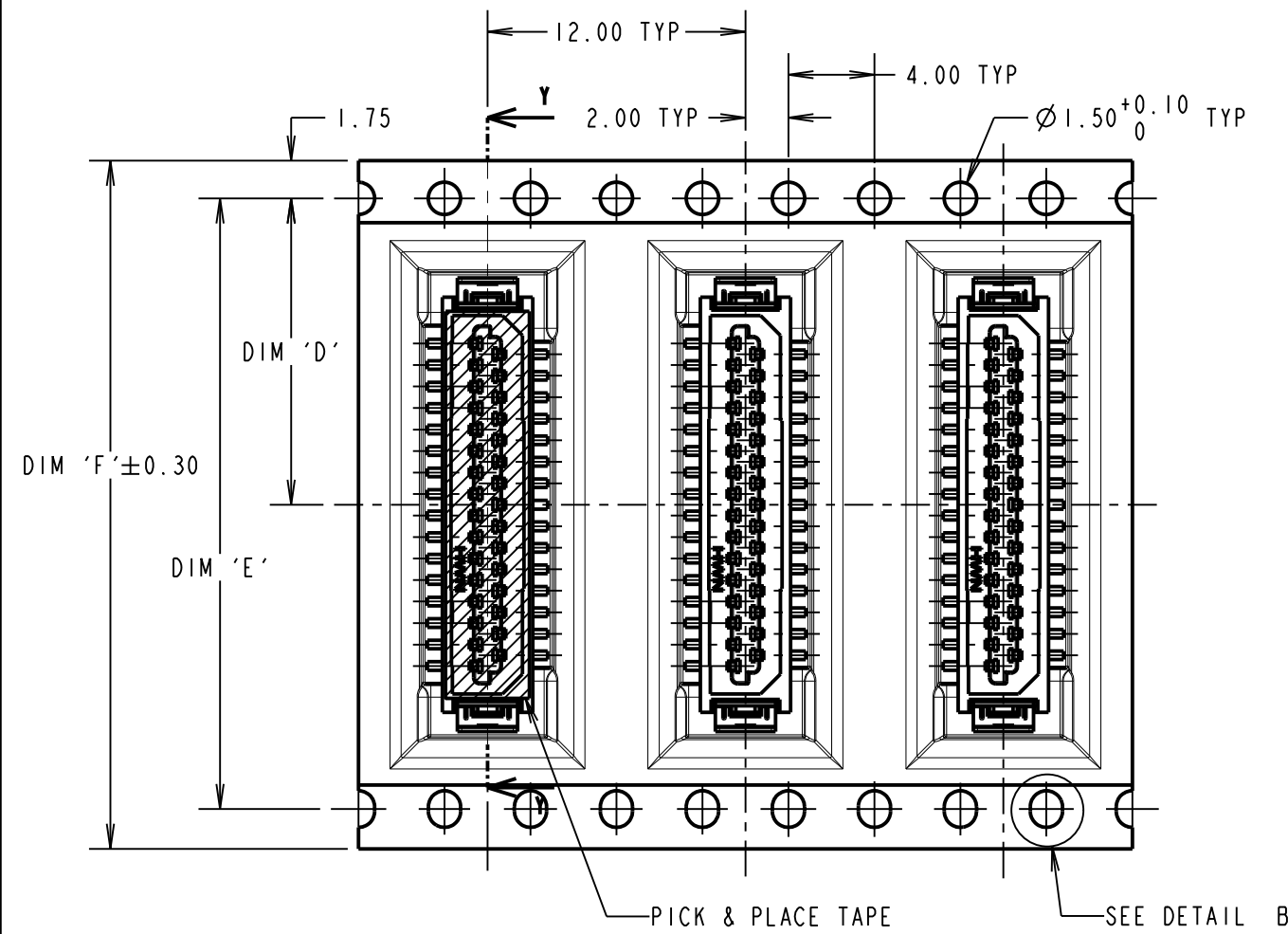
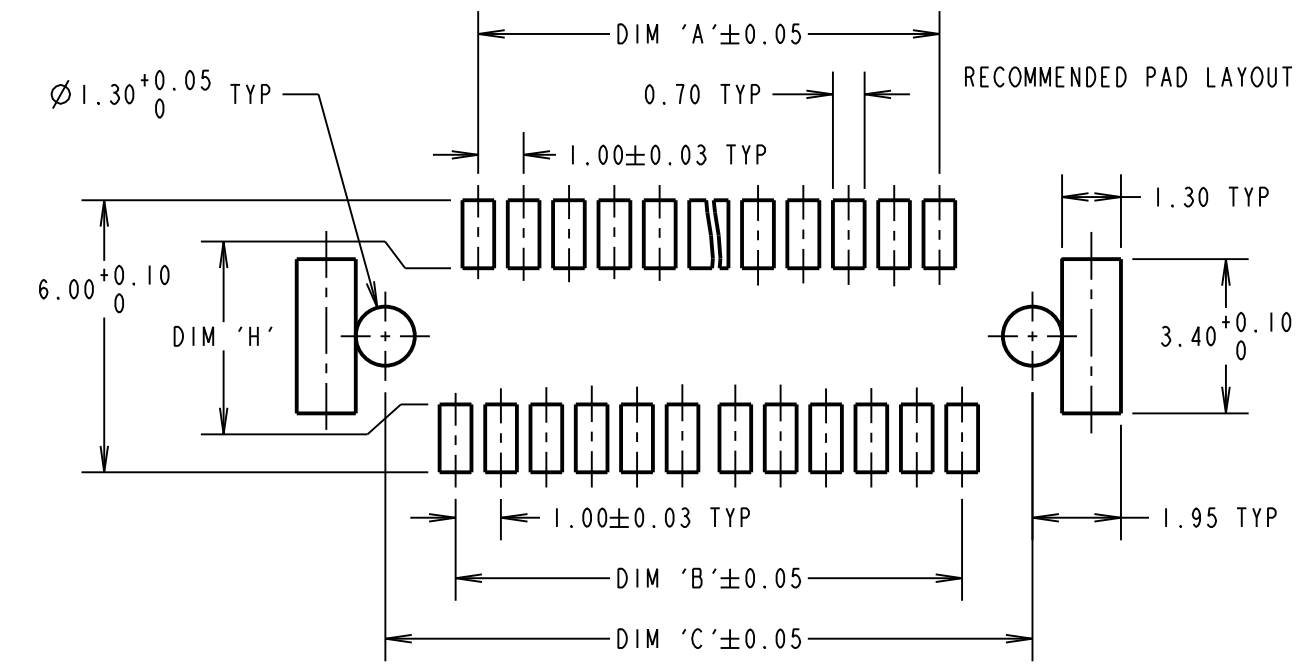

ORDER CODE:  
**M40-600XX46R**

No. OF CONTACTS  
09, 15, 21, 25, 31,  
41, 51

FINISH:  
46 = 100% TIN

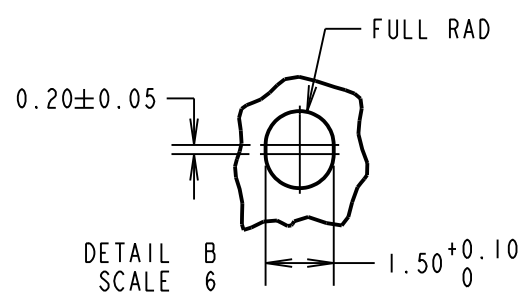

MGP	13	14.08.18	21443
NAME	ISS.	DATE	C/NOTE
APPROVED: MGP			
CHECKED: RP			
DRAWN: R. ADDE			
CUSTOMER REF.:			
ASSEMBLY DRG:			

NOTES:  
1. FOR CONNECTOR DIMENSIONS SEE SHEET 3.  
2. TAPE AND REELING IN ACCORDANCE WITH ELECTRONIC INDUSTRIES ASSOCIATION EIA-481.  
3. QUANTITY PER REEL = 1000 COMPONENTS.

<p>www.harwin.com technical@harwin.com</p>	<p>THIS DRAWING AND ANY INFORMATION OR DESCRIPTIVE MATTER SET OUT HEREON ARE CONFIDENTIAL AND COPYRIGHT PROPERTY OF THE HARWIN GROUP AND MUST NOT BE DISCLOSED, LOANED, COPIED OR USED FOR MANUFACTURING, TENDERING OR FOR ANY OTHER PURPOSE WITHOUT THEIR WRITTEN PERMISSION.</p>	<p>TOLERANCES</p> <p>X. = ±1mm X.X = ±0.50mm X.XX = ±0.10mm X.XXX = ±0.01mm</p> <p>ANGLES = ±5° UNLESS STATED</p>	<p>MATERIAL:</p> <p>SEE ABOVE</p>	<p>TITLE: 1.00mm PITCH SMT PLUG CONNECTOR (WITH PICK &amp; PLACE, TAPE &amp; REELED)</p>
		<p>FINISH: SEE ABOVE</p> <p>S/AREA: mm<sup>2</sup></p>	<p>DRAWING NUMBER:</p> <p><b>M40-600XX46R</b></p>	<p>SHT 4 OF 4</p>