

INVERTED PROFILE MAGNETIC JACK
FAST ETHERNET W/LED

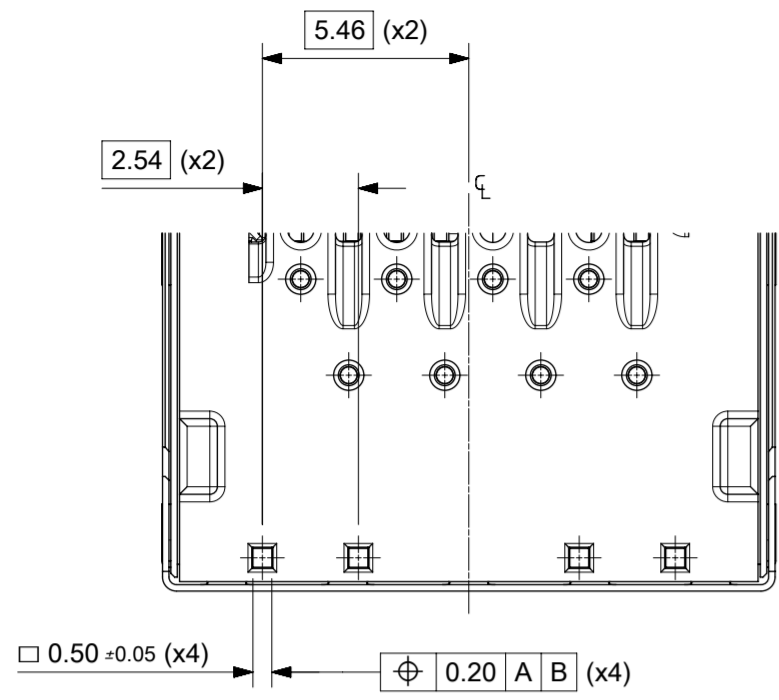

DETAIL A
SCALE 5:1

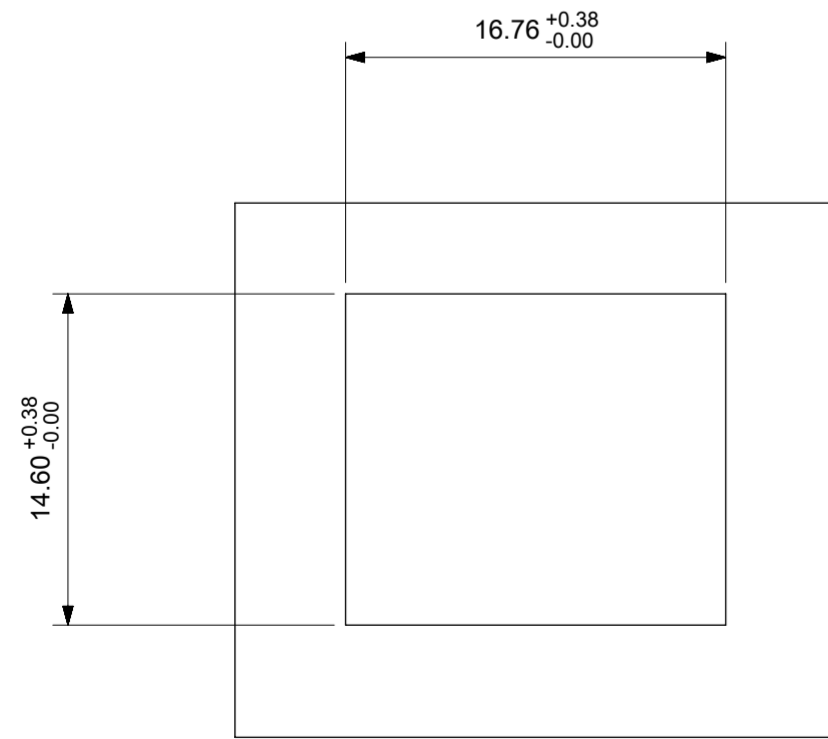

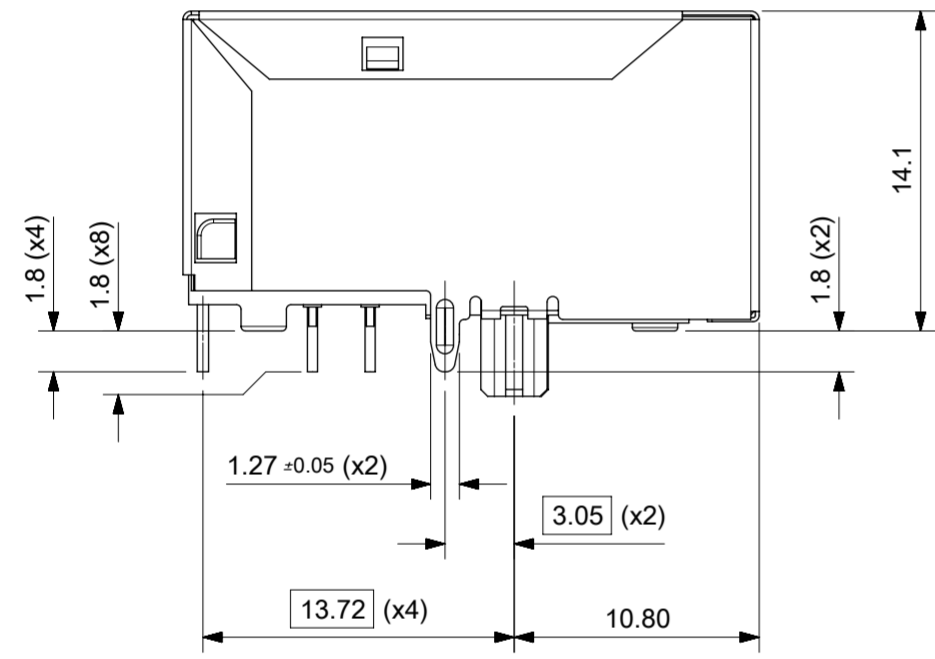

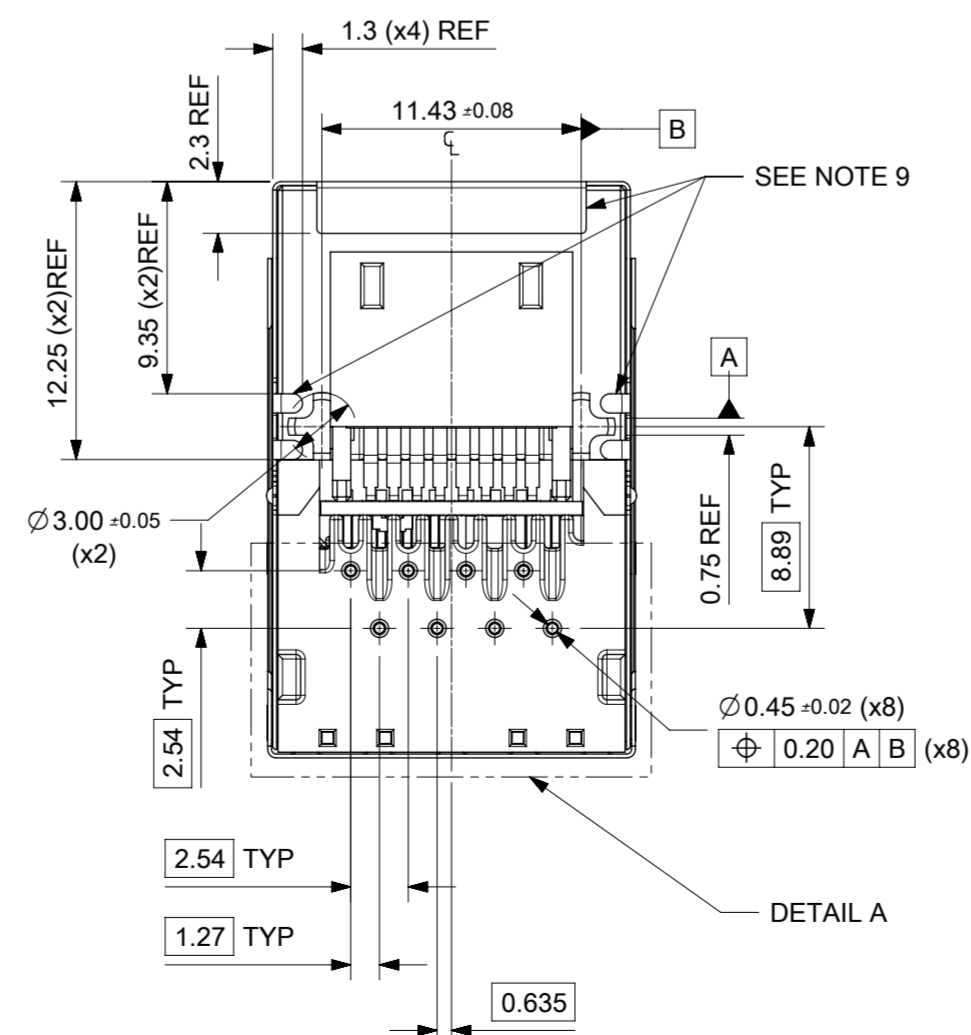
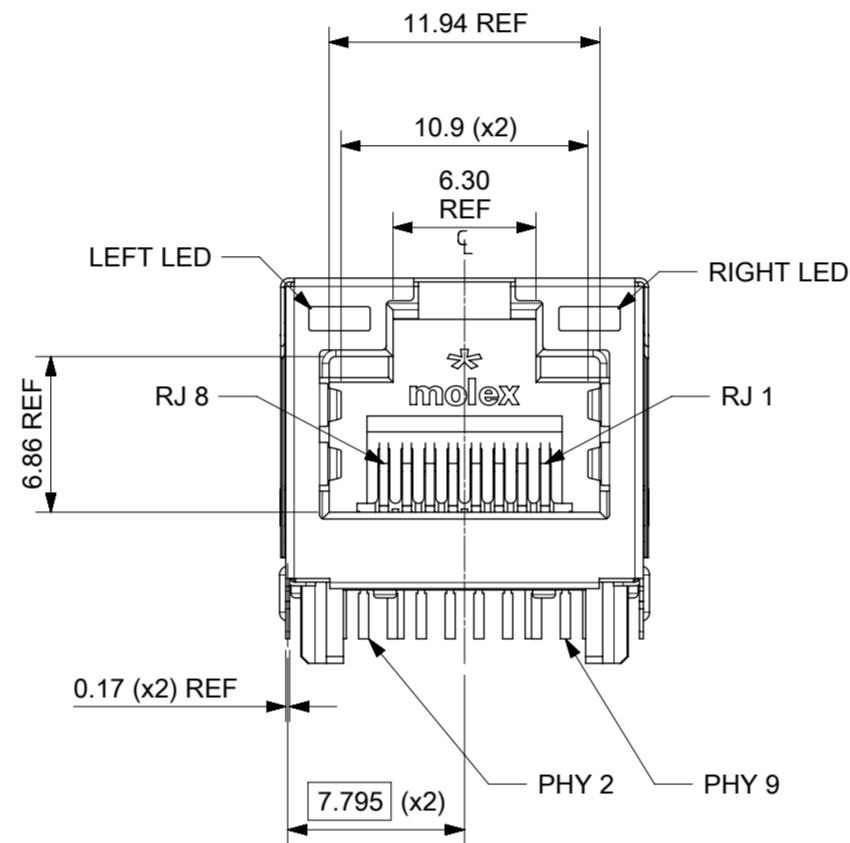
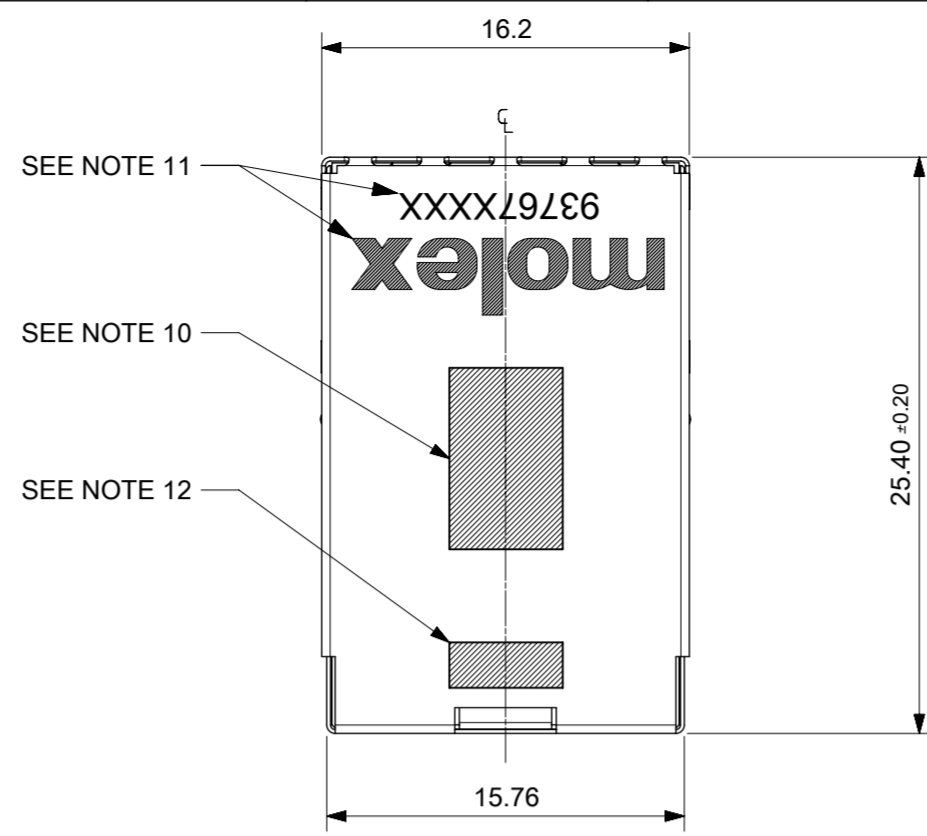
SUGGESTED PANEL OUT-OUT

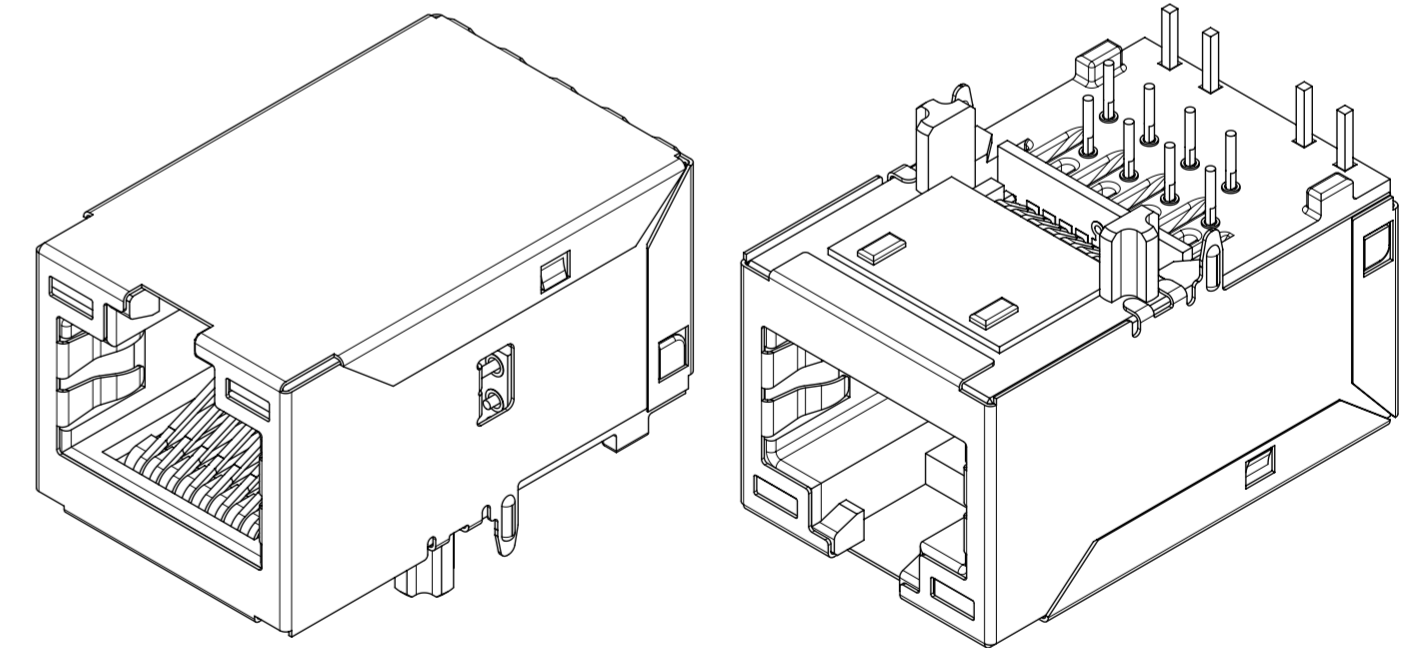

NOTES:

- 1 - SHIELD MATERIAL: 0.17MM THICK BRASS PRE-PLATED WITH NICKEL.
SOLDER TABS POST DIPPED WITH MIN. 1.27µm TIN
- 2 - HOUSING MATERIAL: LCP, BLACK, UL 94V-0.
- 3 - TERMINALS MATERIAL: PHOSPHOR BRONZE.
RJ45 CONTACT PLATING: BASE NICKEL, GOLD FLASH OVER PALLADIUM NICKEL.
PHY SOLDER TAILS: COPPER ALLOY REFER TO 934620001 PSP.
- 4 - MATING INTERFACE ACCORDING TO IEC 60603-7 & TIA-1096-A.
- 5 - PRODUCT SPECIFICATION: 934620001 PSP.
- 6 - PACKAGING SPECIFICATION: 934620002 PSK TAPE & REEL.
TAPE AND REEL DRAWING NUMBER: 990449058 PSDK
- 7 - STAND OFF TO SYSTEM BOARD 0.30 mm MIN.
- 8 - RECOMMENDED PCB THICKNESS: 1.57 mm REF.
- 9 - SHIELD: AVOID ROUTING TRACES
OR PLACING ANY VIAS BELOW THESE AREAS.
- 10 - AREA FOR PICK AND PLACE: 5.0 mm X 8.0 mm.
- 11 - INSCRIPTION MARKED BY LASER:
1st : MOLEX
2nd : P/N (SEE BOM)
- 12 - INSCRIPTION MARKED BY LASER:
DATE CODE(DAY/WEEK/YEAR)



THIS DRAWING CONTAINS INFORMATION THAT IS PROPRIETARY TO MOLEX ELECTRONIC TECHNOLOGIES, LLC AND SHOULD NOT BE USED WITHOUT WRITTEN PERMISSION													
DIMENSION UNITS mm		SCALE 3:1		CURRENT REV DESC: UPDATED TITLE									
GENERAL TOLERANCES (UNLESS SPECIFIED)				 1" MXMAG 4 CORE FE IND REFLOW CAPABLE									
ANGULAR TOL ± 2.0°		4 PLACES ±								EC NO: 604273		2018/07/26	
3 PLACES ±		2 PLACES ± 0.1								DRWN: DSHEA		2018/08/15	
1 PLACE ± 0.2		0 PLACES ±								CHK'D: SMCGREEVY		2019/09/25	
DRAFT WHERE APPLICABLE MUST REMAIN WITHIN DIMENSIONS		THIRD ANGLE PROJECTION								DRAWING		SERIES	
PRODUCT CUSTOMER DRAWING		INITIAL REVISION:		APPR: DBYRNES		2016/07/01		DOCUMENT NUMBER					
1 OF 3		A2-SIZE		93767		2016/09/23		937670002					
MATERIAL NUMBER		CUSTOMER		SHEET NUMBER		DOC TYPE		DOC PART					
SEE TABLE ON SHEET 2		GENERAL MARKET		1 OF 3		PSD		000					

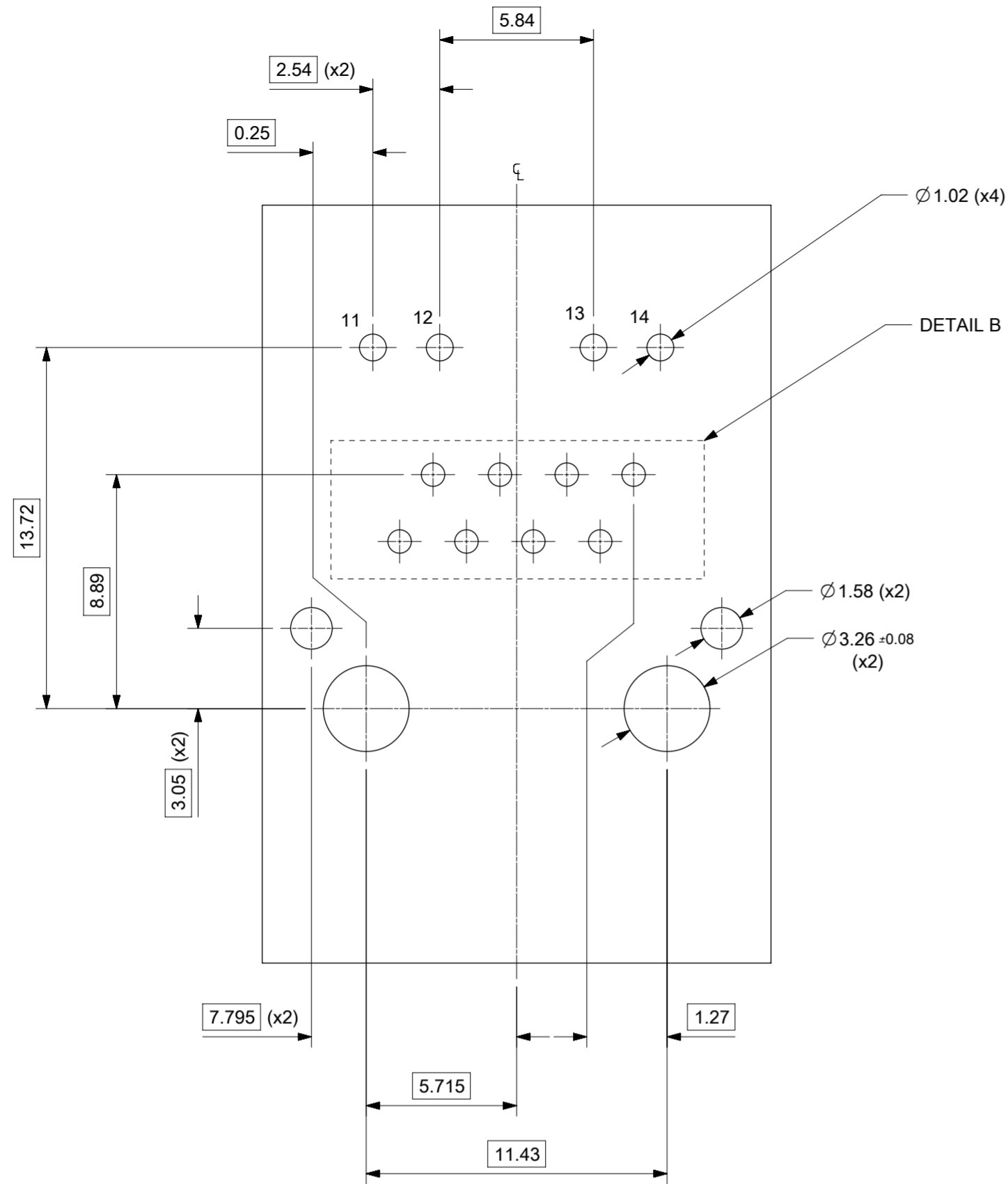

SUGGESTED BOARD LAYOUT
FAST ETHERNET
VIEW FROM COMPONENT SIDE
ALL DIMS ARE REFERENCE

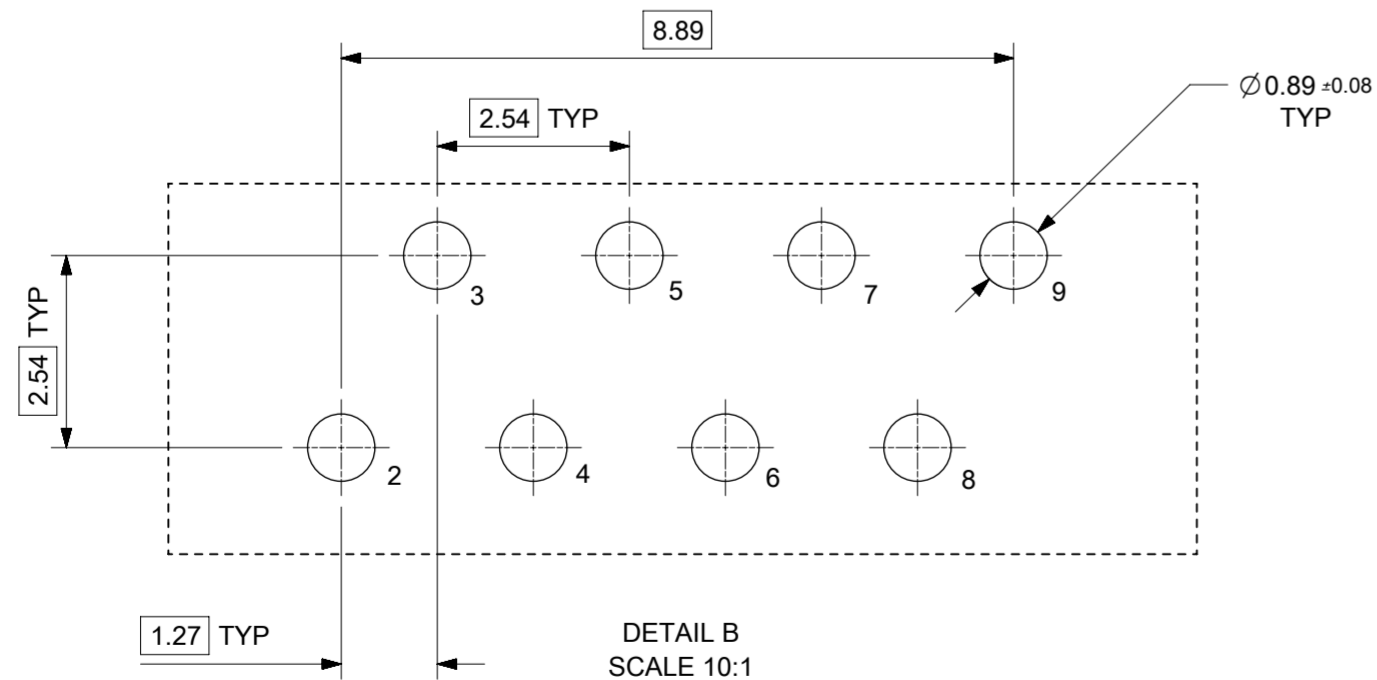

PIN CONFIGURATION
FOR FAST ETHERNET

PART NUMBER	LEFT LED	RIGHT LED
937675126	GREEN	YELLOW

THIS DRAWING CONTAINS INFORMATION THAT IS PROPRIETARY TO MOLEX ELECTRONIC TECHNOLOGIES, LLC AND SHOULD NOT BE USED WITHOUT WRITTEN PERMISSION									
DIMENSION UNITS	SCALE	CURRENT REV DESC: UPDATED TITLE							
mm	5:1								
GENERAL TOLERANCES (UNLESS SPECIFIED)					1" MXMAG 4 CORE FE IND REFLOW CAPABLE				
ANGULAR TOL	± 2.0°	EC NO: 604273							
4 PLACES	±	DRWN: DSHEA 2018/07/26							
3 PLACES	±	CHK'D: SMCGREEVY 2018/08/15							
2 PLACES	± 0.1	APPR: DBYRNES 2019/09/25							
1 PLACE	± 0.2	INITIAL REVISION:			PRODUCT CUSTOMER DRAWING				
0 PLACES	±	DRWN: DSHEA 2016/07/01			DOCUMENT NUMBER		DOC TYPE	DOC PART	REVISION
		APPR: STGRIFFIN 2016/09/23			937670002		PSD	000	C
DRAFT WHERE APPLICABLE MUST REMAIN WITHIN DIMENSIONS	THIRD ANGLE PROJECTION	DRAWING	SERIES	MATERIAL NUMBER	CUSTOMER		SHEET NUMBER		
		A2-SIZE	93767	SEE TABLE ON SHEET 2	GENERAL MARKET		2 OF 3		

DOCUMENT STATUS	P1	RELEASE DATE	2019/09/25	12:10:11
-----------------	----	--------------	------------	----------

RJ-45 CONTACTS

WIRE-SIDE / RJ-45

ETHERNET MAGNETICS

PHY-SIDE / PCB SIDE

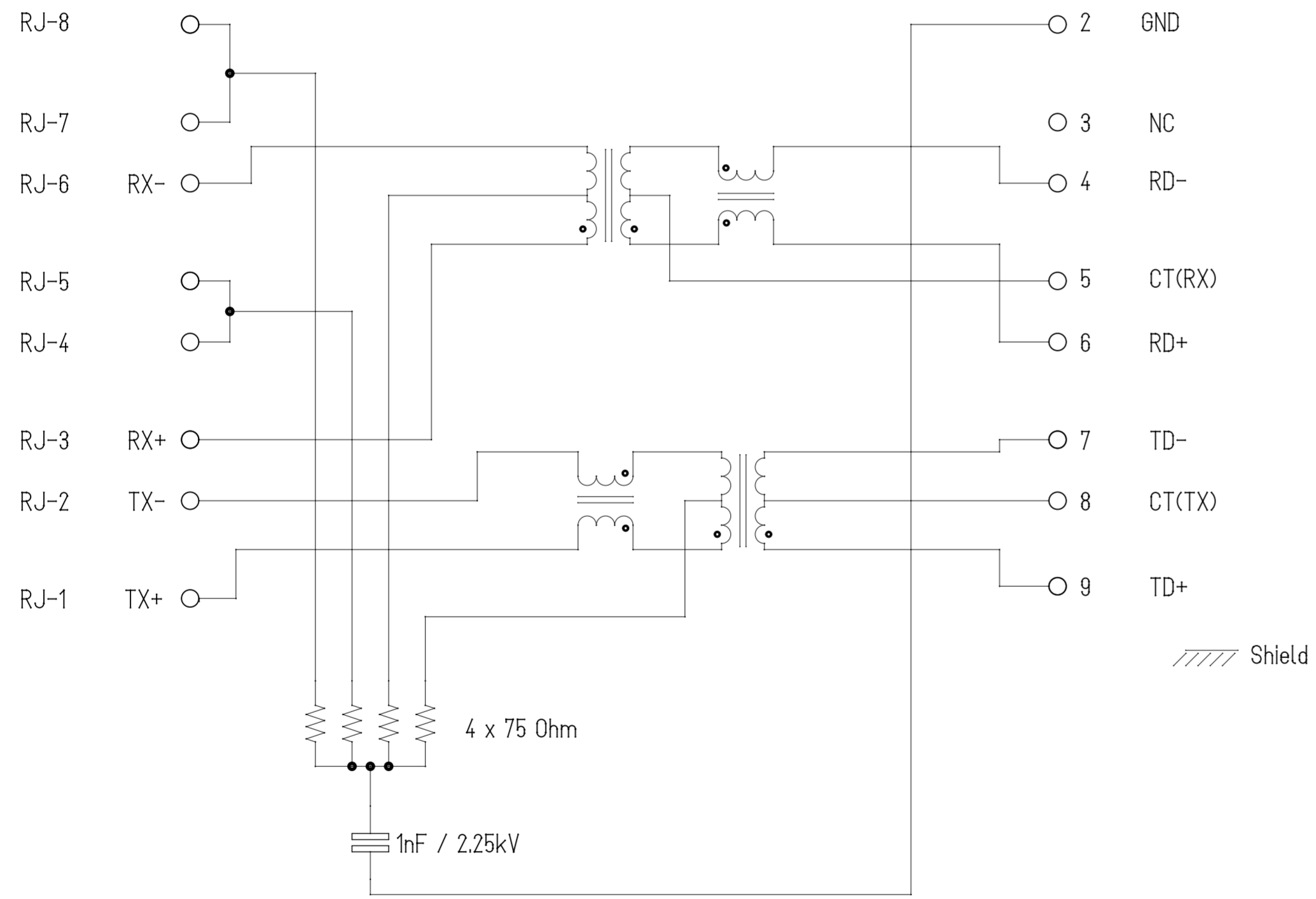

Description	Value	
OCL @100 kHz, 0.1 V, 8 mA DC bias (-40°C TO +85°C)	350 μH min.	
Turns ratio	1CT:1CT	
Transmission characteristics @ 25°C, all four pairs		
Insertion Loss		
Frequency f, (MHz)	Limits (dB max.)	Typical Values (dB max.)
1.0-9.9	0.4+0.1*log(f)	0.5 @ 10 MHz
10-49.9	0.5+0.3*log(f/10)	0.7 @ 50 MHz
50-79.9	1+1.4*log(f/80)	1.0 @ 80 MHz
80-100	1.3+3*log(f/100)	1.3 @ 100 MHz
Return Loss		
Frequency f, (MHz)	Limits (dB min.)	Typical Values (dB min.)
1.0-39.9	18	18 @ 40 MHz
40-100	12-20*log(f/80)	10 @ 100 MHz
CMR		
Frequency f, (MHz)	Limits (dB min.)	Typical Values (dB min.)
1.0-100	30	30 @ 100 MHz
NEXT		
Frequency f, (MHz)	Limits (dB min.)	Typical Values (dB min.)
1.0-39.9	35	35 @ 40 MHz
40-100	33-20*log(f/50)	27 @ 100 MHz
Isolation PHY to wire side	2.25 kV DC / 60 s	

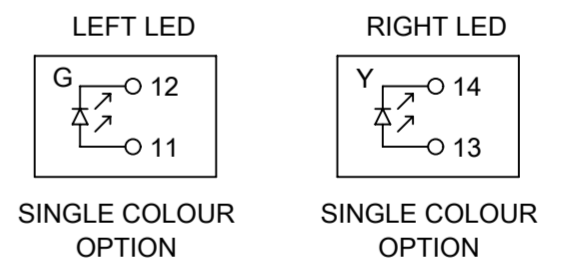

THIS DRAWING CONTAINS INFORMATION THAT IS PROPRIETARY TO MOLEX ELECTRONIC TECHNOLOGIES, LLC AND SHOULD NOT BE USED WITHOUT WRITTEN PERMISSION

DIMENSION UNITS	SCALE	CURRENT REV DESC: UPDATED TITLE		molex			
mm	1:1						
GENERAL TOLERANCES (UNLESS SPECIFIED)				1" MXMAG 4 CORE FE IND REFLOW CAPABLE			
ANGULAR TOL	± 2.0°						
4 PLACES	±	EC NO: 604273		PRODUCT CUSTOMER DRAWING			
3 PLACES	±	DRWN: DSHEA 2018/07/26					
2 PLACES	± 0.1	CHK'D: SMCGREEVY 2018/08/15		DOCUMENT NUMBER			
1 PLACE	± 0.2	APPR: DBYRNES 2019/09/25					
0 PLACES	±	INITIAL REVISION:		937670002			
DRAFT WHERE APPLICABLE MUST REMAIN WITHIN DIMENSIONS		DRWN: DSHEA 2016/07/01					
THIRD ANGLE PROJECTION		APPR: STGRIFFIN 2016/09/23		PSD		000	
DRAWING		SERIES		REVISION		C	
A2-SIZE		93767		MATERIAL NUMBER		SHEET NUMBER	
SEE TABLE ON SHEET 2		GENERAL MARKET		3 OF 3			

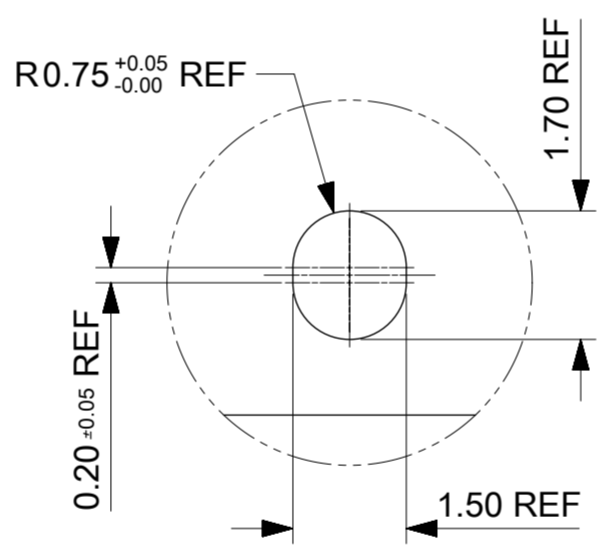
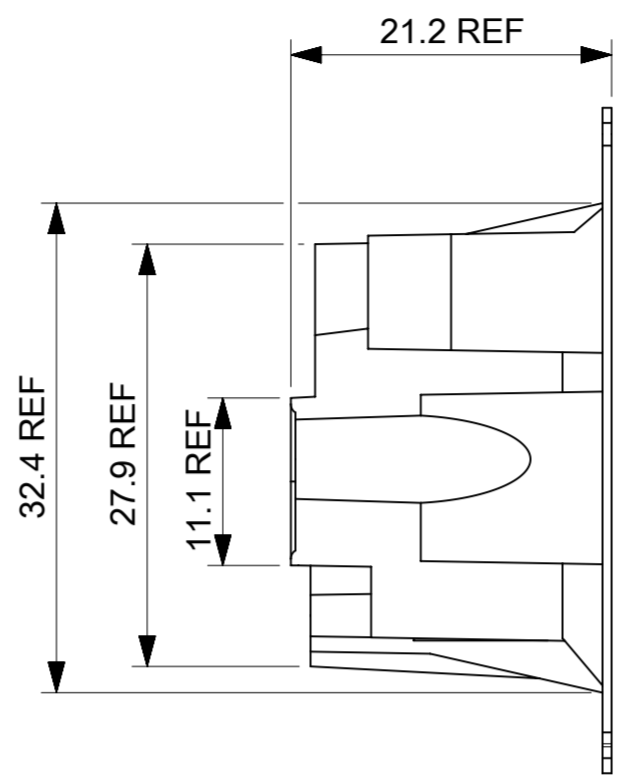
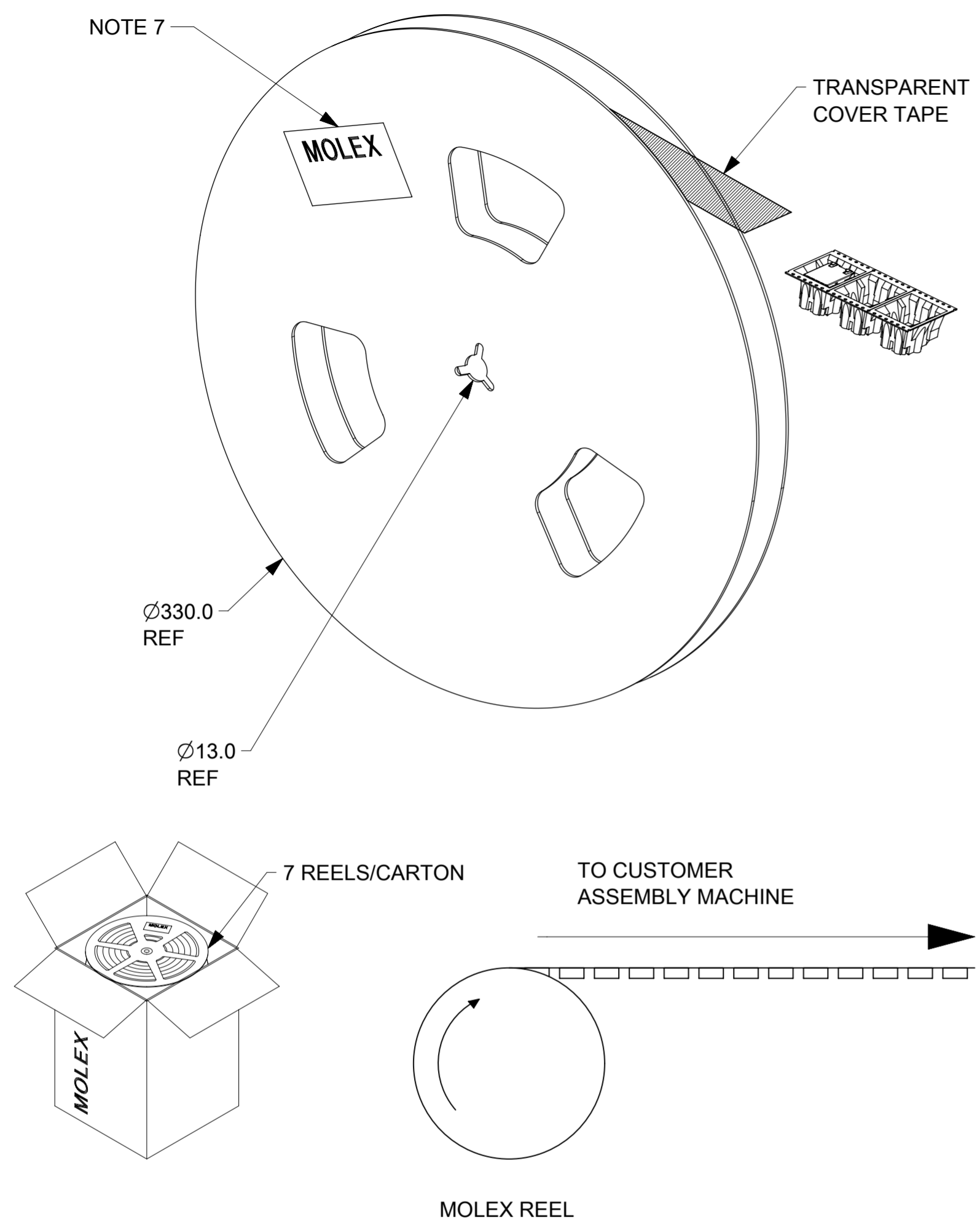

DETAIL A
SCALE 10:1

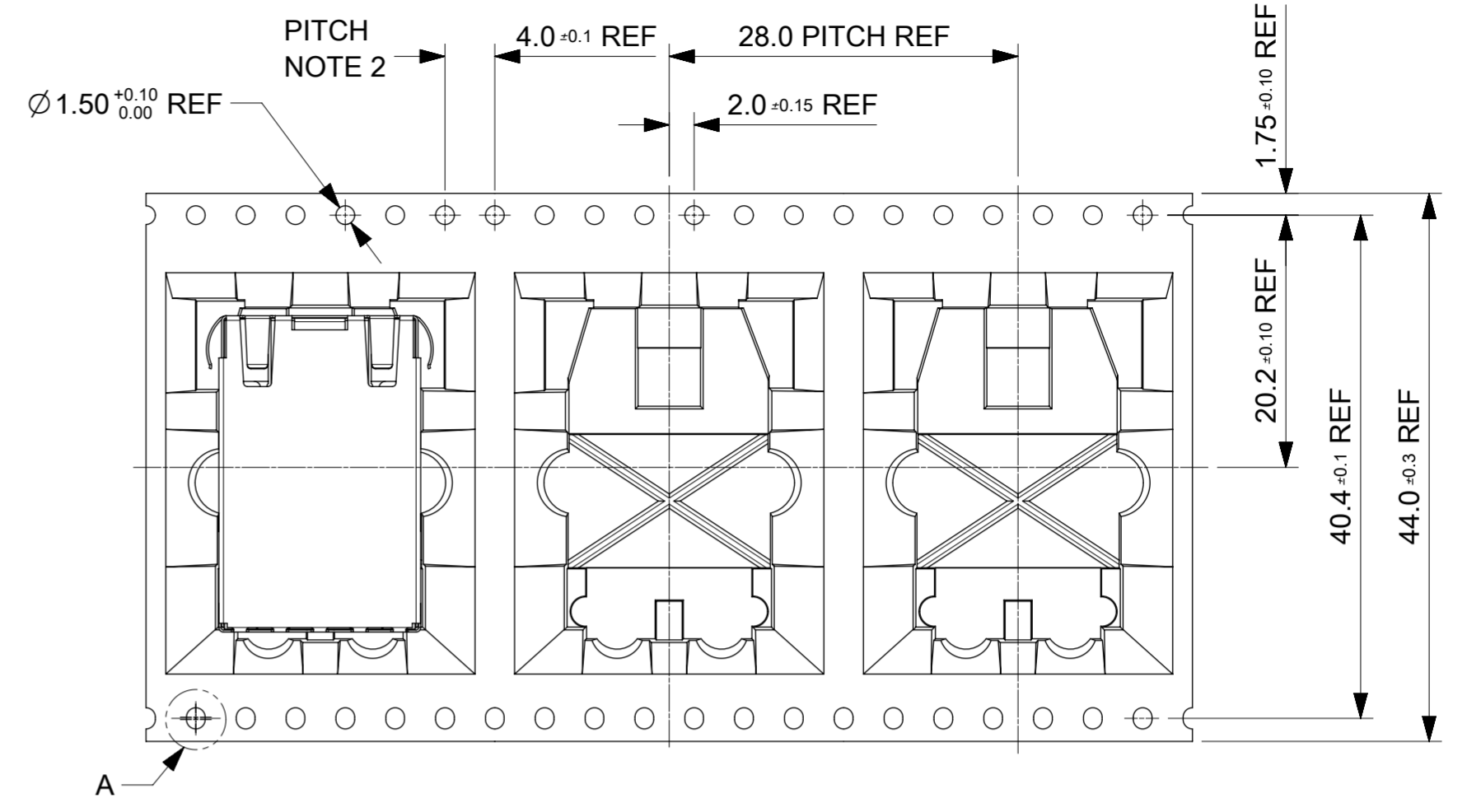

DIRECTION OF UNREELING →

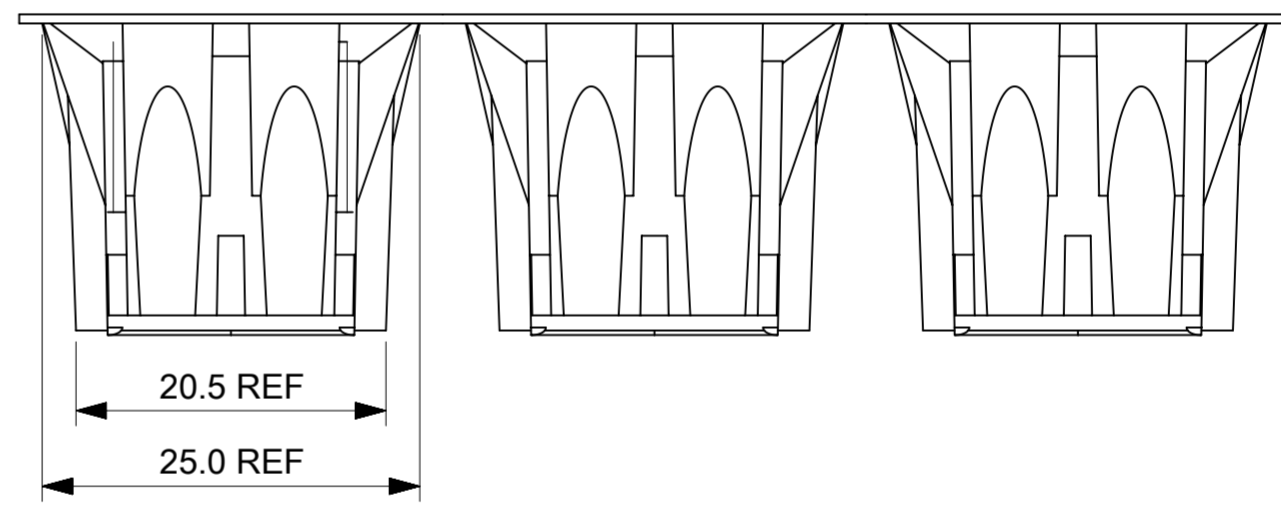

BLISTER TAPE PART NO	PIECES/REEL	PIECES/CARTON	REELS/CARTON
990449058	107	749	7

- NOTES:
- MATERIAL:
CARRIER TAPE: VOLUME CONDUCTIVE POLYSTYRENE, 0.60 mm REF THICK, BLACK.
COVER TAPE: COLD SEAL POLYESTER, 0.06 mm REF THICK TRANSPARENT.
 - PITCH TOLERANCE OVER ANY 10 PITCHES ± 0.2 mm
 - PEEL FORCE OF COVER TAPE IS 0.1 N TO 1.3 N
AT A MAXIMUM SPEED OF 300 mm/min ± 10 mm/min
 - PACKAGING SPECIFICATION: 934620002 PSK.
 - REFERENCE TO IEC 60286-3 EXCEPT WHERE NOTED
 - LABELS SHALL BE PLACED ON THE EACH REEL AND ON THE CARTON
 - THE LABEL ON THE REEL SHALL BE PLACED ON THE OUTSIDE OF THE FLANGE
OPPOSITE THE ROUND SPROCKET HOLES
 - ALL DIMENSIONS ARE REFERENCE ONLY

THIS DRAWING CONTAINS INFORMATION THAT IS PROPRIETARY TO MOLEX ELECTRONIC TECHNOLOGIES, LLC AND SHOULD NOT BE USED WITHOUT WRITTEN PERMISSION

DIMENSION UNITS mm	SCALE 1:2	CURRENT REV DESC: ORIGINAL RELEASE		molex		
GENERAL TOLERANCES (UNLESS SPECIFIED)		EC NO: 624501				
ANGULAR TOL ± 2.0°	4 PLACES ±	DRWN: DSHEA	2019/09/19	PRODUCT CUSTOMER DRAWING		
3 PLACES ±	2 PLACES ± 0.1	CHK'D: DBYRNES	2019/09/26	DOCUMENT NUMBER		
1 PLACE ± 0.2	0 PLACES ±	APPR: DBYRNES	2019/09/26	990449058		
DRAFT WHERE APPLICABLE MUST REMAIN WITHIN DIMENSIONS	THIRD ANGLE PROJECTION	INITIAL REVISION: DRWN: DSHEA APPR: DBYRNES	2019/09/19 2019/09/26	MATERIAL NUMBER	CUSTOMER	DOC TYPE DOC PART REVISION
				99044	990449058	PSD K A
		DRAWING	SERIES	MATERIAL NUMBER	CUSTOMER	SHEET NUMBER
		A2-SIZE	99044	990449058	GENERAL MARKET	1 OF 1