

REVISIONS				
REV	DESCRIPTION	DATE	BY	APP'D
D3	REVISED PER ECR-21-118222	22JUL2022	AVN	VS

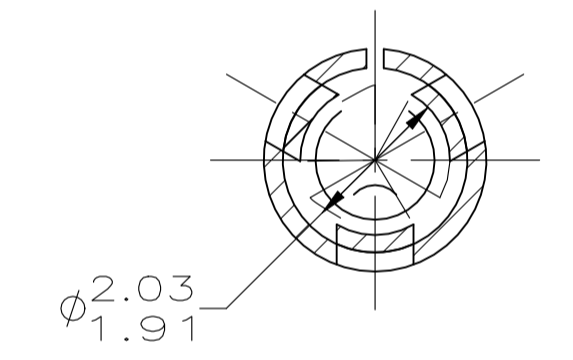

SECTION B-B

SECTION A-A
SCALE 10:1

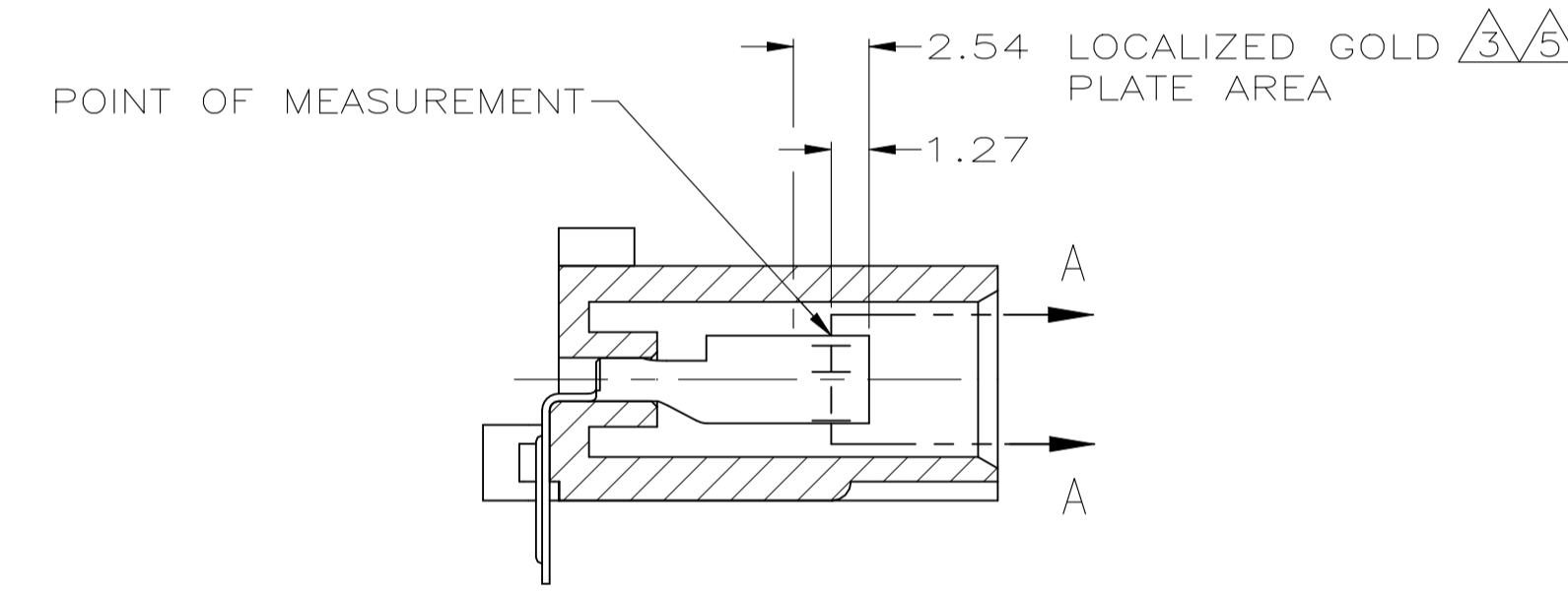
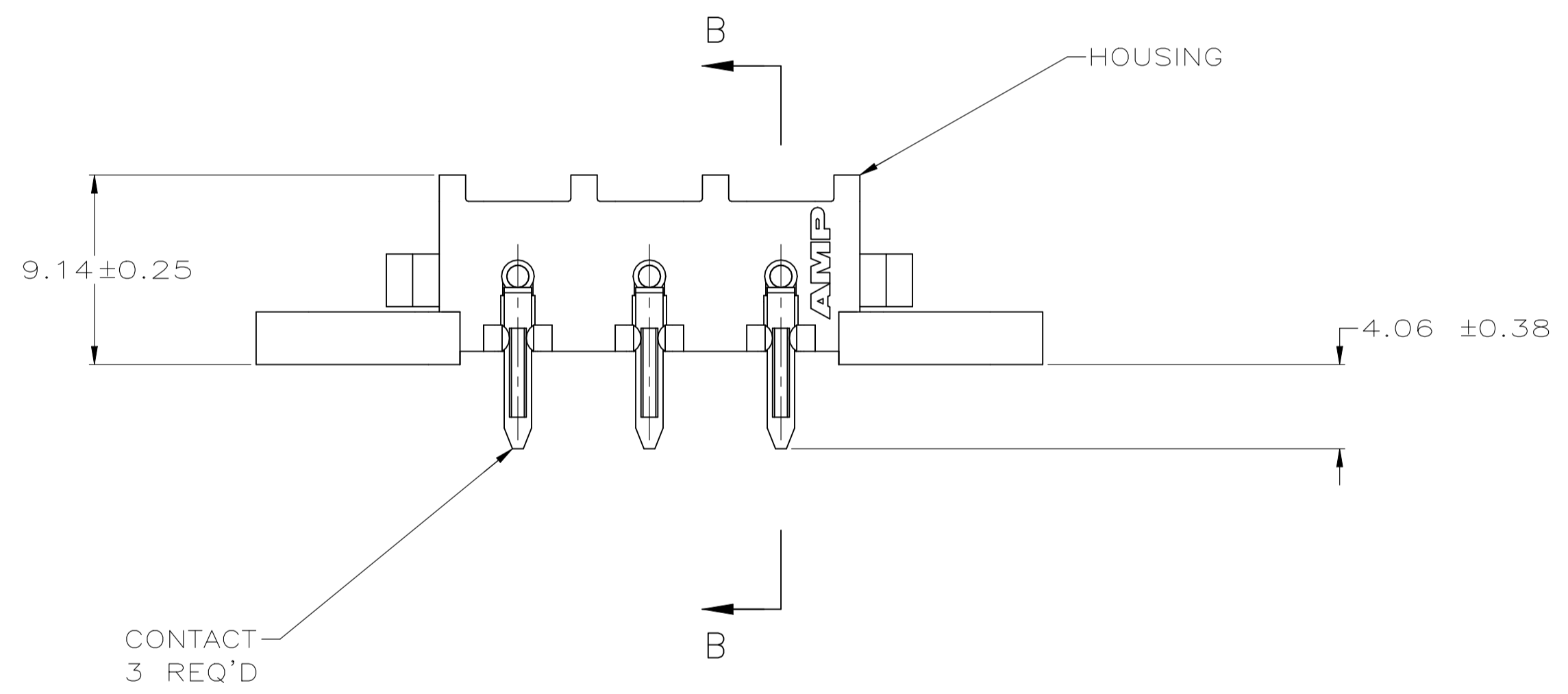
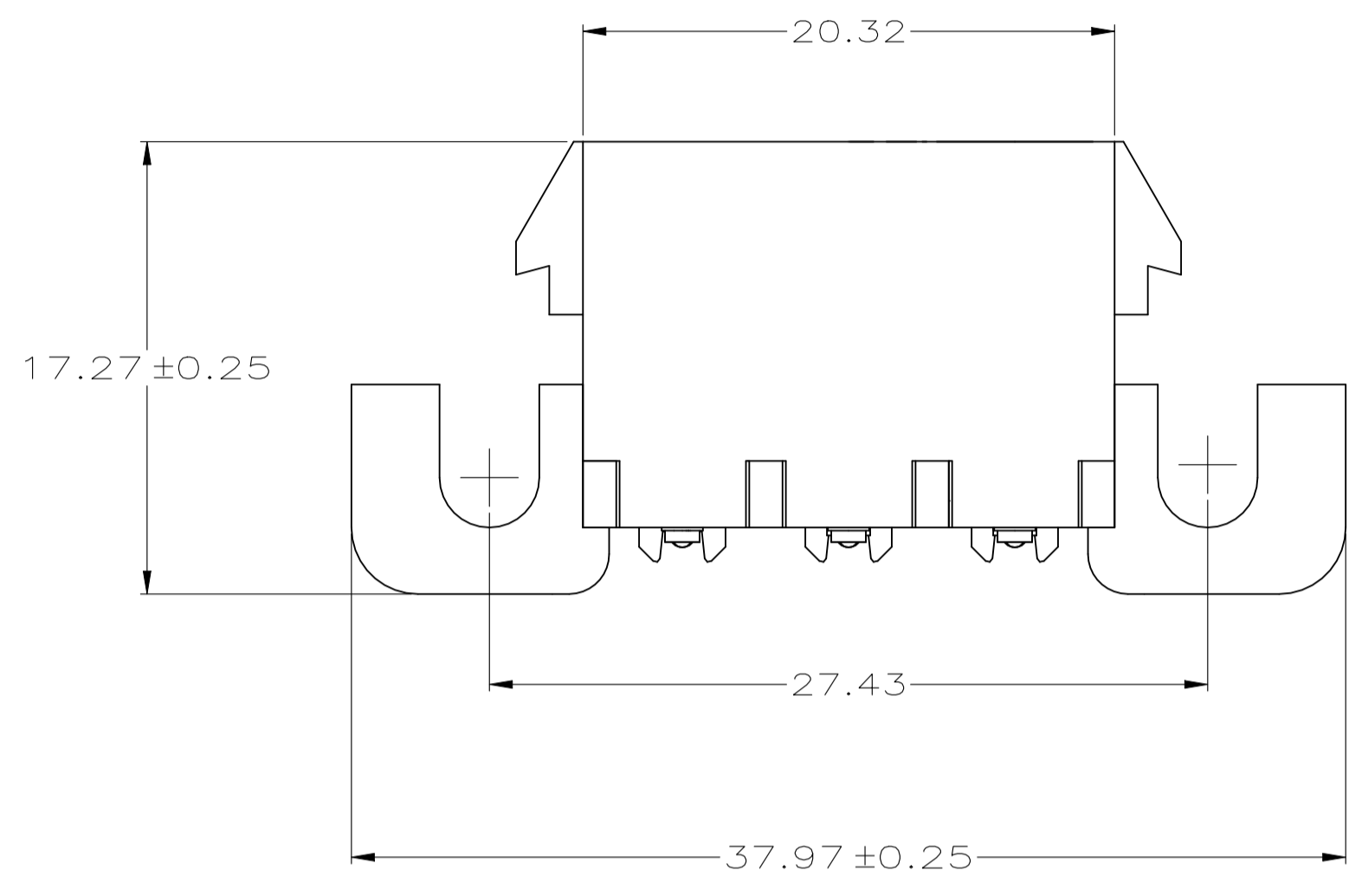
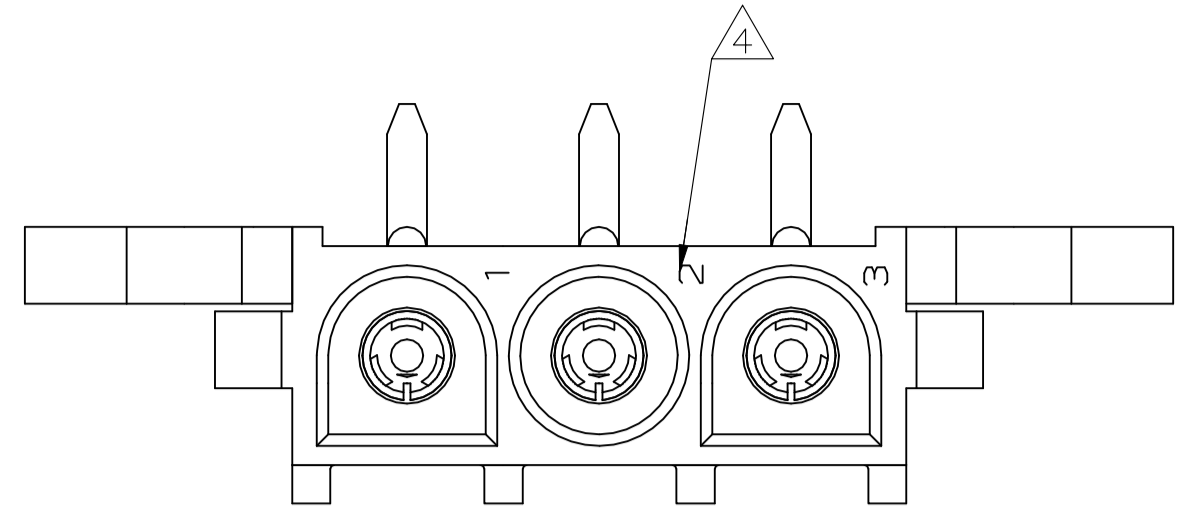
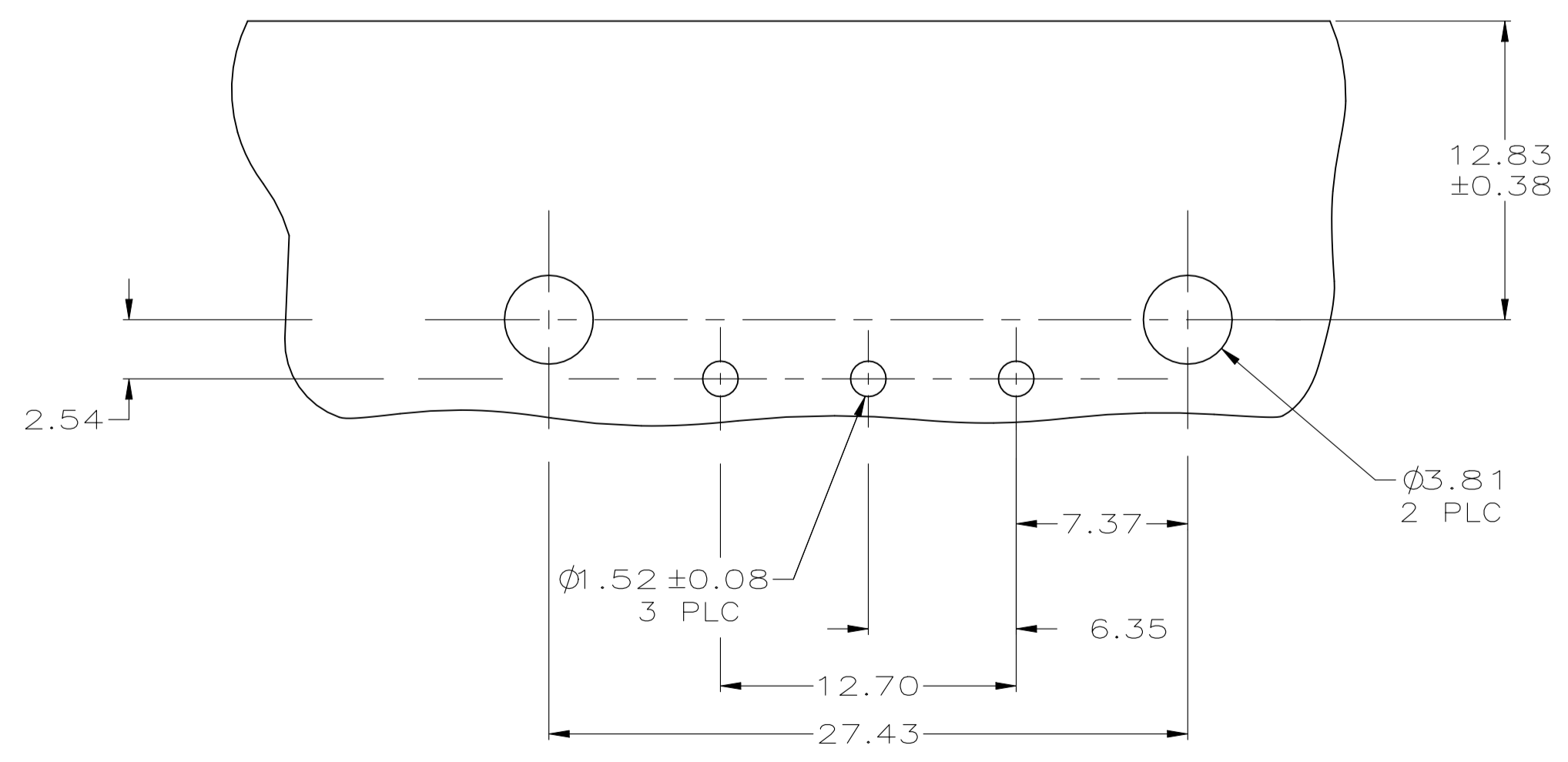

RECOMMENDED MOUNTING HOLE PATTERN FOR 1.57 THICK P.C. BOARD

- 1 PARTS COMPLY WITH AMP SOLDERABILITY SPECIFICATION 109-11-5.
- 3 0.00076 GOLD OVER 0.00127 MIN NICKEL WITH MATTE TIN LEAD ON SOLDER TAIL.
- 4 CIRCUIT IDENTIFICATION CHARACTERS ARE ADJACENT TO THE INDICATED CAVITIES, BUT LOCATION AND ORIENTATION MAY DIFFER FROM PRINT.
- 5 0.00076 GOLD OVER 0.00127 MIN NICKEL WITH MATTE TIN ON SOLDER TAIL.
- 6 SUPERSEDED BY 3-643228-0
- 7 DIMENSIONS SHOWN REPRESENT PRODUCT IN DRY CONDITION. ADDITIONAL 2% GROWTH DUE TO END USE LOCATION MOISTURE ABSORPTION MAY OCCUR AND SHOULD BE ACCOUNTED FOR.

MM	IN	MM	IN
2.54	.100		
2.03	.080	37.97	1.495
1.91	.075	27.43	1.080
1.57	.062	20.32	.800
1.52	.060	17.27	.680
1.27	.050	12.83	.505
0.38	.015	12.70	.500
0.25	.010	9.14	.360
0.13	.005	7.37	.290
0.08	.003	6.35	.250
0.00127	.000050	4.06	.160
0.00076	.000030	3.81	.150
MM	IN	MM	IN

CONVERSION TABLE

PH BRZ, 5	NYLON UL 94V-0	3-643228-0
PH BRZ, 3	NYLON UL 94V-0	643228-2
PH BRZ, TIN	NYLON UL 94V-0	643228-1
CONTACT	HOUSING	PART NUMBER

THIS DRAWING IS A CONTROLLED DOCUMENT.

DIMENSIONS: mm	TOLERANCES UNLESS OTHERWISE SPECIFIED:	DIN K. WHITAKER 21APR2005	TE Connectivity
0 PLC ± -	1 PLC ± -	CHK S. RIDGILL 21APR2005	NAME
2 PLC ± 0.13	3 PLC ± -	APVD S. RIDGILL 21APR2005	PRODUCT SPEC
4 PLC ± -	ANGLES ± -	APPLICATION SPEC	SIZE
MATERIAL SEE TABLE	FINISH SEE TABLE	WEIGHT 0.000000	SCALE 4:1
		CUSTOMER DRAWING	RESTRICTED TO

SOCKET HEADER ASSEMBLY, RIGHT ANGLE MOUNT, 3 POSITION, UNIVERSAL MATE-N-LOK(TM)

SIZE: A1 00779 C=643228

SHEET 1 OF 1 REV D3