

3W

DC-DC CONVERTER

The regulated single output, 3W IZB03 series is an ideal solution for isolating voltage rails in distributed power supply architectures such as analog, digital, data and communication circuits. This product family offers an industry standard "SIP8" format compact design with high efficiency, 1.5kV isolation, optional 3kV, remote On/Off, enhanced ripple filter function and short circuit protection.



Features

- Regulated single output
- 2:1 input range
- Single outputs 3.3 to 24VDC
- SIP8 package
- 1.5 kVDC functional isolation, optional 3kVDC
- Continuous short circuit protection
- Class B conducted & radiated emissions
- Remote On/Off
- -40°C to +85°C operating temperature
- 3 year warranty

Applications



Industrial Electronics



Instrumentation



Robotics



Technology

Dimensions

0.86" x 0.37" x 0.47" (22.0 x 9.5 x 12.0mm)

General

Characteristic	Minimum	Typical	Maximum	Units	Notes & Conditions
Efficiency		80		%	See models & ratings table
Isolation: Input to Output	1500			VDC	60s test, optional 3.0kV add suffix -H
Isolation Resistance	10 ⁹			Ω	
Isolation Capacitance		120		pF	
Switching Frequency		250		kHz	100% load, nominal input voltage
Power Density			20	W/in ³	
Mean Time Between Failure	1.0			Mhrs	MIL-HDBK-217F, +25°C GB
Weight		0.01 (4.5)		lb (g)	
Case Material	Black plastic, flame retardant UL94V-0				
Pin Material	Phosphor bronze, solder coated				
Solder Profile			300	°C	1.5mm from case 10s max.
Water Wash	Use deionized water, dry thoroughly, do not soak				

Models & Ratings

Model Number	Input Voltage	Output Voltage	Output Current	Input Current (no load)	Input Current (full load)	Maximum Capacitive Load	Efficiency at Vin Nominal with Full Load ⁽¹⁾
IZB0305S3V3	5V (4.5-9.0V)	3.3V	758mA	85mA	758mA	1800µF	68%
IZB0305S05		5V	500mA		2200µF	73%	
IZB0305S09		9V	278mA		1000µF	74%	
IZB0305S12		12V	208mA		680µF	77%	
IZB0305S15		15V	167mA		470µF	74%	
IZB0305S24		24V	104mA		330µF	76%	
IZB0312S3V3	12V (9.0-18.0V)	3.3V	758mA	40mA	286mA	2700µF	75%
IZB0312S05		5V	600mA		2200µF	76%	
IZB0312S06		6V	500mA		1800µF	79%	
IZB0312S09		9V	333mA		1000µF	79%	
IZB0312S12		12V	250mA		680µF	82%	
IZB0312S15		15V	200mA		470µF	83%	
IZB0312S24	24V	125mA	330µF	81%			
IZB0324S3V3	24V (18.0-36.0V)	3.3V	758mA	40mA	145mA	2700µF	74%
IZB0324S05		5V	600mA		2200µF	81%	
IZB0324S09		9V	333mA		1000µF	83%	
IZB0324S12		12V	250mA		680µF	83%	
IZB0324S15		15V	200mA		470µF	83%	
IZB0324S24		24V	125mA		330µF	83%	
IZB0348S3V3	48V (36.0-75.0V)	3.3V	758mA	15mA	72mA	2700µF	75%
IZB0348S05		5V	600mA		2200µF	76%	
IZB0348S12		12V	250mA		680µF	80%	
IZB0348S15		15V	200mA		470µF	84%	
IZB0348S24		24V	125mA		330µF	82%	

Notes:

1. Measured at nominal input voltage and full load.
2. For 3kVDC isolation add suffix -H

3. Pack size 22pcs per tube

Input

Characteristic	Minimum	Typical	Maximum	Units	Notes & Conditions
Input Voltage Range	4.5		9.0	VDC	5V nominal
	9.0		18.0		12V nominal
	18.0		36.0		24V nominal
	36.0		75.0		48V nominal
Input Filter	Capacitor				
Input Reflected Ripple		20/55		mA pk-pk	IZB0305 or 12 / IZB0324 or 48. Measured through 4.7µH inductor and 220µF capacitor.
Input Surge	-0.7		12	VDC	5V models, 1s
	-0.7		25		12V models, 1s
	-0.7		50		24V models, 1s
	-0.7		100		48V models, 1s
Fuse	Slow blow, select based on model used				

Output

Characteristic	Minimum	Typical	Maximum	Units	Notes & Conditions
Output Voltage	3.3		24	VDC	See models & ratings table
Initial Set Accuracy		1		%	
Minimum Load	0			%	Operation at no load will not cause damage
No-load Output Voltage Accuracy		±5	±8	%	IZB0312S3V3 and IZB0348S3V3
		±1.5	±5		Other models
Line Regulation			0.5	%	Per 1% change of input voltage
Load Regulation			1.0	%	From 5% to full load.
Transient Response		2.5		%	25% step load change, recovery within 3ms
Ripple & Noise*			75	mV pk-pk	All other models
			100		IZB0312S12/15, 48S24
			150		IZB0312S24, 24S15, 24S24, 48S05, 48S3V3
Short Circuit Protection	Continuous, with autorecovery				
Maximum Capacitive Load	See models & ratings table				
Temperature Coefficient		±0.02		%/°C	100% load
Remote On/Off	Output is on if remote On/Off pin 3 is open circuit. Output is off if a control current of 5-10mA flows into pin 3. See application note.				

Notes:

*Measured using parallel cable, 20MHz bandwidth and 10µF ceramic capacitor. See application note for enhanced ripple filter option using ripple control pin 8.

Environmental

Characteristic	Minimum	Typical	Maximum	Units	Notes & Conditions
Operating Temperature	-40		+85	°C	See application note derating curve
Storage Temperature	-55		+125	°C	
Case Temperature			105	°C	
Humidity			95	%RH	Non-condensing
Cooling	Natural convection				

Safety Approvals

Safety Agency	Standard	Notes & Conditions
UL	UL/cUL62368-1	ITE
CE	Meets all applicable directives	
UKCA	Meets all applicable legislation	

EMC: Emissions

Phenomenon	Standard	Test Level	Notes & Conditions
Conducted	EN55032	Class B	See application notes
Radiated	EN55032	Class B	See application notes

EMC: Immunity

Phenomenon	Standard	Test Level	Criteria	Notes & Conditions
ESD Immunity	EN61000-4-2	3	B	Air ±8kV, Contact ±4kV
Radiated Immunity	EN61000-4-3	3	A	10V/m
EFT/Burst	EN61000-4-4	3	B	External input capacitor required 330µF/100V, ±2kV
Surge	EN61000-4-5	3	B	External input capacitor required 330µF/100V, line to line, ±2kV
Conducted Immunity	EN61000-4-6	2	A	3Vrms

Application Notes

EMC (Class B) Compliance Circuit

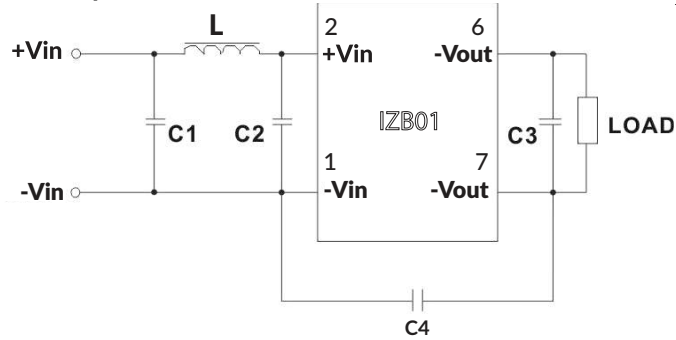

Input Voltage	C1	C2	C3	C4	L
5	4.7 μ F/50V	4.7 μ F/50V	100 μ F/50V	1nF 2kV	12 μ H
12					
24					
48	4.7 μ F/100V	4.7 μ F/100V			

Notes: To further reduce ripple increase C1, C2 and C3 and use low ESR type capacitors.

Enhanced Ripple Filtering

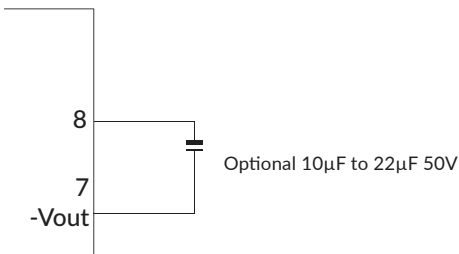

The internal filter can be enhanced by adding 10-22 μ F/50V capacitor between ripple control pin 8 and -Vout. For example, adding a 10 μ F capacitor can reduce ripple by 10% with full load.

Remote On/Off

Fig 1.

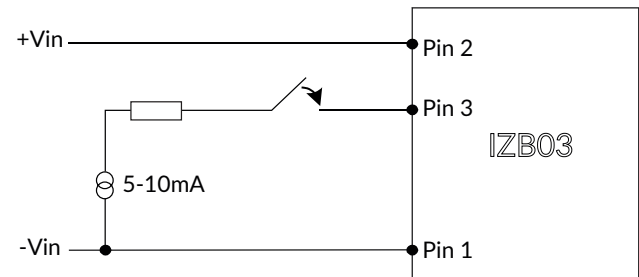

Module "On" if pin 3 is open circuit

Module "Off" if connected to current source of 5-10mA maximum

Note: Open circuit 1V present at pin 3 with 300 Ω internal resistor.

Temperature Derating Curve

Fig 2.

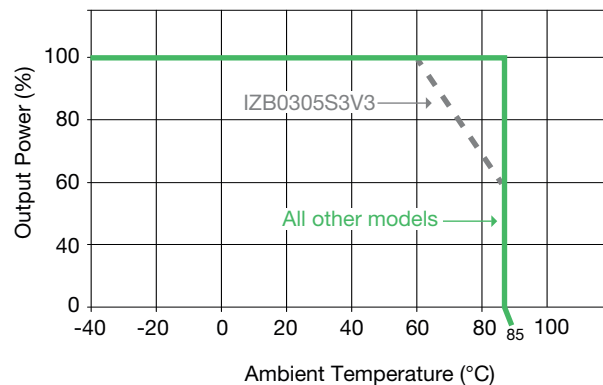

Mechanical Details

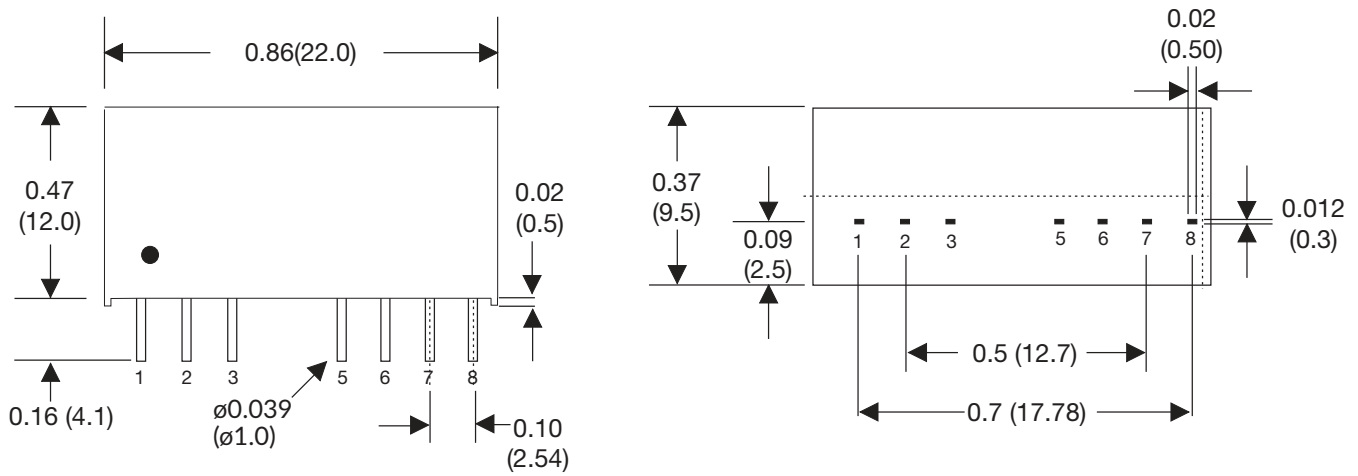

Pin Connections			
Pin	Function	Pin	Function
1	-Vin	5	No connection
2	+Vin	6	+Vout
3	Remote On/Off	7	-Vout
4	No pin	8	Ripple control

Notes:

1. All dimensions are in inches (mm)
2. Weight: 0.01 (4.5g)

3. Pin tolerance: $\pm 0.004''$ ($\pm 0.1\text{mm}$)
4. Case tolerance: $\pm 0.01''$ ($\pm 0.25\text{mm}$)