

THIS DRAWING IS UNPUBLISHED. RELEASED FOR PUBLICATION 20  
 © COPYRIGHT 20 BY - ALL RIGHTS RESERVED.

LOC		DIST		REVISIONS			
P	LTR	DESCRIPTION	DATE	DWN	APVD		
	A	RELEASE	31DEC2015	JY	SH		
	A1	REVISED PER ECN-22-163746	11JUL2022	IT	SZ		

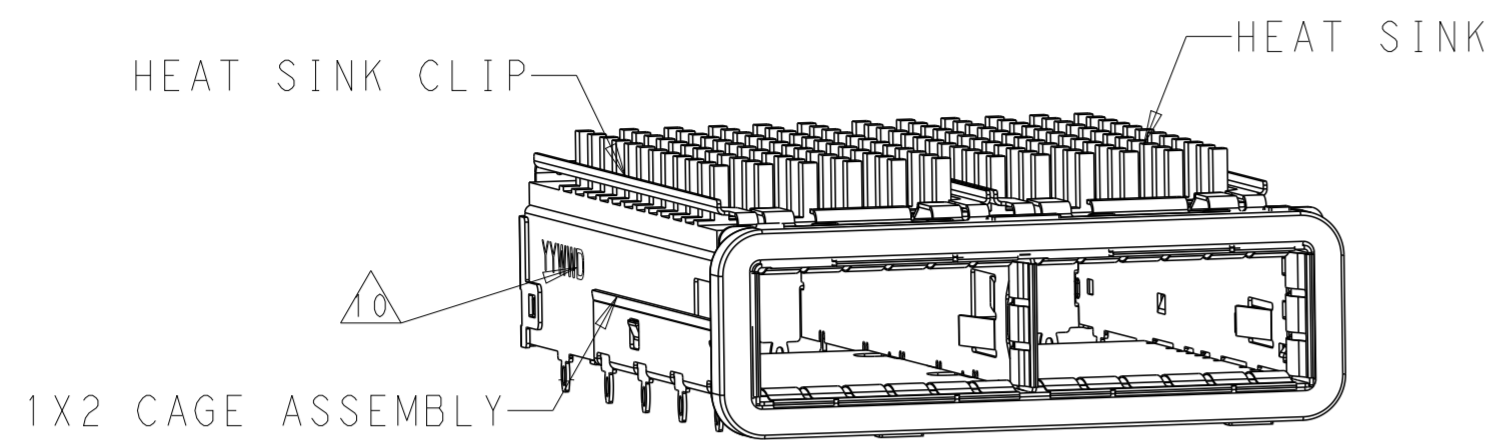

2170812-2 AS SHOWN  
SCALE 2:1

- COMPONENTS  
 CAGE ASSEMBLY: NICKEL-SILVER ALLOY  
 HEAT SINK: ALUMINUM/BLACK ANODIZE  
 HEAT SINK CLIP: STAINLESS STEEL  
 EMI SPRING: COPPER ALLOY/NICKEL PLATE
- REFERENCE APPLICATION SPECIFICATION 114-32023 FOR RECOMMENDED DRILL HOLE DIAMETER AND PLATING THICKNESS
- DATUM AND BASIC DIMENSION ESTABLISHED BY CUSTOMER
- DIMENSION APPLIES WITH MODULE INSERTED IN CAGE
- HEAT SINKS, HEAT SINK CLIPS AND LIGHT PIPES ARE SHIPPED ASSEMBLED ON CAGE
- MINIMUM PC BOARD THICKNESS:  
 SINGLE SIDED: 1.57 MIN  
 DOUBLE SIDED: 3.00 MIN
- DATUM **-A-** IS TOP SURFACE OF THE HOST BOARD.
- THESE HOLES ARE OPTIONAL WHEN THE REAR PINS ARE REMOVED.
- MATES WITH QSFP28 MSA COMPATIBLE TRANSCEIVER.
- DATE CODE (YYWWD) MARKED APPROXIMATELY AS SHOWN.

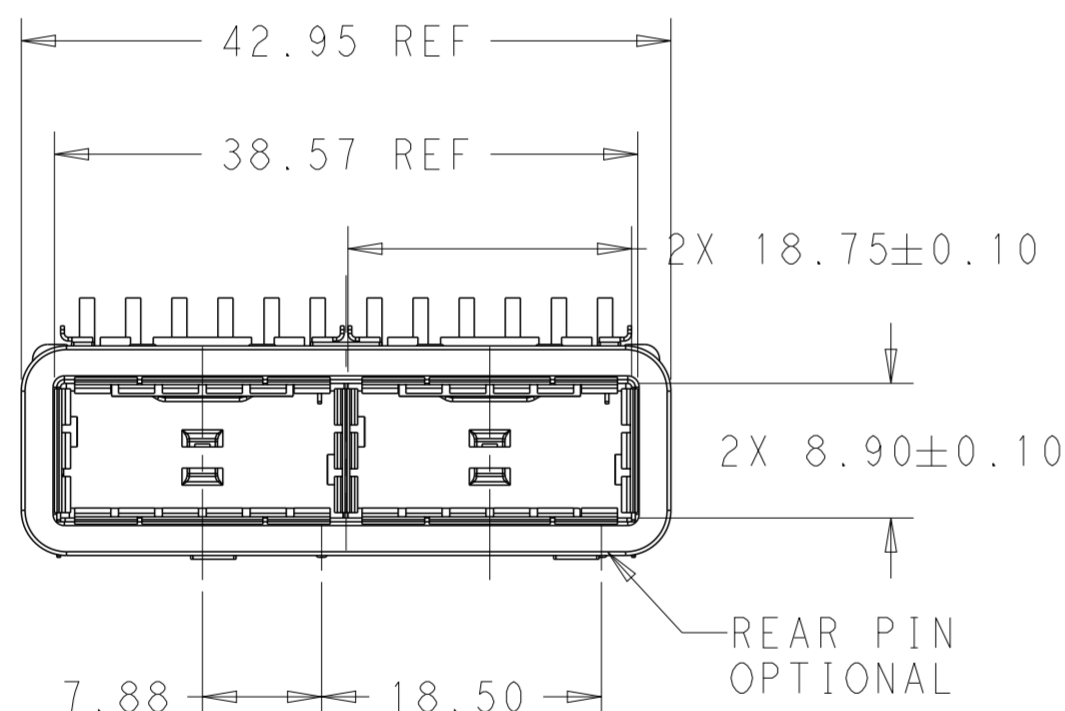

SCALE 2:1

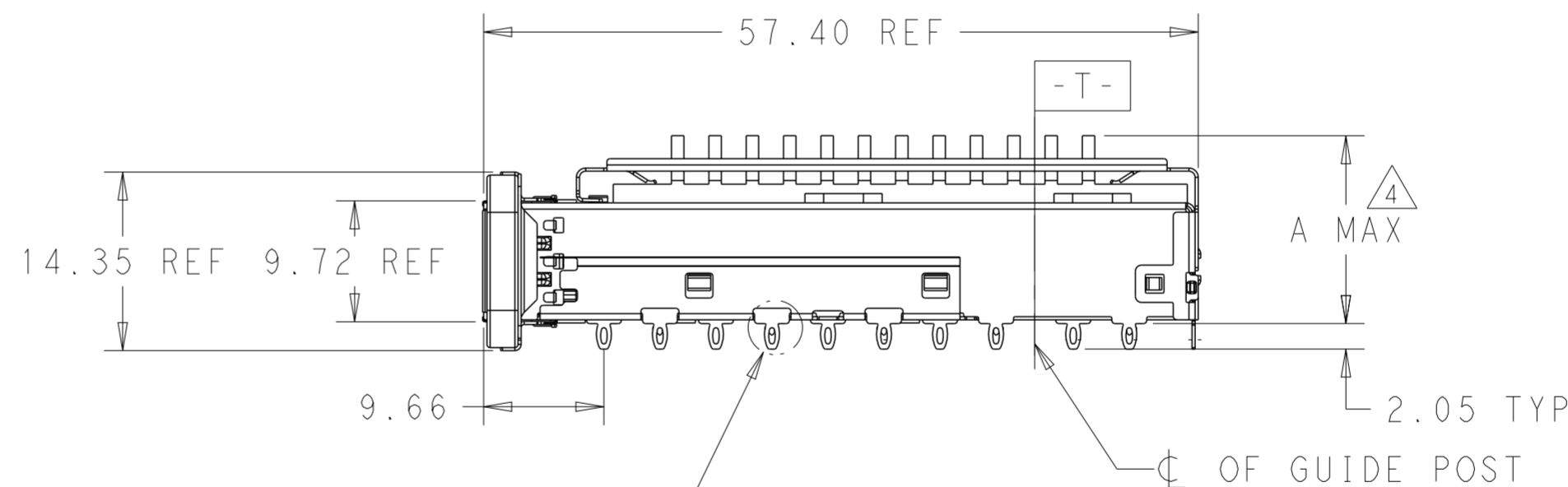

SEE DETAIL D

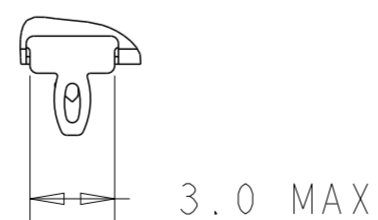

DETAIL D  
SCALE 4:1

23.0	WITHOUT	NETWORKING	2170812-6
16.0	WITHOUT	SAN	2170812-5
13.7	WITHOUT	PCI	2170812-4
23.0	WITH	NETWORKING	2170812-3
16.0	WITH	SAN	2170812-2
13.7	WITH	PCI	2170812-1
DIM A	REAR PINS OPTIONAL	APPLICATION	PART NUMBER

THIS DRAWING IS A CONTROLLED DOCUMENT.		DWN BING LIU 15SEP2014	TE Connectivity	
DIMENSIONS: mm		CHK JASON YANG 15SEP2014		
TOLERANCES UNLESS OTHERWISE SPECIFIED:		APVD SEAN HAN 26OCT2015	NAME RECEPTACLE CAGE ASSEMBLY WITH HEAT SINKS THRU BEZEL, 1X2, QSFP28	
0 PLC ± 1 PLC ±0.25 2 PLC ±0.2 3 PLC ± 4 PLC ±		PRODUCT SPEC 108-19428	SIZE A2	
MATERIAL SEE NOTES		APPLICATION SPEC 114-32023	DRAWING NO C-2170812	
FINISH SEE NOTES		WEIGHT -	RESTRICTED TO -	
		CUSTOMER DRAWING	SCALE 1:1	SHEET 1 OF 5 REV A1

THIS DRAWING IS UNPUBLISHED. RELEASED FOR PUBLICATION 20  
 © COPYRIGHT 20 BY - ALL RIGHTS RESERVED.

LOC		DIST		REVISIONS			
P	LTR	DESCRIPTION		DATE	DWN	APVD	
rev_sym_1	16E6-8HBEI11			rev.date	rev.dwn	rev.appr	1
rev_sym_2	rev_desc_2			rev.date	rev.dwn	rev.appr	2
rev_sym_3	rev_desc_3			rev.date	rev.dwn	rev.appr	3
rev_sym_4	rev_desc_4			rev.date	rev.dwn	rev.appr	4

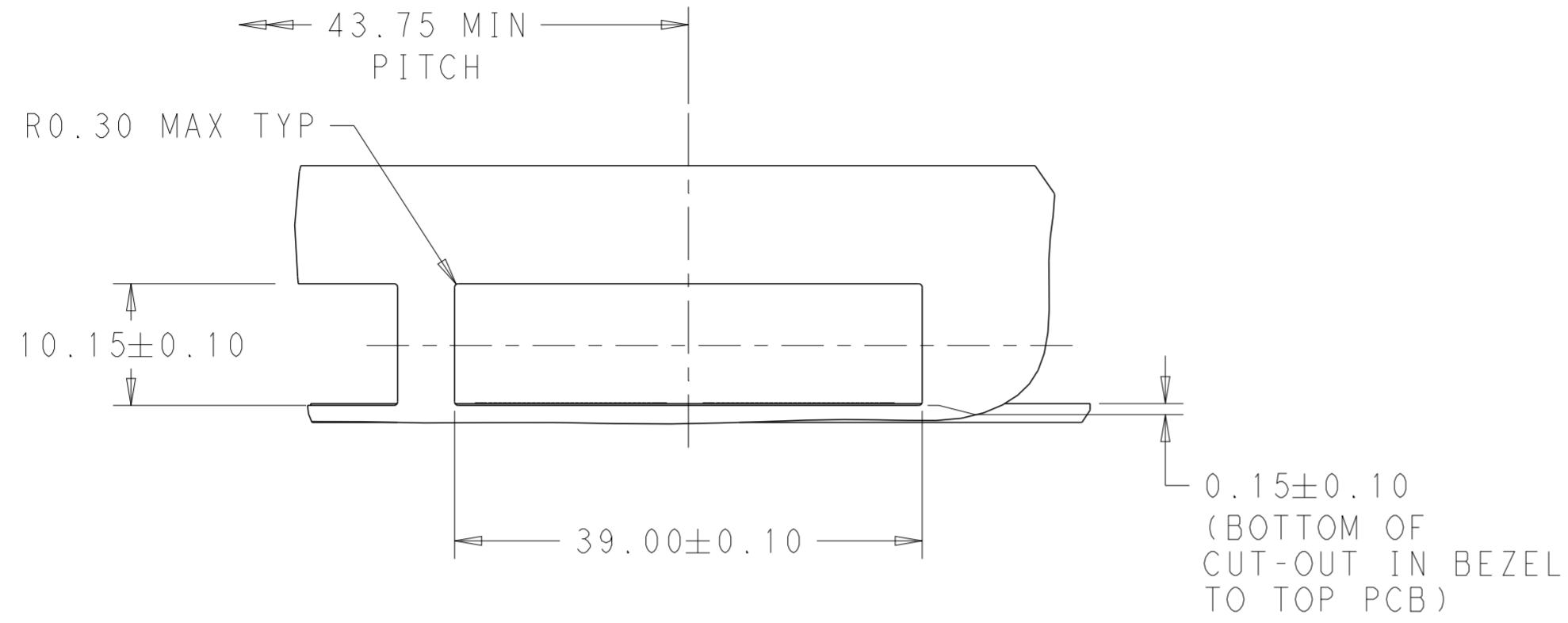

CAGE ASSEMBLY IS OMITTED

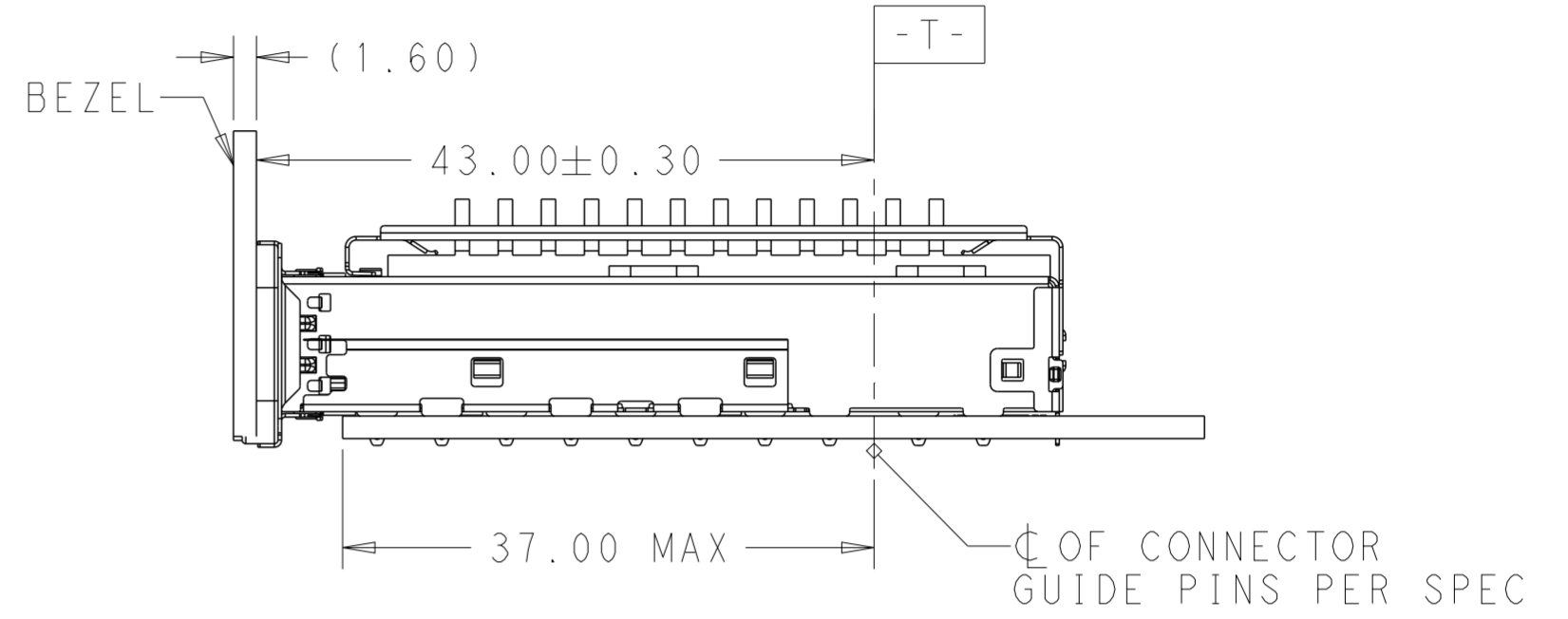

SINGLE SIDE MOUNTING  
SCALE 2:1

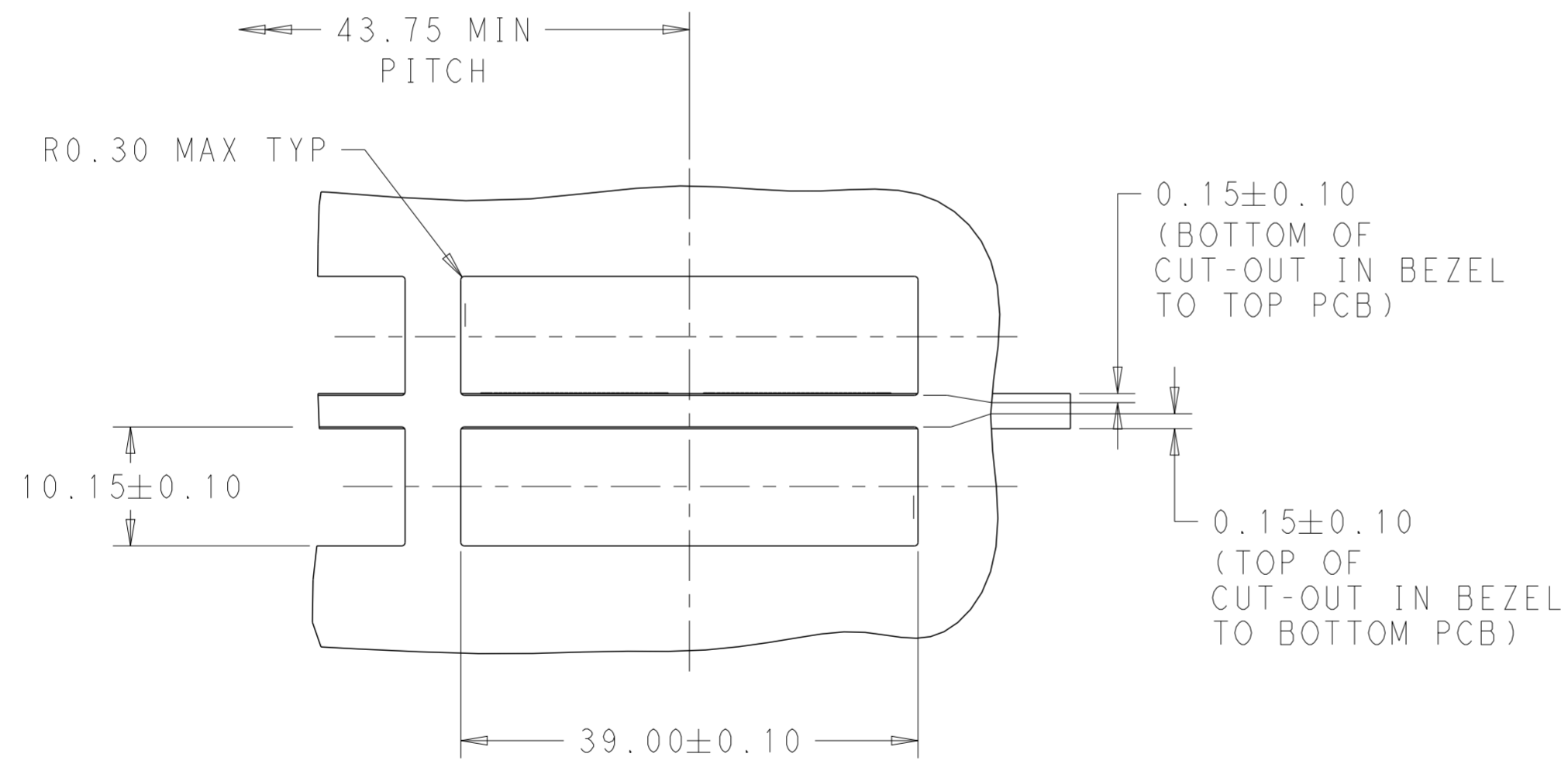

CAGE ASSEMBLY IS OMITTED

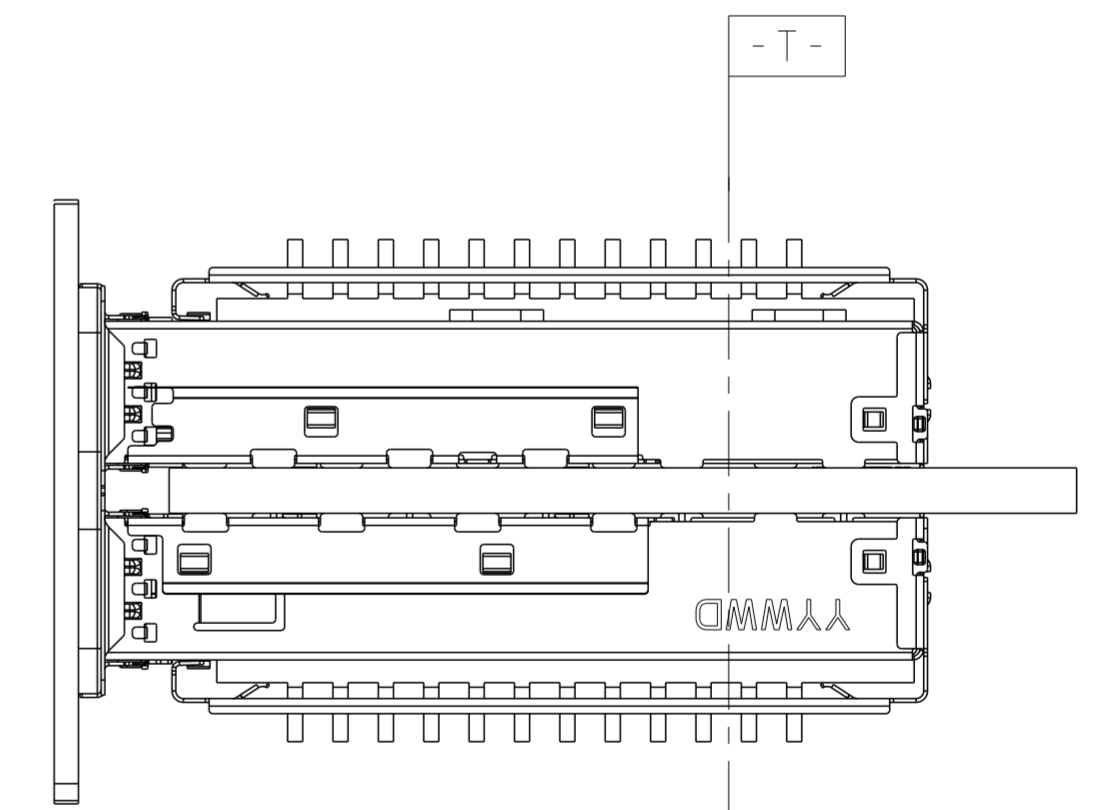

BELLY TO BELLY MOUNTING  
SCALE 2:1

THIS DRAWING IS A CONTROLLED DOCUMENT.		DWN BING LIU 15SEP2014	TE Connectivity	
DIMENSIONS: mm		CHK JASON YANG 15SEP2014		
TOLERANCES UNLESS OTHERWISE SPECIFIED:		APVD SEAN HAN 26OCT2015	NAME RECEPTACLE CAGE ASSEMBLY WITH HEAT SINKS THRU BEZEL, 1X2, QSFP28	
		PRODUCT SPEC 108-19428	SIZE A200779	
MATERIAL SEE NOTES material_2		APPLICATION SPEC 114-32023	DRAWING NO C-2170812	
FINISH SEE NOTES finish_spec_2		WEIGHT -	RESTRICTED TO -	
Customer Drawing		SCALE 1:1	SHEET 2 OF 5	
				REV A1

THIS DRAWING IS UNPUBLISHED. RELEASED FOR PUBLICATION 20  
 © COPYRIGHT 20 BY - ALL RIGHTS RESERVED.

LOC		DIST		REVISIONS			
P	LTR	DESCRIPTION	DATE	DWN	APVD		
rev_sym_1	16E8HBEI11			rev.dater	lev.dwn	lapp	1
rev_sym_2	rev_desc_2			rev.dater	lev.dwn	lapp	2
rev_sym_3	rev_desc_3			rev.dater	lev.dwn	lapp	3
rev_sym_4	rev_desc_4			rev.dater	lev.dwn	lapp	4

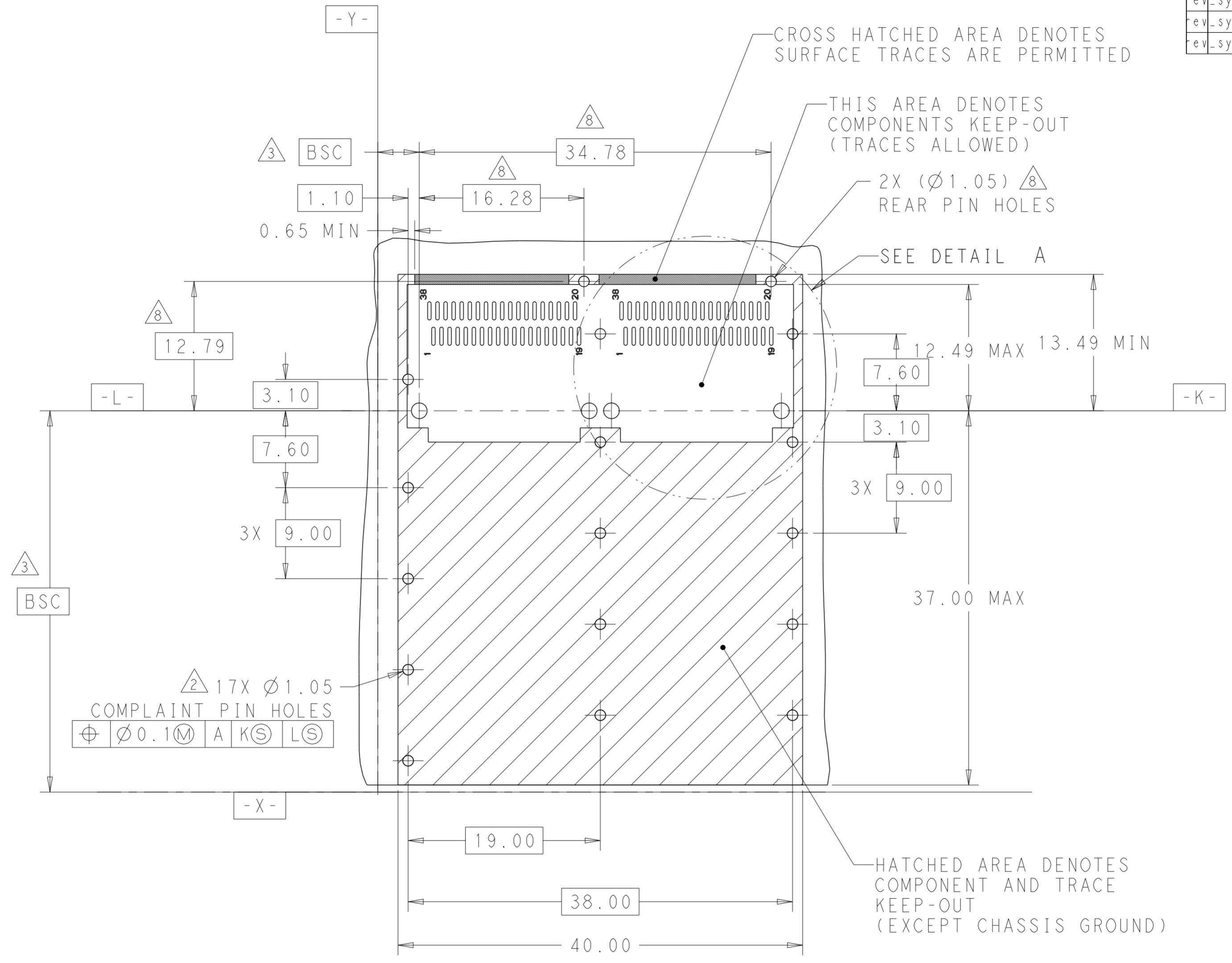

RECOMMENDED PCB LAYOUT  
 SINGLE TYPE  
 PCB TOLERANCE: ±0.05  
 SCALE 3:1

THIS DRAWING IS A CONTROLLED DOCUMENT.		DWN BING LIU 15SEP2014	TE Connectivity	
DIMENSIONS: mm		CHK JASON YANG 15SEP2014		
TOLERANCES UNLESS OTHERWISE SPECIFIED:		APVD SEAN HAN 26OCT2015	NAME RECEPTACLE CAGE ASSEMBLY WITH HEAT SINKS THRU BEZEL, 1X2, QSFP28	
		PRODUCT SPEC 108-19428	SIZE A2	
MATERIAL SEE NOTES material_2		APPLICATION SPEC 114-32023	CAGE CODE 00779	DRAWING NO C-2170812
FINISH SEE NOTES finish_spec_2		WEIGHT -	RESTRICTED TO -	SCALE 1:1 SHEET 3 OF 5 REV A1
		Customer Drawing		

THIS DRAWING IS UNPUBLISHED. RELEASED FOR PUBLICATION 20  
 © COPYRIGHT 20 BY - ALL RIGHTS RESERVED.

LOC		DIST		REVISIONS			
P	LTR	DESCRIPTION	DATE	DWN	APVD		
rev_sym_1	16E6-8HBEI11		rev.date	rev.dwn	rev.appr	.1	
rev_sym_2	rev_desc_2		rev.date	rev.dwn	rev.appr	.2	
rev_sym_3	rev_desc_3		rev.date	rev.dwn	rev.appr	.3	
rev_sym_4	rev_desc_4		rev.date	rev.dwn	rev.appr	.4	

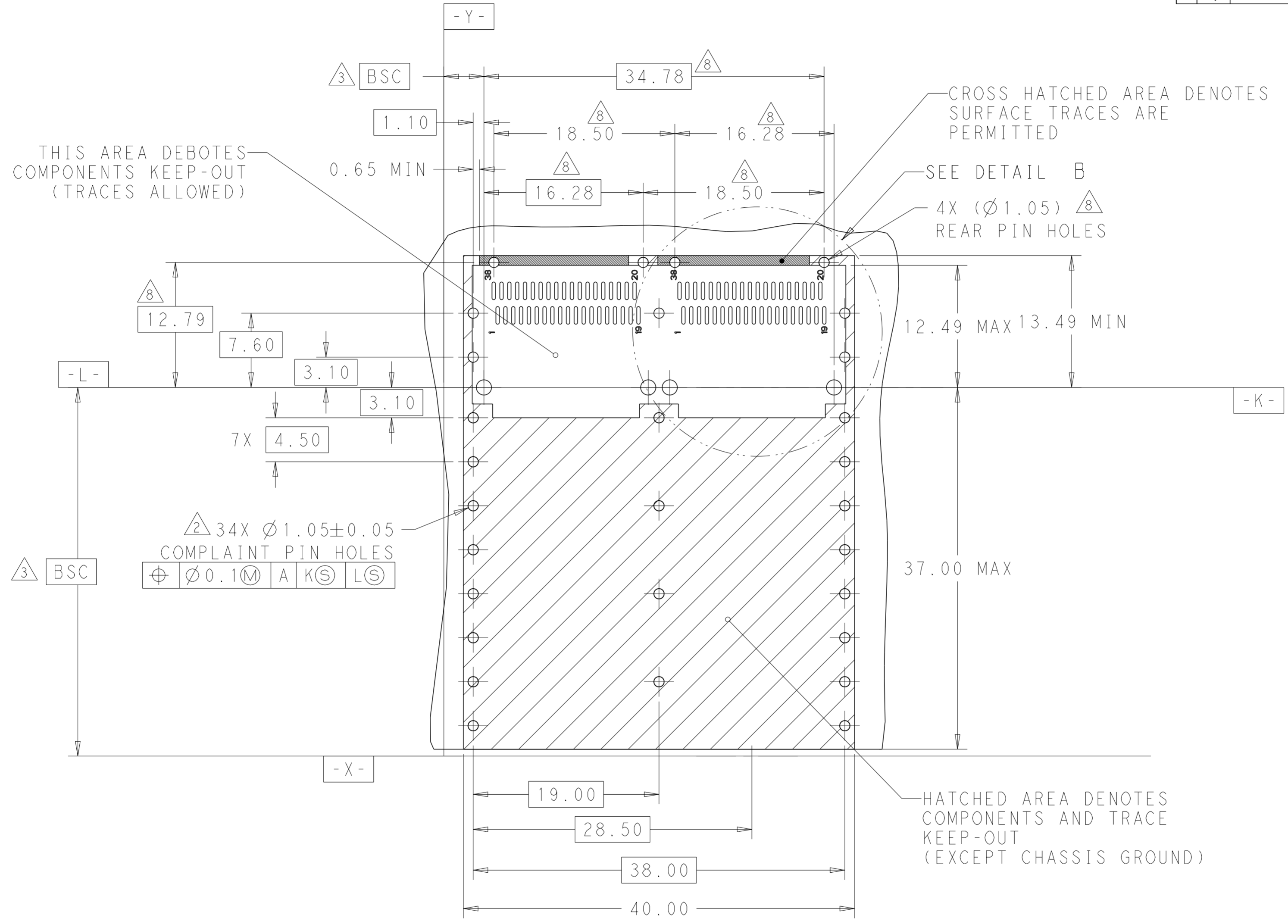

RECOMMENDED PCB LAYOUT  
 BELLY TO BELLY TYPE  
 PCB TOLERANCE: ±0.05  
 SCALE 3:1

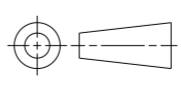
THIS DRAWING IS A CONTROLLED DOCUMENT.		DWN BING LIU 15SEP2014	 TE Connectivity	
DIMENSIONS: mm		CHK JASON YANG 15SEP2014		
TOLERANCES UNLESS OTHERWISE SPECIFIED:		APVD SEAN HAN 26OCT2015	NAME RECEPTACLE CAGE ASSEMBLY WITH HEAT SINKS THRU BEZEL, 1X2, QSFP28	
		PRODUCT SPEC 108-19428	SIZE A2	
MATERIAL SEE NOTES material_2		APPLICATION SPEC 114-32023	CAGE CODE 00779	DRAWING NO C-2170812
FINISH SEE NOTES finish_spec_2		WEIGHT -	RESTRICTED TO -	SCALE 1:1
		Customer Drawing	SHEET 4 OF 5	REV A1

THIS DRAWING IS UNPUBLISHED. RELEASED FOR PUBLICATION 20  
 © COPYRIGHT 20 BY - ALL RIGHTS RESERVED.

LOC	DIST	REVISIONS			
P	LTR	DESCRIPTION	DATE	DWN	APVD
rev_sym_1	16E6-8HBEI11		rev.date	rev.dwn	rev.appr
rev_sym_2	rev_desc_2		rev.date	rev.dwn	rev.appr
rev_sym_3	rev_desc_3		rev.date	rev.dwn	rev.appr
rev_sym_4	rev_desc_4		rev.date	rev.dwn	rev.appr

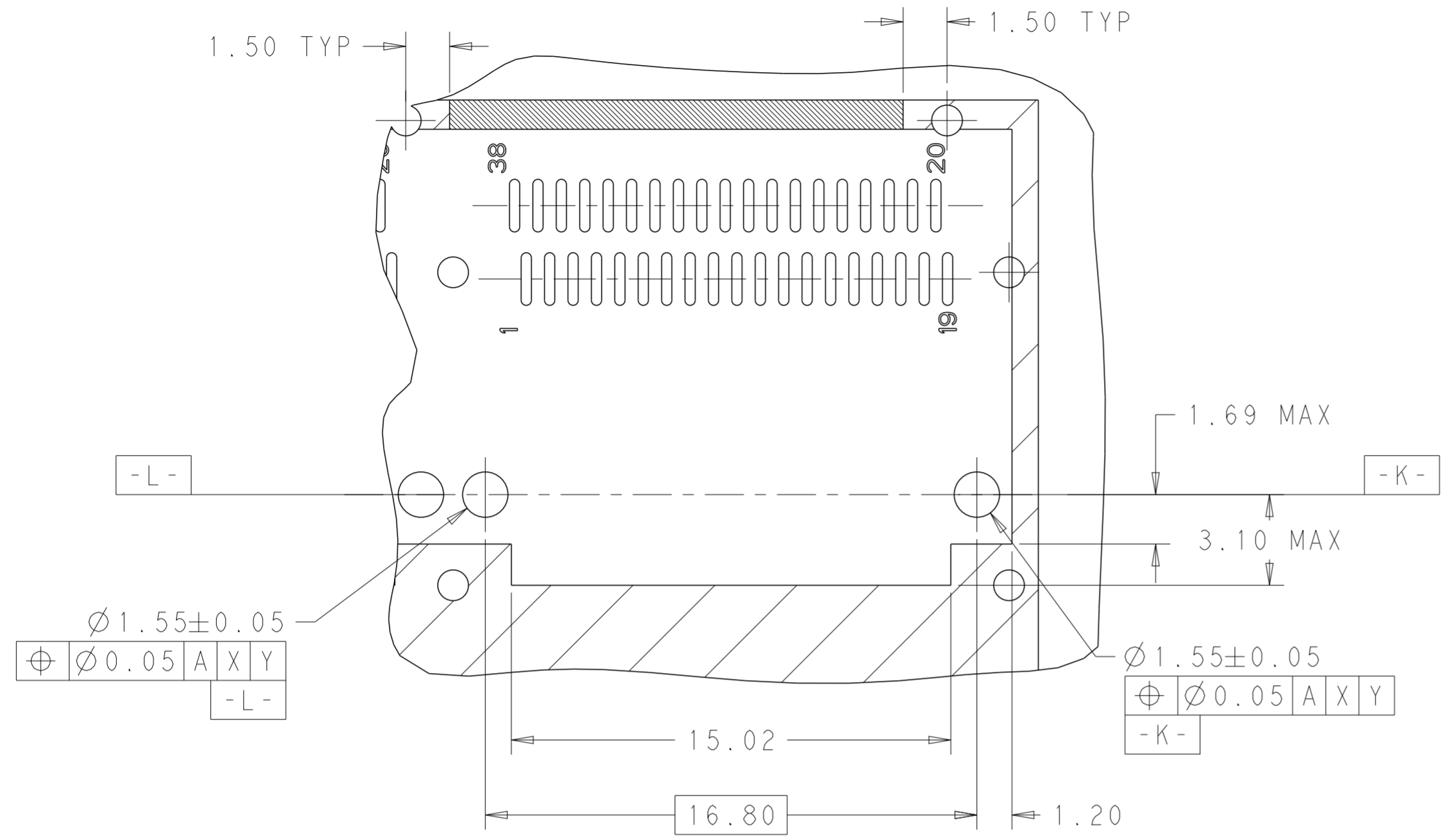

DETAIL A  
SCALE 6:1

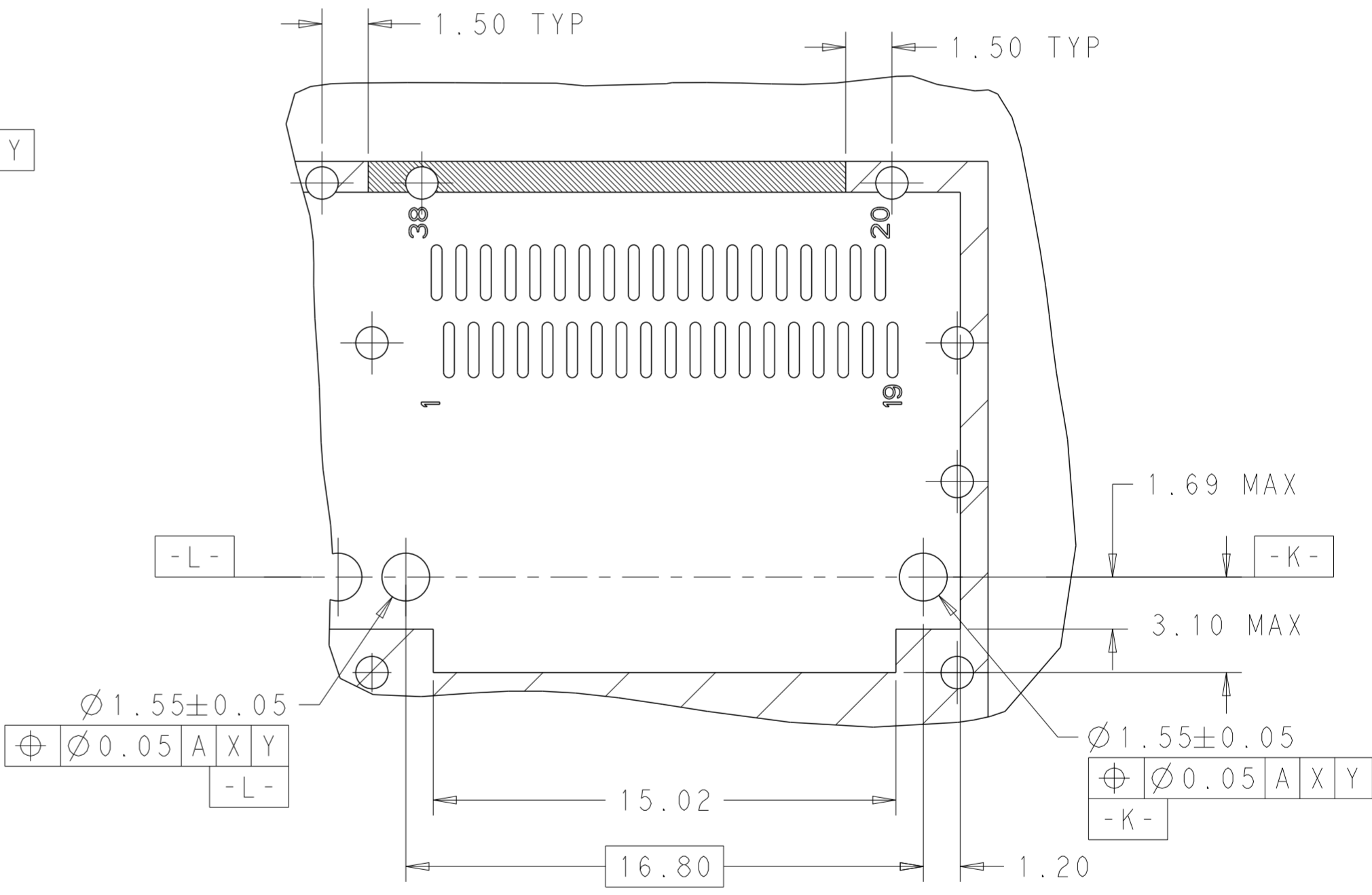

DETAIL B  
SCALE 6:1

THIS DRAWING IS A CONTROLLED DOCUMENT.		DWN BING LIU 15SEP2014	<b>STE</b> TE Connectivity	
		CHK JASON YANG 15SEP2014		
DIMENSIONS: mm		APVD SEAN HAN 26OCT2015	NAME RECEPTACLE CAGE ASSEMBLY WITH HEAT SINKS THRU BEZEL, 1X2, QSFP28	
TOLERANCES UNLESS OTHERWISE SPECIFIED: 0 PLC ± 1 PLC ±0.25 2 PLC ±0.2 3 PLC ± 4 PLC ± ANGLES ±		PRODUCT SPEC 108-19428	SIZE A200779	
MATERIAL SEE NOTES material_2		APPLICATION SPEC 114-32023	DRAWING NO C-2170812	
FINISH SEE NOTES finish_spec_2		WEIGHT -	RESTRICTED TO -	
		Customer Drawing	SCALE 1:1	SHEET 5 OF 5
			REV A1	