

# ioLogik R1200 Series

## RS-485 remote I/O



- > Dual RS-485 remote I/O with built-in repeater
- > Supports the installation of multi-drop communication parameters
- > Install communication parameters and upgrade firmware via USB
- > Upgrade firmware through an RS-485 connection
- > Wide operating temperature (-40 to 85°C) models available



### Introduction

The ioLogik R1200 smart RS-485 serial remote I/O devices are perfect for establishing a cost-effective, dependable, and easy-to-maintain process control remote I/O system. Serial remote I/O products offer process engineers the benefit of simple wiring, as they only require two wires to communicate with the controller and other RS-485 devices while adopting the EIA/TIA RS-485 communication protocol to transmit and receive data at high speed over long distances. In

addition to communication configuration by software or USB and dual RS-485 port design, Moxa's smart remote I/O devices eliminate the nightmare of extensive labor associated with the setup and maintenance of data acquisition and automation systems. Moxa also offers different I/O combinations, which provide greater flexibility and are compatible with every kind of application.

### ioLogik R1200 Series Selection Table

Models	I/O Combinations				
	Digital Inputs	Configurable DI/Os	Analog Inputs	Analog Outputs	Relay Outputs
ioLogik R1210	16	–	–	–	–
ioLogik R1212	8	8	–	–	–
ioLogik R1214	6	–	–	–	6
ioLogik R1240	–	–	8	–	–
ioLogik R1241	–	–	–	4	–

### ioLogik R1210 Specifications

#### Inputs and Outputs

**Digital Inputs:** 16 channels  
**Isolation:** 3k VDC or 2k Vrms

#### Digital Input

**Sensor Type:** Wet Contact (NPN or PNP), Dry Contact

**I/O Mode:** DI or Event Counter

#### Dry Contact:

- On: short to GND
- Off: open

#### Wet Contact (DI to COM):

- On: 10 to 30 VDC
- Off: 0 to 3 VDC

**Common Type:** 8 points per COM

**Counter Frequency:** 2.5 kHz

**Digital Filtering Time Interval:** Software Configurable

#### Power Requirements

**Power Consumption:** 154 ma @ 24 VDC

### ioLogik R1212 Specifications

#### Inputs and Outputs

**Digital Inputs:** 8 channels  
**Configurable DI/Os:** 8 channels  
**Isolation:** 3k VDC or 2k Vrms

#### Digital Input

**Sensor Type:** Wet Contact (NPN or PNP), Dry Contact

**I/O Mode:** DI or Event Counter

#### Dry Contact:

- On: short to GND
- Off: open

**Wet Contact (DI to COM):**

- On: 10 to 30 VDC
- Off: 0 to 3 VDC

**Common Type:** 8 points per COM

**Counter Frequency:** 2.5 kHz

**Digital Filtering Time Interval:** Software Configurable

**Digital Output**

**Type:** Sink

**I/O Mode:** DO or Pulse Output

**Pulse Output Frequency:** 5 kHz

**Over-voltage Protection:** 45 VDC

**Over-current Protection:** 2.6 A (4 channels @ 650 mA)

**Over-temperature Shutdown:** 175°C (typical), 150°C (min.)

**Current Rating:** 200 mA per channel

**Power Requirements**

**Power Consumption:** 187 ma @ 24 VDC

**ioLogik R1214 Specifications**

**Inputs and Outputs**

**Digital Inputs:** 6 channels

**Relay Outputs:** 6 channels

**Isolation:** 3k VDC or 2k Vrms

**Digital Input**

**Sensor Type:** Wet Contact (NPN or PNP), Dry Contact

**I/O Mode:** DI or Event Counter

**Dry Contact:**

- On: short to GND
- Off: open

**Wet Contact (DI to COM):**

- On: 10 to 30 VDC
- Off: 0 to 3 VDC

**Common Type:** 6 points per COM

**Counter Frequency:** 2.5 kHz

**Digital Filtering Time Interval:** Software Configurable

**Relay Output**

**Type:** Form A (N.O.) power relay

**Contact Current Rating:** Resistive load: 5 A @ 30 VDC, 250 VAC, 110 VAC

**Breakdown Voltage:** 500 VAC

**Relay On/Off Time:** 1500 ms (Max.)

**Initial Insulation Resistance:** 1000 M ohms (min.) @ 500 VDC

**Mechanical Endurance:** 5,000,000 operations

**Electrical Endurance:** 100,000 operations @ 5 A resistive load

**Contact Resistance:** 100 m ohms (max.)

**Pulse Output:** 0.3 Hz at rated load

**Note:** Ambient humidity must be non-condensing and remain between 5 and 95%. The relays of the ioLogik R1214 may malfunction when operating in high condensation environments below 0°C.

**Power Requirements**

**Power Consumption:** 207 ma @ 24 VDC

**ioLogik R1240 Specifications**

**Inputs and Outputs**

**Analog Inputs:** 8 channels

**Isolation:** 3k VDC or 2k Vrms

**Analog Input**

**Type:** Differential input

**Resolution:** 16 bits

**I/O Mode:** Voltage / Current

**Input Range:** 0 to 10 VDC, 0 to 20 mA, 4 to 20 mA (burn-out mode)

**Accuracy:**

±0.1% FSR @ 25°C

±0.3% FSR @ -10 and 60°C

±0.5% FSR @ -40 and 75°C

**Sampling Rate (all channels):** 12 Hz

**Input Impedance:** 10M ohms (min.)

**Built-in Resistor for Current Input:** 120 ohms

**Power Requirements**

**Power Consumption:** 216 ma @ 24 VDC

**ioLogik R1241 Specifications**

**Inputs and Outputs**

**Analog Outputs:** 4 channels

**Isolation:** 3k VDC or 2k Vrms

**Analog Output**

**Resolution:** 12 bits

**Output Range:** 0 to 10 VDC, 4 to 20 mA

**Voltage Output:** 10 mA (max.)

**Accuracy:**

±0.1% FSR @ 25°C

±0.3% FSR @ -40 and 75°C

**Load Resistor:** Internal register: 400 ohms

**Note:** 24 V of external power required when loading exceeds 1000 ohms.

**Power Requirements**

**Power Consumption:** 343 ma @ 24 VDC

**Common Specifications**

**Serial Communication**

**Interface:** RS-485-2w: Data+, Data-, GND (5-contact terminal block for two serial port)

**Serial Line Protection:**

ESD Protection: 15 kV

Surge Protection: 1 kV

**Serial Communication Parameters**

**Parity:** None, Even, Odd (default = None)

**Data Bits:** 8

**Stop Bits:** 1, 2 (default = 1)

**Baudrate:** 1200 to 921.6 kbps (default = 9600)

**High/Low Resistor for RS-485:** 1 kΩ, 150 kΩ

**Protocols:**

Modbus RTU

**Physical Characteristics**

**Wiring:** I/O cable max. 16 AWG

**Dimensions:** 27.8 x 124 x 84 mm (1.09 x 4.88 x 3.31 in)

**Environmental Limits**

**Operating Temperature:**

Standard Models: -10 to 75°C (14 to 167°F)

Wide Temp. Models: -40 to 85°C (-40 to 185°F)

**Storage Temperature:** -40 to 85°C (-40 to 185°F)

**Ambient Relative Humidity:** 5 to 95% (non-condensing)

### Standards and Certifications

**Safety:** UL 508

**EMI:**

EN 55022, EN 61000-3-2, EN 61000-3-3, FCC Part 15 Subpart B Class A

**EMS:**

EN 55024, EN 61000-4-2 (ESD) Level 3, EN 61000-4-5 (Surge) Level 2, IEC 61000-4, IEC 61000-6

**Shock:** IEC 60068-2-27

**Freefall:** IEC 60068-2-32

**Vibration:** IEC 60068-2-6

### Warranty

**Warranty Period:** 5 years (excluding the ioLogik R1214)

**Details:** See [www.moxa.com/warranty](http://www.moxa.com/warranty)

### Dimensions

Unit: mm (inch)

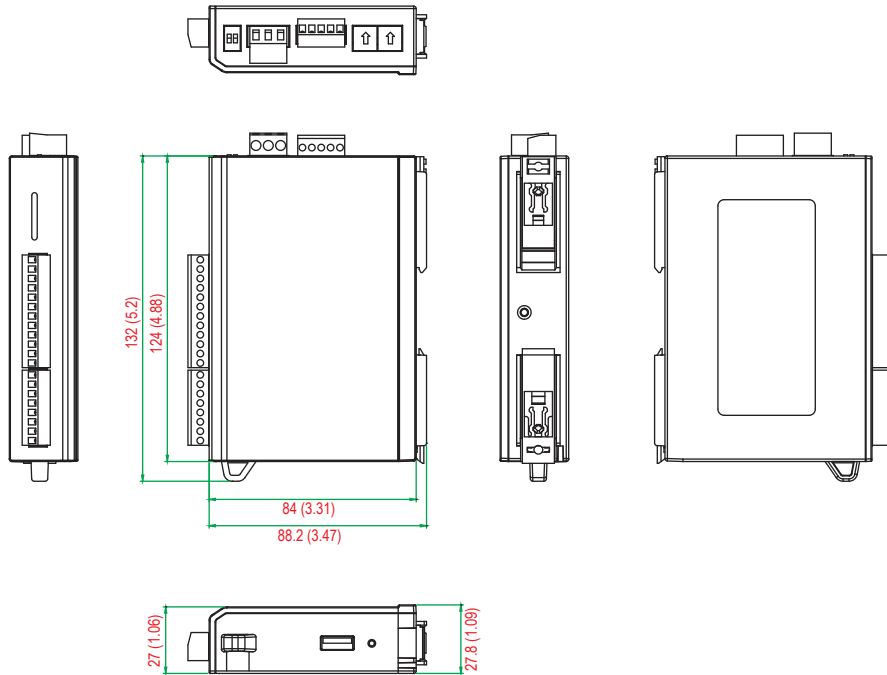

### Ordering Information

#### Available Models

- ioLogik R1210:** RS-485 remote I/O, 16 DIs, -10 to 75°C operating temperature
- ioLogik R1210-T:** RS-485 remote I/O, 16 DIs, -40 to 85°C operating temperature
- ioLogik R1212:** RS-485 remote I/O, 8 DIs, 8 DI/Os, -10 to 75°C operating temperature
- ioLogik R1212-T:** RS-485 remote I/O, 8 DIs, 8 DI/Os, -40 to 85°C operating temperature
- ioLogik R1214:** RS-485 remote I/O, 6 DIs, 6 Relays, -10 to 75°C operating temperature
- ioLogik R1214-T:** RS-485 remote I/O, 6 DIs, 6 Relays, -40 to 85°C operating temperature
- ioLogik R1240:** RS-485 remote I/O, 8 AIs, -10 to 75°C operating temperature
- ioLogik R1240-T:** RS-485 remote I/O, 8 AIs, -40 to 85°C operating temperature
- ioLogik R1241:** RS-485 remote I/O, 4 AOs, -10 to 75°C operating temperature
- ioLogik R1241-T:** RS-485 remote I/O, 4 AOs, -40 to 85°C operating temperature

#### Package Checklist

- ioLogik R1200
- Documentation and software CD
- Quick installation guide (printed)