



TeraRanger Evo Mini

Mini price, great performance

The smallest and lightest addition to the TeraRanger Evo sensor family provides versatile performance and value for money! Measure distance, detect movements, monitor stock levels and recognize simple gestures - just some of the amazing things you can do with Terabee's mini, close-range distance sensor!



ROS

Key features

- Time-of-Flight technology
- Great price vs performance ratio
- Optimized for indoor distance measurements - 0.03 m to 3.3 m
- Select from 1, 2 or 4 pixel modes
- Lightweight & small size design - only 9 grams (including backboard)
- Low power consumption - suitable to battery powered IoT projects
- USB, UART and I2C clip-on, interchangeable, interfaces
- Compatible with Arduino, Raspberry Pi and ROS

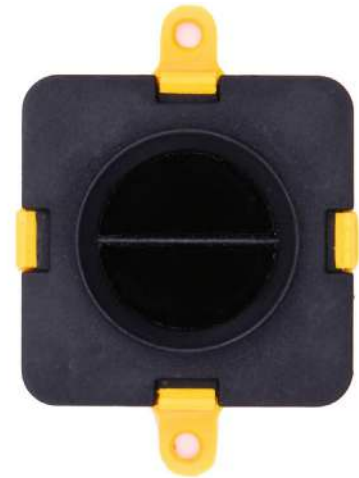

Enabler for the following applications

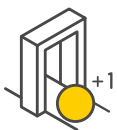

Detecting direction of movement and counting



Basic gesture recognition



Stock level monitoring (bins, shelves)



Anti-collision for mobile robotics



Precision-landing for indoor drones



Distance measurement applications

Technical specifications

Product code	TR-EVO-MINI-USB/TR-EVO-MINI-I2C
Performance	
Detection Principle	Infrared Time-of-Flight
Light Source Wavelength	940 nm
Use Environment	Indoors
Repetability	< 5 mm
Output Distance Resolution	1 mm
Field of View	27°
Projected Reception Area	48 cm x 48 cm @ 1 m
Operation	Pixel (px) modes: 1px, 2px, 4px (2x2) Range modes: short-range, long-range
Range	
Accuracy	Please see "Performance Matrix" table for more details
Update Rate	
Electronics	
Supply Voltage V_{DC}	5VDC +/-5%
Current Consumption Average	50mA
Initialization Time	< 1 s
Communication	
Serial interfaces	USB 2.0 Micro-B UART, +3.3V level, 115200,8,1, None I2C, +3.3V level, 400 kHz
Visual Notification	2 x LEDs (built-in backboard)
Mechanical data	
Dimensions	42 x 30 x 13 mm (incl. backboard)
Weight	9 g (incl. backboard)
Operating Temperature	-20°C to 75°C
Housing Material	ABS
Mounting Style	2 holes for M2 screws
Type of Connection	USB Backboard: USB 2.0 Micro-B I2C/UART Backboard: DF13-7p connector Hub Evo Backboard for use with TeraRanger Hub Evo
Conformity	
Reference Standard	CE, RoHS

Back-panel installation



Front-panel installation



Dimensions

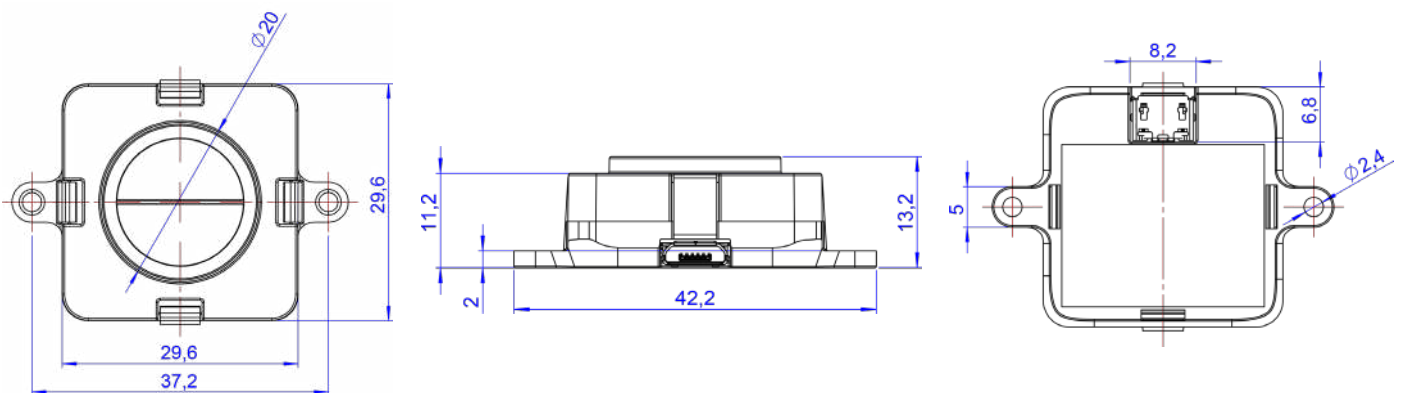

Performance matrix

Range mode	Short-Range			Long-Range		
Pixel mode	1px mode	2px mode	4px mode	1px mode	2px mode	4px mode
Range	0.03m to 1.35m	0.03m to 1.35m	0.03m to 1.35m	0.03m to 3.3m	0.03m to 2.3m	0.03m to 1.65m
Accuracy	Up to +/-1.5cm	Up to +/-1.5cm	Up to +/- 2cm	Up to +/- 2cm	Up to +/-1.5cm	Up to +/- 3cm
Update Rate	Fixed 40Hz	Fixed 13Hz	Fixed 6Hz	Fixed 20Hz	Fixed 8Hz	Fixed 4Hz

Specifications are derived from tests in controlled conditions (target with 80% diffuse reflectivity, indoor fluorescent lighting, ambient temperature around 25°C). Note that bright sunlight, target surface reflectivity and other variables can affect sensor performance

Pixel modes

1 px mode

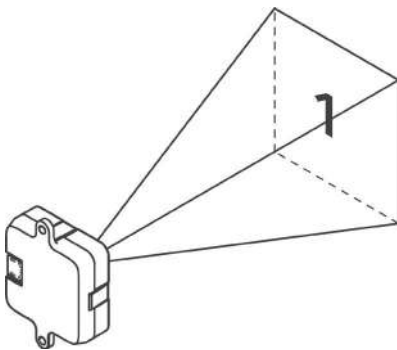

2 px mode

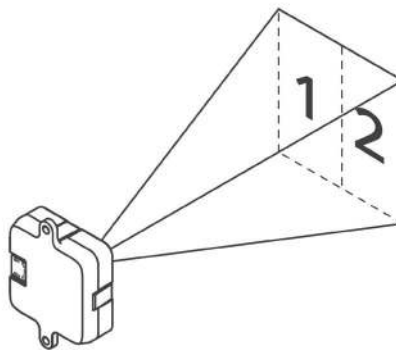

4 px mode

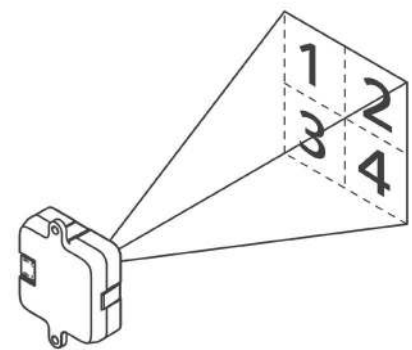

Communication interfaces

Interface	Short-Range			Long-Range		
	1px mode	2px mode	4px mode	1px mode	2px mode	4px mode
USB	●	●	●	●	●	●
UART*	●	●	●	●	●	●
I2C*	●			●		
Hub Evo				●		

*Please note that UART and I2C data communication is supported by the same interface backboard

Recommended modes per application

Application	Short-Range			Long-Range		
	1 px mode	2 px mode	4 px mode	1 px mode	2 px mode	4 px mode
Counting applications, movement detection		●	●		●	●
Basic gesture recognition		●				
Stock level monitoring				●	●	●
Anti-collision, mobile robots	●			●		
Robot positioning, guidance	●			●		
Precision-landing for drones				●		
Distance measurement applications	●	●	●	●	●	●