

PART NUMBER	REVISION	DESCRIPTION	FEED TYPE
2150488-1	B	FINE CRIMP HEIGHT ADJUST	MECHANICAL
2150488-2	B	FINE CRIMP HEIGHT ADJUST	PNEUMATIC
7-2150488-1	B	MECHANICAL AND CRIMP TOOLING KIT	MECHANICAL
7-2150488-2	B	PNEUMATIC AND CRIMP TOOLING KIT	PNEUMATIC
7-2150488-7	A	CRIMP TOOLING KIT	-

ATLANTIC VERSION TERMINATOR INTERFACE ADAPTER

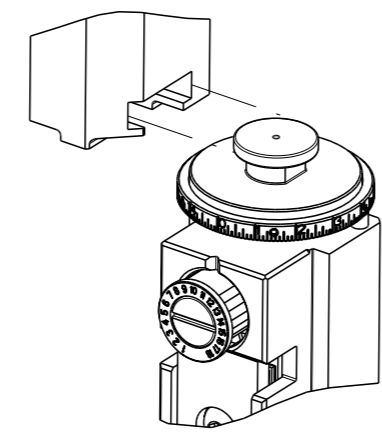

APPLICATOR DATA		
CRIMP	SIZE	TYPE
WIRE	2.79 mm [.110]	F
INSUL	3.86 mm [.152]	F
APPL INSTRUCTIONS 408-35043		

TERMINAL DATA: LEAR TERMINAL		LEAR CRIMP SPECIFICATION	
TERMINAL NAME: RECEPTACLE, 6.3 mm FASTON			
WIRE STRIP LENGTH 6.00-6.00 mm [.236-.236 IN]		INSULATION DIAMETER RANGE Ø2.20-3.00 mm [.087-.118 IN]	
TERMINAL APPLICATION SPECIFICATION 25733 Rev 12			
TERMINALS APPLIED			
TE TERMINAL	LEAR TERMINAL	TE TERMINAL	LEAR TERMINAL
1572648-1	25733.201.011	1572648-5	25733.123.242
1572648-2	25733.123.211	1572648-6	25733.201.004
1572648-3	25733.417.031	1572648-7	25733.201.042
1572648-4	25733.123.204		

WIRE SIZE	CRIMP HEIGHT mm [INCH]	CRIMP HEIGHT REFERENCE SETTING
2.50mm2	2.05 +/- 0.05 [.081 +/- .002]	5.6
1.50mm2	1.75 +/- 0.05 [.069 +/- .002]	8.9

- 1 RECOMMENDED SPARE PARTS
- 2 REFER TO SUPPLIED INSTRUCTION SHEET FOR CLEANING, LUBRICATION AND STORAGE OF APPLICATOR.
- 3 APPLY PART NUMBER 1-23419-5 LOCTITE TO THREADS OF ITEMS 180. APPLY PART NUMBER 2-23419-6 LOCTITE TO THREADS OF ITEM 242.
- 4 CRIMP HEIGHT REFERENCE SETTING WAS THE SETTING USED WHEN THE APPLICATOR WAS QUALIFIED AT THE FACTORY. ADJUSTMENT MAY BE NECESSARY WHEN RUNNING APPLICATOR IN THE FIELD.
- 5 TERMINAL LUBRICANT IS RECOMMENDED.
- 6. UNLESS SPECIFIED OTHERWISE TORQUE VALUES SHALL BE USED PER DOCUMENT, 101-35000.

***WARNING**
ON INSTALLATION, SET WIRE DISC TO CRIMP HEIGHT REFERENCE SETTING FOR LARGEST WIRE SIZE. CRIMP HEIGHT REFERENCE SETTINGS GREATER THAN THE VALUE SHOWN MAY CAUSE DAMAGE TO THE CRIMP TOOLING, REFER TO THE INSTRUCTION SHEET FOR PROPER SETUP AND ADJUSTMENTS.

ATLANTIC VERSION
Shown on sheets 1 of 4 & 2 of 4
(Pacific version shown on sheets 3 of 4 & 4 of 4)

LOC	DIST	REVISIONS					
		P	LY#	DESCRIPTION	DATE	OWN	APVD
A	66	1		ORIGINAL	16SEP2014	GH	TE
		A		RELEASED	23OCT2014	GH	TE
		A1		ECR-16-014728	18OCT2016	RS	LZ
		B		ECR-19-009661	20JUN2019	MZ	YY

-	1	-	1	-	2119640-1	PUSH ROD, AIR FEED	250
-	1	-	1	-	1803259-1	BUSHING, FLANGED	249
-	1	-	1	-	2119641-1	FEED CAM, AIR FEED	248
-	1	1	1	1	2119082-3	CAM, SNAIL, INSULATION ADJUSTMENT	244
-	1	1	1	1	2079764-1	WASHER, WAVE SPRING, CREST-TO-CREST	243
-	1	1	1	1	2119083-1	RETAINER, INSULATION DIAL	242
-	-	-	-	-	2119580-1	MECHANICAL FEED ASSEMBLY	239
-	1	-	1	-	2063440-1	AIR FEED MODULE	238
-	1	1	1	1	1-1976055-3	STANDOFF, HOLD-DOWN	180
-	1	1	1	1	6-993111-6	PIN, SLOTTED SPRING 3.0 X 14.0	177
-	1	1	1	1	8-22280-7	SPRING, COMPRESSION	176
-	1	1	1	1	1752353-2	GUIDE PIN,HOLDDOWN	175
-	1	1	1	1	1901680-2	GUIDE PIN,HOLDDOWN	174
-	2	-	2	-	21045-3	RING, RETAIN, EXTERN, 3/16 CRESCENT	172
-	REF	REF	REF	REF	994970-2	COUNTER, MAGNETIC	164
-	1	-	1	-	240638-1	SPRING, FEED FINGER	163
-	1	-	1	-	3-23627-7	PIN, RETAIN, GRVD, 3/16 X .854	137
-	1	1	1	1	2119955-2	ASSY, LUBRICATOR, END FEED	84
-	1	1	1	1	455888-6	SPACER, CRIMPER	82
-	1	1	1	1	2119791-9	DEPRESSOR, WIRE	73
-	1	1	1	1	1803607-2	DOCUMENTATION PACKAGE	71
-	2	2	2	2	2-18032-2	SCR, SET, FLT PNT, M3 X 10.0	70
-	1	1	1	1	2119740-1	TAG, IDENTIFICATION	67
-	2	2	2	2	2168078-1	SCREW, DRIVE, RH, RoHS, 2 x .188	66
-	1	1	1	1	1901681-1	HOLDDOWN, TERMINAL	65
-	2	2	2	2	2168400-5	SHCS, LOW HEAD, RoHS, M4 X 20	64
-	1	1	1	1	2168083-2	SCR, SKT HD CAP, RoHS, M4 X 8.0	60
-	-	1	-	-	5-18022-5	SCR, HEX HD CAP, M4 X 6.0	59
-	-	1	-	-	2063961-1	FEED FINGER	58
-	3	3	3	3	2168400-4	SHCS, LOW HEAD, RoHS, M4 X 8	57
-	2	2	2	2	2168083-2	SCR, SKT HD CAP, RoHS, M4 X 8.0	56
-	2	2	2	2	5018030-1	NUT, HEX, REG, RoHS, M3	54
-	2	2	2	2	986965-8	NUT, LOCK, HEX, TORQUE (M4)	53
-	1	1	1	1	1-5018030-0	NUT, HEX, REG, RoHS, M3.5	52
-	1	-	1	-	2119792-2	PAWL, EF, AIR	51
-	1	2	1	2	18023-9	SCR, SKT HD CAP M4 X 6.0	49
-	-	1	-	-	2119652-1	FEED CAM, PRE FEED	48
-	-	1	-	-	2119653-1	FEED CAM, POST FEED	47
-	1	1	1	1	2119655-5	APPLICATOR BASIC ASSEMBLY, EF	46
-	1	1	1	1	1803517-1	RAM ASSEMBLY, EF ATLANTIC	44
-	1	1	1	1	1803602-1	SCR, BHSC, RoHS (M8 X 25)	41
-	7	7	7	7	1-18028-2	WASHER, FLAT, REG M4	33
-	2	2	2	2	2168083-9	SCR, SKT HD CAP, RoHS, M4 X 20	31
-	2	2	2	2	2168083-2	SCR, SKT HD CAP, RoHS, M4 X 8.0	29
-	1	1	1	1	240639-1	STRIPPER (MACHINING)	27
-	2	2	2	2	1-2168083-5	SCR, SKT HD CAP, RoHS, M4 X 30	25
-	1	1	1	1	1752371-5	PLATE, STRIP GUIDE	24
-	1	1	1	1	240825-3	PLATE, STRIP HOLD DOWN	23
-	2	2	2	2	2-22281-3	SPRING, COMPRESSION	22
-	1	1	1	1	1803292-4	DRAG	20
-	2	2	2	2	1901259-5	GUIDE, LOWER STRIP	18
-	4	4	4	4	1-2079383-1	SCR, BHSC, RoHS (M6 X 12)	17
-	1	1	1	1	1752360-1	SPACER,HOLD-DOWN	13
-	1	1	1	1	240644-9	PLATE, REAR SHEAR	11
-	-	-	-	-	-	-	10
-	1	1	1	1	2-690482-9	PLATE, FRONT SHEAR	9
1	2	2	1	1	6-1803001-0	ANVIL, COMBINATION, END FEED	8
-	1	1	1	1	1-2217206-3	BLADE, SLUG	7
-	1	1	1	1	1803203-1	BLOCK, FRONT DEPRESSOR	6
-	1	1	1	1	7-240641-1	SPACER	5
-	1	1	1	1	4-238011-2	BLOCK, CRIMPER SPACER	4
1	2	2	1	1	6-1633962-4	CRIMPER, INSULATION F PREMIUM	3
-	1	1	1	1	455888-8	SPACER, CRIMPER	2
1	2	2	1	1	1-456408-9	CRIMPER, WIRE PREMIUM	1
-	77-72-71	-	2	-	PART NO	DESCRIPTION	ITEM NO

DIMENSIONS:		TOLERANCES UNLESS OTHERWISE SPECIFIED:		DRAWN		DATE	
mm	0 PLC ±	1 PLC ±	2 PLC ±	HOFFNER	15SEP2014	TE Connectivity	16SEP2014
	3 PLC ±	4 PLC ±	ANGLES ±	T. ELBIN	16SEP2014	Harrisburg, PA 17105-3608	
	FINISH			APVD	16SEP2014		
MATERIAL				NAME		Ocean End Feed Applicator	
				APPLICATION SPEC		SIZE	CAGE CODE DRAWING NO
				WEIGHT		A1	00779 ©=2150488
				Customer Accessible Production Drawing	SCALE	1:1	SHEET 1 OF 4 REV B

LOC		DIST		REVISIONS			
A	66	P	LY#	DESCRIPTION	DATE	OWN	APVD
		-		SEE SHEET 1			

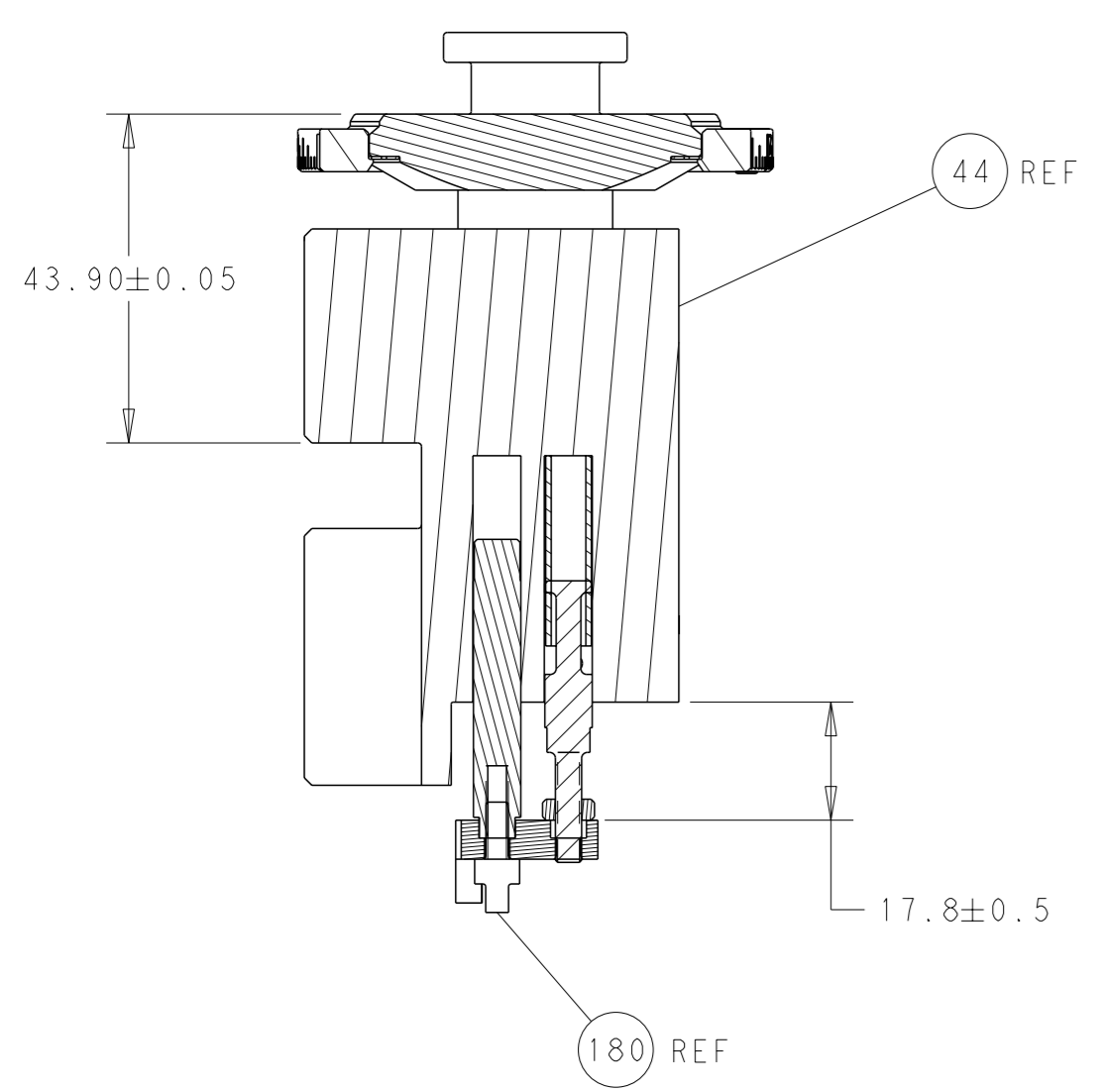

RAM AND HOLDDOWN SET-UP

FEED TYPE
MECHANICAL

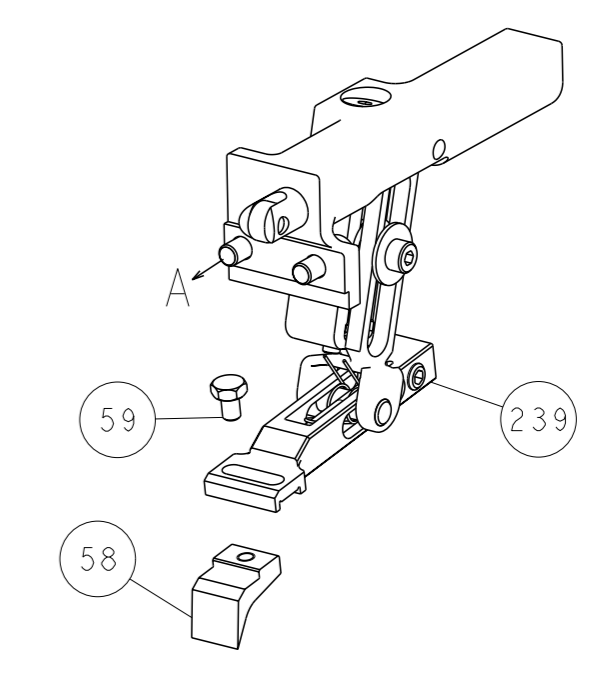

PNEUMATIC

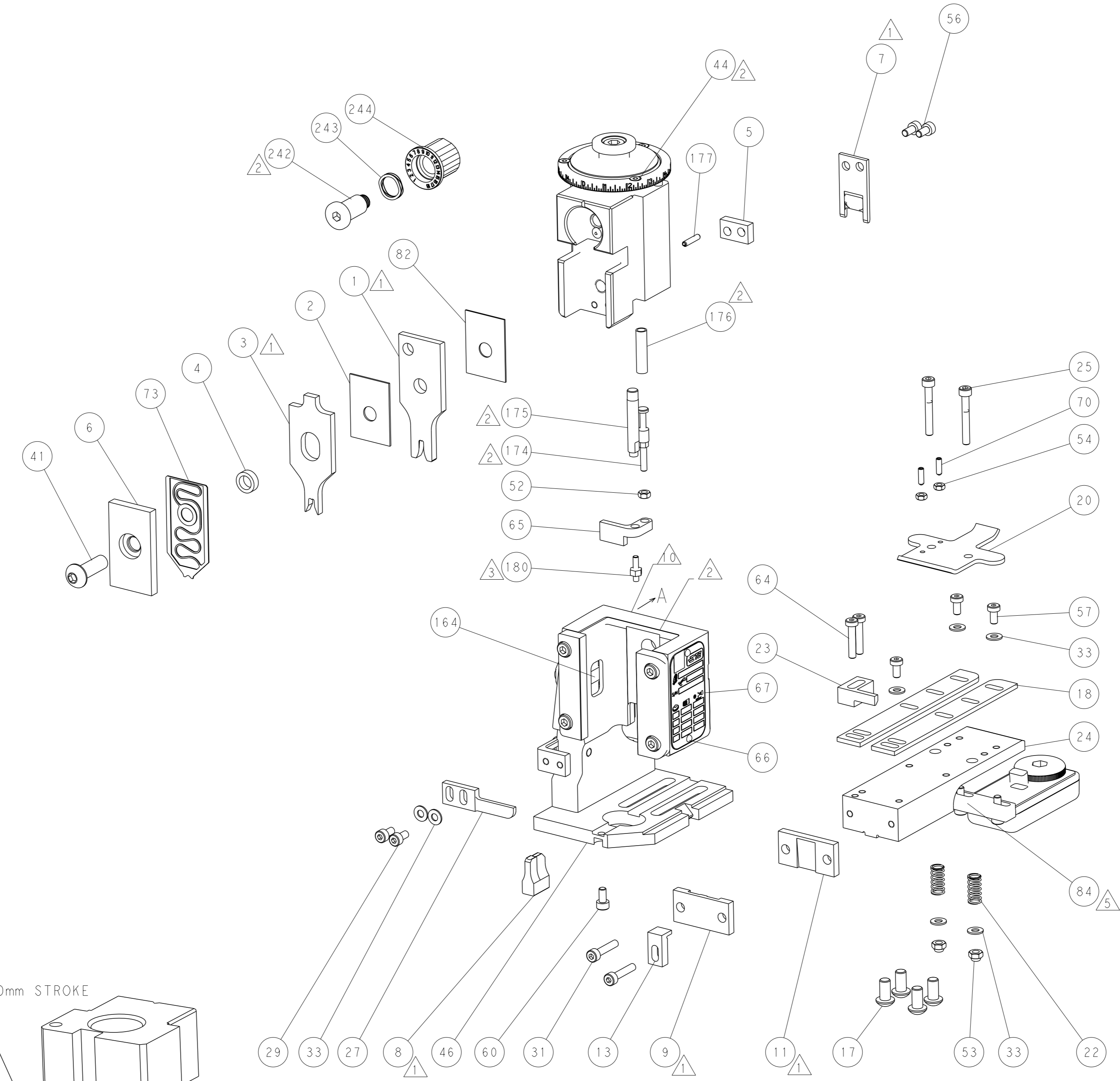
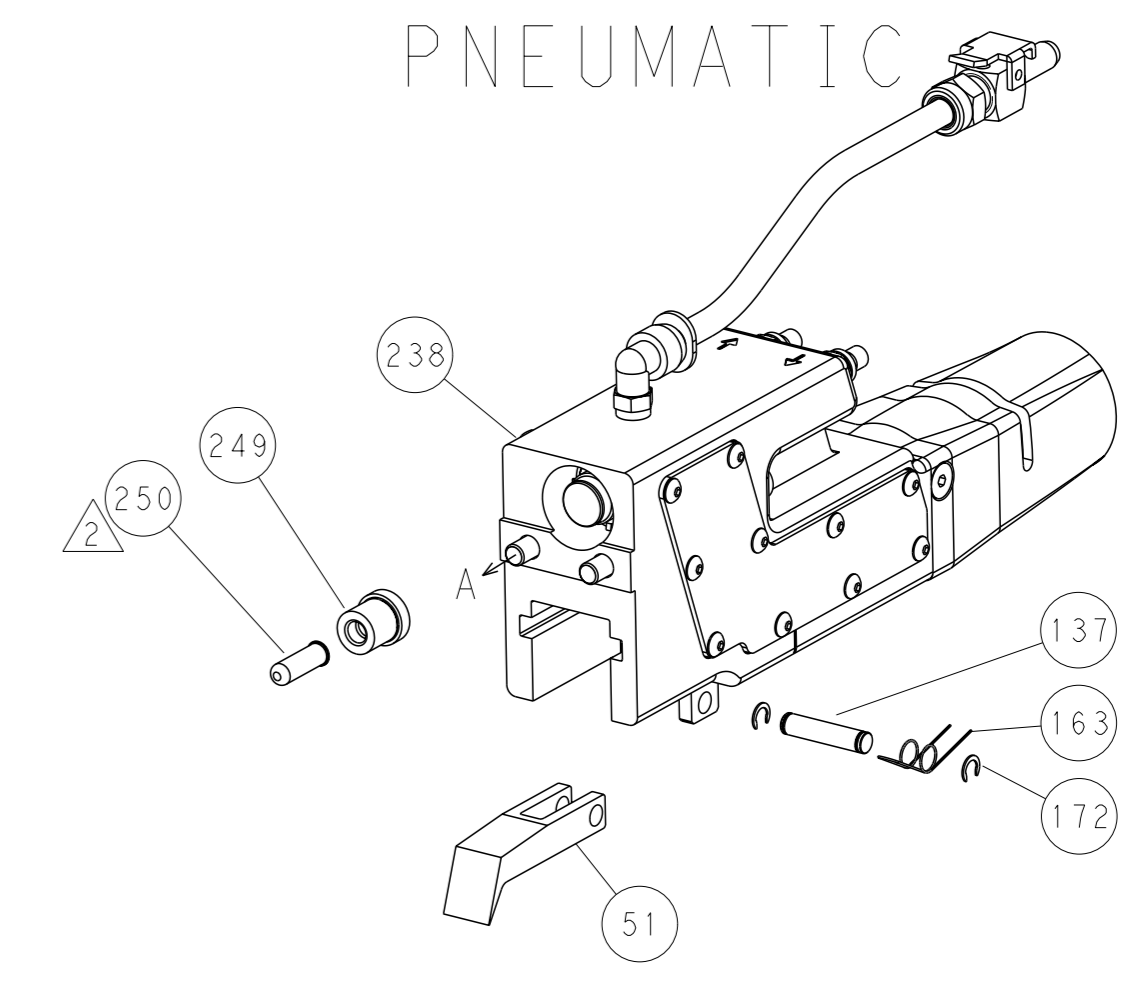

CAM POSITIONS

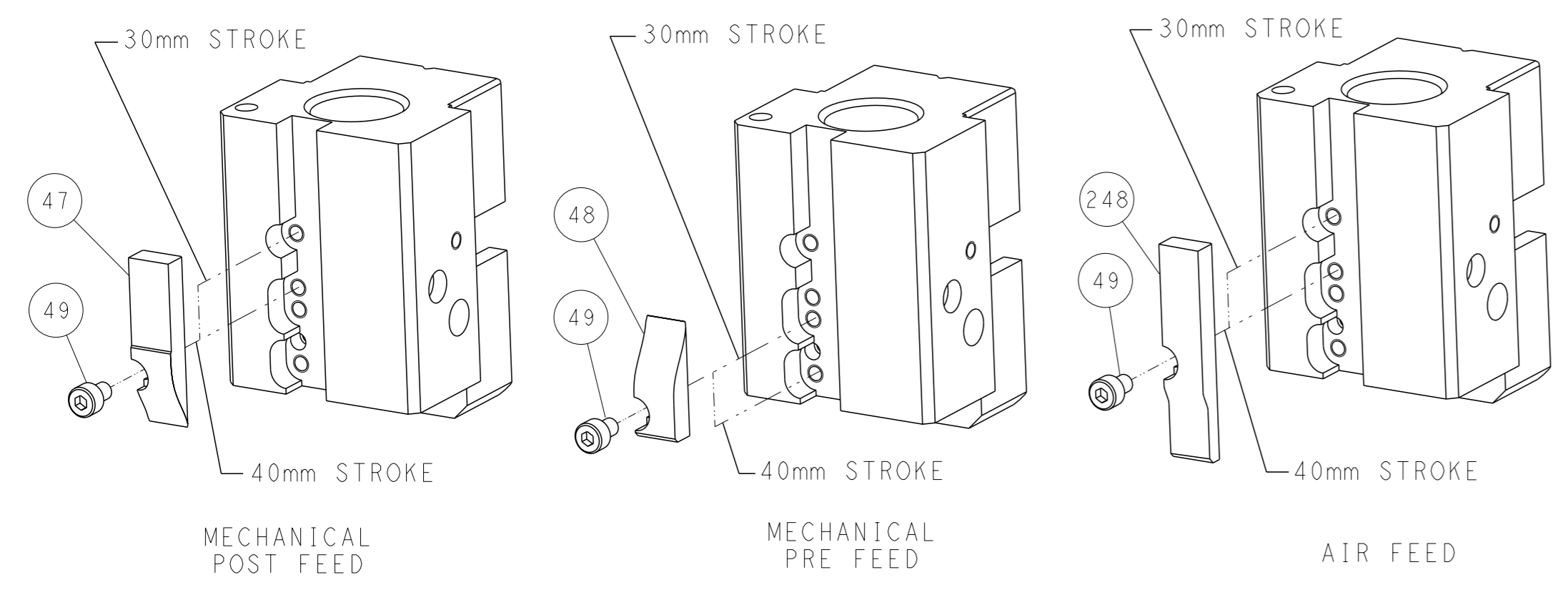

ATLANTIC VERSION
 Shown on sheets 1 of 4 & 2 of 4
 (Pacific version shown on sheets 3 of 4 & 4 of 4)

<small>THIS DRAWING IS A CONTROLLED DOCUMENT FOR TYCO ELECTRONICS CORPORATION. IT IS SUBJECT TO CHANGE AND THE USER'S RESPONSIBILITY TO OBTAIN THE LATEST REVISION SHOULD BE CONTACTED FOR THE LATEST REVISION.</small>		OWN: HOFFNER 15SEPT2014 CHG: T. ELBIN 16SEPT2014 APVD: T. ELBIN 16SEPT2014	TE Connectivity Harrisburg, PA 17105-3608
DIMENSIONS: mm TOLERANCES UNLESS OTHERWISE SPECIFIED: 0 PLC ± 1 PLC ± 2 PLC ± 3 PLC ± 4 PLC ± ANGLES FINISH ±		NAME: Ocean End Feed Applicator SIZE: A1 CAGE CODE: 00779 DRAWING NO: C=2150488	RESTRICTED TO: - SCALE: 1:1 SHEET: 2 of 4 REV: B
MATERIAL: - FINISH: -		WEIGHT: - APPLICATION SPEC: - CUSTOMER ACCESSIBLE PRODUCTION DRAWING	

PART NUMBER	REVISION	DESCRIPTION	FEED TYPE
2-2150488-1	B	FINE CRIMP HEIGHT ADJUST	MECHANICAL
2-2150488-2	B	FINE CRIMP HEIGHT ADJUST	PNEUMATIC
7-2150488-7	A	CRIMP TOOLING KIT	-

PACIFIC VERSION TERMINATOR INTERFACE ADAPTER

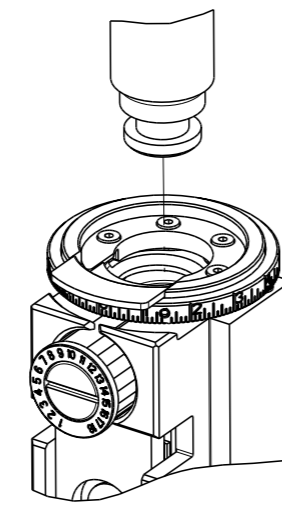

APPLICATOR DATA		
CRIMP	SIZE	TYPE
WIRE	2.79 mm [1.101]	F
INSUL	3.86 mm [1.521]	F
APPL INSTRUCTIONS 408-35043		

TERMINAL DATA: LEAR TERMINAL		LEAR CRIMP SPECIFICATION	
TERMINAL NAME: RECEPTACLE, 6.3 mm FASTON			
WIRE STRIP LENGTH 6.00-6.00 mm [1.236-.236 IN]		INSULATION DIAMETER RANGE Ø2.20-3.00 mm [1.087-.118 IN]	
TERMINAL APPLICATION SPECIFICATION	25733 Rev 12	-	-
TERMINALS APPLIED			
TE TERMINAL	LEAR TERMINAL	TE TERMINAL	LEAR TERMINAL
1572648-1	25733.201.011	1572648-5	25733.123.242
1572648-2	25733.123.211	1572648-6	25733.201.004
1572648-3	25733.417.031	1572648-7	25733.201.042
1572648-4	25733.123.204		

WIRE SIZE	CRIMP HEIGHT mm [INCH]	CRIMP HEIGHT REFERENCE SETTING
2.50mm2	2.05+/-0.05 [1.081+/-0.021]	5.6
1.50mm2	1.75+/-0.05 [1.069+/-0.021]	8.9



- 1 RECOMMENDED SPARE PARTS
- 2 REFER TO SUPPLIED INSTRUCTION SHEET FOR CLEANING, LUBRICATION AND STORAGE OF APPLICATOR.
- 3 APPLY PART NUMBER 1-23419-5 LOCTITE TO THREADS OF ITEMS 180. APPLY PART NUMBER 2-23419-6 LOCTITE TO THREADS OF ITEM 242.
- 4 CRIMP HEIGHT REFERENCE SETTING WAS THE SETTING USED WHEN THE APPLICATOR WAS QUALIFIED AT THE FACTORY. ADJUSTMENT MAY BE NECESSARY WHEN RUNNING APPLICATOR IN THE FIELD.
- 5 TERMINAL LUBRICANT IS RECOMMENDED.
- 6. UNLESS SPECIFIED OTHERWISE TORQUE VALUES SHALL BE USED PER DOCUMENT, 101-35000.

***WARNING**
ON INSTALLATION, SET WIRE DISC TO CRIMP HEIGHT REFERENCE SETTING FOR LARGEST WIRE SIZE. CRIMP HEIGHT REFERENCE SETTINGS GREATER THAN THE VALUE SHOWN MAY CAUSE DAMAGE TO THE CRIMP TOOLING, REFER TO THE INSTRUCTION SHEET FOR PROPER SETUP AND ADJUSTMENTS.

PACIFIC VERSION
Shown on sheets 3 of 4 & 4 of 4
(Atlantic version shown on sheets 1 of 4 & 2 of 4)

LOC	DIST	REVISIONS					
		P	LY#	DESCRIPTION	DATE	OWN	APVD
A	66	-	-	SEE SHEET 1	-	-	-

-	1	-	2119640-1	PUSH ROD, AIR FEED	250	
-	1	-	1803259-1	BUSHING, FLANGED	249	
-	1	1	2119082-3	CAM, SNAIL, INSULATION ADJUSTMENT	244	
-	1	1	2079764-1	WASHER, WAVE SPRING, CREST-TO-CREST	243	
3	-	1	2119083-1	RETAINER, INSULATION DIAL	242	
-	-	1	2119580-1	MECHANICAL FEED ASSEMBLY	239	
-	1	-	2063440-1	AIR FEED MODULE	238	
-	4	4	2079383-9	SCR, BHSC, RoHS (M6 X 20)	186	
3	-	1	1-1976055-3	STANDOFF, HOLD-DOWN	180	
-	1	1	6-993111-6	PIN, SLOTTED SPRING 3.0 X 14.0	177	
-	1	1	8-22280-7	SPRING, COMPRESSION	176	
-	1	1	1752353-2	GUIDE PIN,HOLDDOWN	175	
-	1	1	1901680-2	GUIDE PIN,HOLDDOWN	174	
-	2	-	21045-3	RING, RETAIN, EXTERN, 3/16 CRESCENT	172	
-	REFREF	-	994970-2	COUNTER, MAGNETIC	164	
-	1	-	240638-1	SPRING, FEED FINGER	163	
-	1	-	2119641-2	FEED CAM, AIR FEED	152	
-	1	1	2168083-8	SCR, SKT HD CAP, RoHS, M4 X 16	144	
-	-	1	2119653-2	FEED CAM, POST FEED	142	
-	1	1	2119655-6	APPLICATOR BASIC ASSEMBLY, EF	141	
-	1	1	1803518-1	RAM ASSEMBLY, EF PACIFIC	140	
-	1	-	3-23627-7	PIN, RETAIN, GRVD, 3/16 X .854	137	
5	-	1	2119955-2	ASSY, LUBRICATOR, END FEED	84	
-	1	1	455888-6	SPACER, CRIMPER	82	
-	1	1	2119791-9	DEPRESSOR, WIRE	73	
-	1	1	1803607-2	DOCUMENTATION PACKAGE	71	
-	2	2	2-18032-2	SCR, SET, FLT PNT, M3 X 10.0	70	
-	1	1	2119740-1	TAG, IDENTIFICATION	67	
-	2	2	2168078-1	SCREW, DRIVE, RH, RoHS, 2 x .188	66	
-	1	1	1901681-1	HOLDDOWN, TERMINAL	65	
-	2	2	2168400-5	SHCS, LOW HEAD, RoHS, M4 X 20	64	
-	-	1	5-18022-5	SCR, HEX HD CAP, M4 X 6.0	59	
-	-	1	2063961-1	FEED FINGER	58	
-	3	3	2168400-4	SHCS, LOW HEAD, RoHS, M4 X 8	57	
-	2	2	2168083-2	SCR, SKT HD CAP, RoHS, M4 X 8.0	56	
-	2	2	5018030-1	NUT, HEX, REG, RoHS, M3	54	
-	2	2	986965-8	NUT, LOCK, HEX, TORQUE (M4)	53	
-	1	1	1-5018030-0	NUT, HEX, REG, RoHS, M3.5	52	
-	1	-	2119792-2	PAWL, EF, AIR	51	
-	1	2	18023-9	SCR, SKT HD CAP M4 X 6.0	49	
-	-	1	2119652-1	FEED CAM, PRE FEED	48	
-	1	1	1803602-1	SCR, BHSC, RoHS (M8 X 25)	41	
-	7	7	1-18028-2	WASHER, FLAT, REG M4	33	
-	2	2	2168083-9	SCR, SKT HD CAP, RoHS, M4 X 20	31	
-	2	2	2168083-2	SCR, SKT HD CAP, RoHS, M4 X 8.0	29	
-	1	1	240639-1	STRIPPER (MACHINING)	27	
-	2	2	1-2168083-5	SCR, SKT HD CAP, RoHS, M4 X 30	25	
-	1	1	1752371-5	PLATE, STRIP GUIDE	24	
-	1	1	240825-3	PLATE, STRIP HOLD DOWN	23	
-	2	2	2-22281-3	SPRING, COMPRESSION	22	
-	1	1	1803292-4	DRAG	20	
-	2	2	1901259-5	GUIDE, LOWER STRIP	18	
-	1	1	1752360-1	SPACER,HOLD-DOWN	13	
-	1	1	240644-9	PLATE, REAR SHEAR	11	
-	-	-	-	-	10	
-	1	1	2-690482-9	PLATE, FRONT SHEAR	9	
1	1	1	6-1803001-0	ANVIL, COMBINATION, END FEED	8	
-	1	1	1-2217206-3	BLADE, SLUG	7	
-	1	1	1803203-1	BLOCK, FRONT DEPRESSOR	6	
-	1	1	7-240641-1	SPACER	5	
-	1	1	4-238011-2	BLOCK, CRIMPER SPACER	4	
1	1	1	6-1633962-4	CRIMPER, INSULATION F PREMIUM	3	
-	1	1	455888-8	SPACER, CRIMPER	2	
1	1	1	1-456408-9	CRIMPER, WIRE PREMIUM	1	
-	77	22	21	PART NO	DESCRIPTION	ITEM NO

DIMENSIONS:		TOLERANCES UNLESS OTHERWISE SPECIFIED:		OWN	15SEPT2014	TE Connectivity Harrisburg, PA 17105-3608
mm		0 PLC ±		CHK	16SEPT2014	
		1 PLC ±		APVD	16SEPT2014	
		2 PLC ±		NAME		
		3 PLC ±		PRODUCT SPEC		
		4 PLC ±		APPLICATION SPEC		
		ANGLES FINISH		SIZE		
				CAGE CODE		
				DRAWING NO		
				RESTRICTED TO		
				WEIGHT		
				SCALE		
				SHEET		
				OF		
				REV		
				B		

LOC	DIST	REVISIONS			
A	66	REV	DATE	OWN	APVD
-	SEE SHEET 1	-	-	-	-

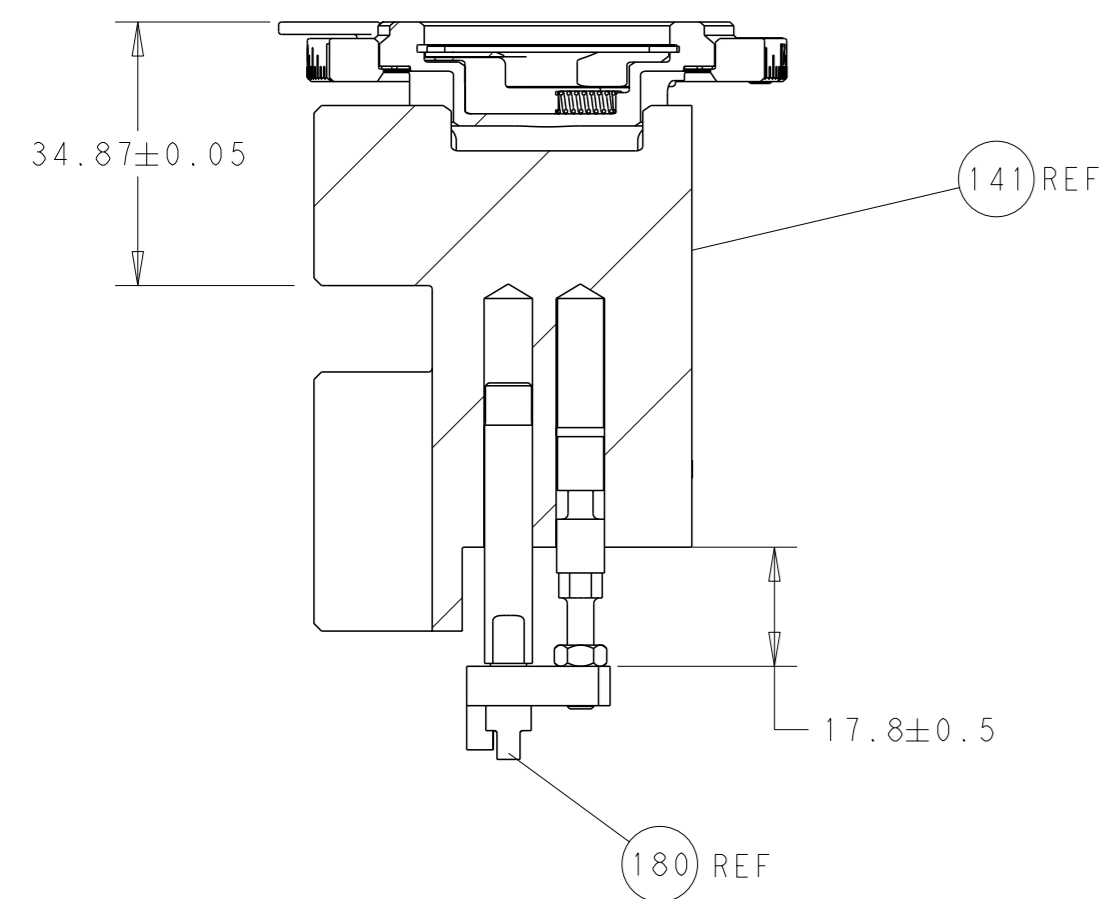

RAM AND HOLDDOWN SET-UP

FEED TYPE
MECHANICAL

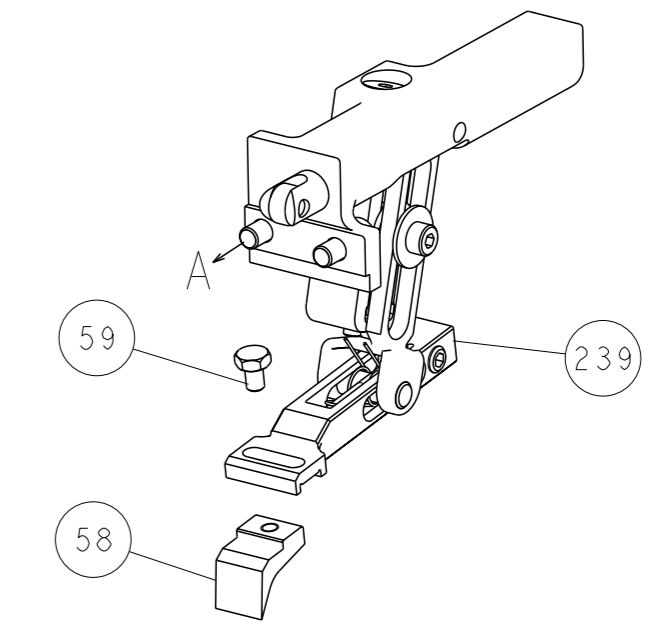

PNEUMATIC

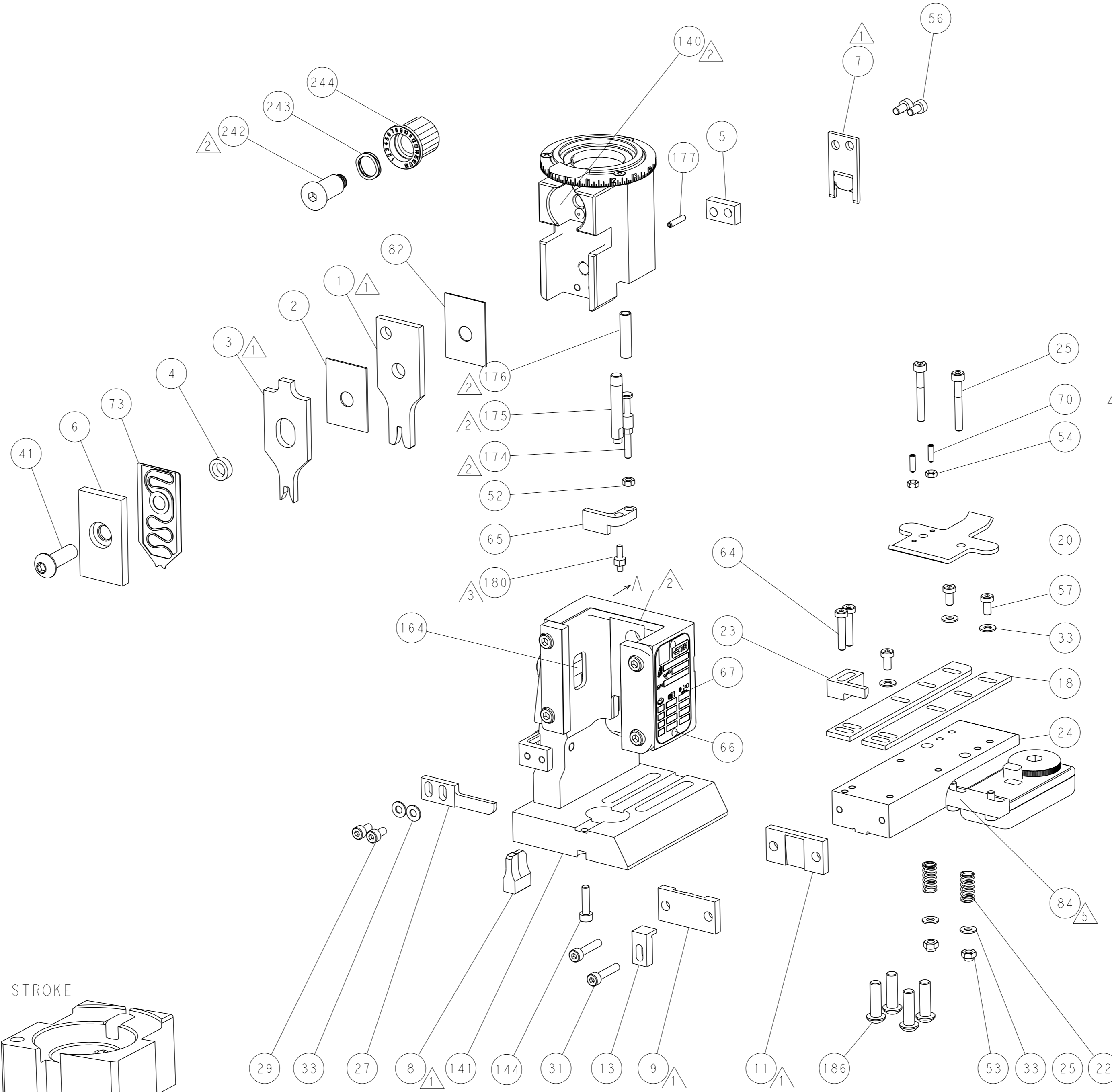
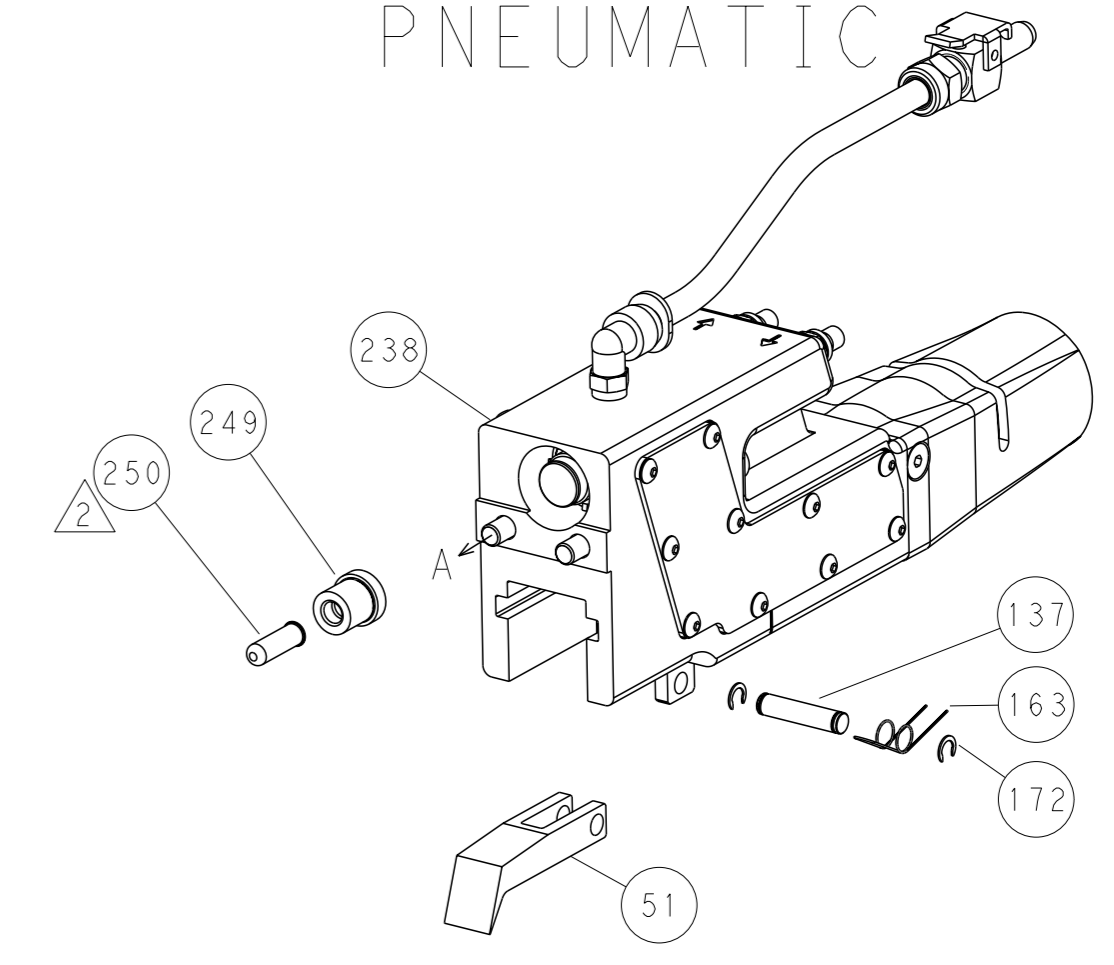

CAM POSITIONS

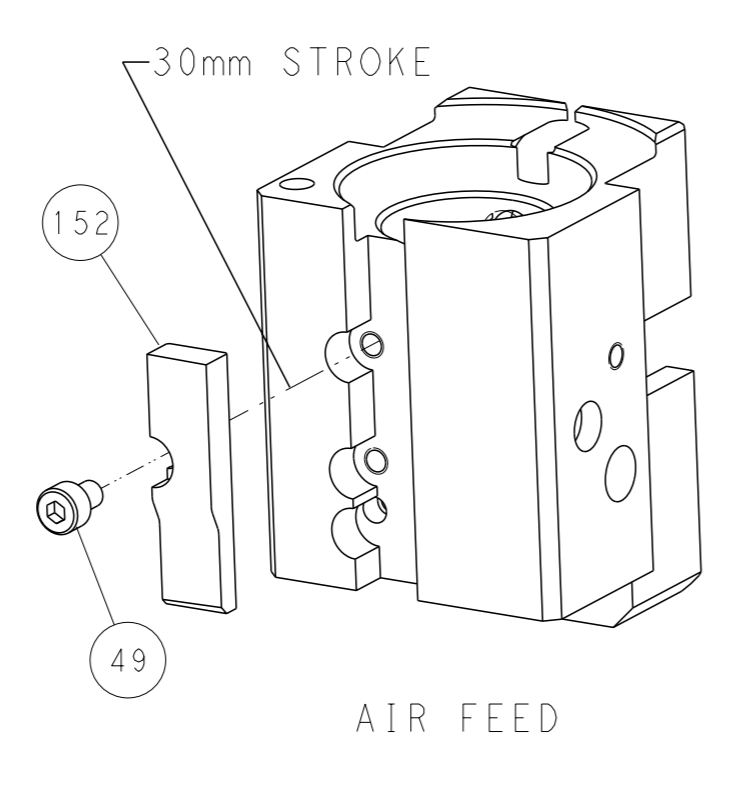
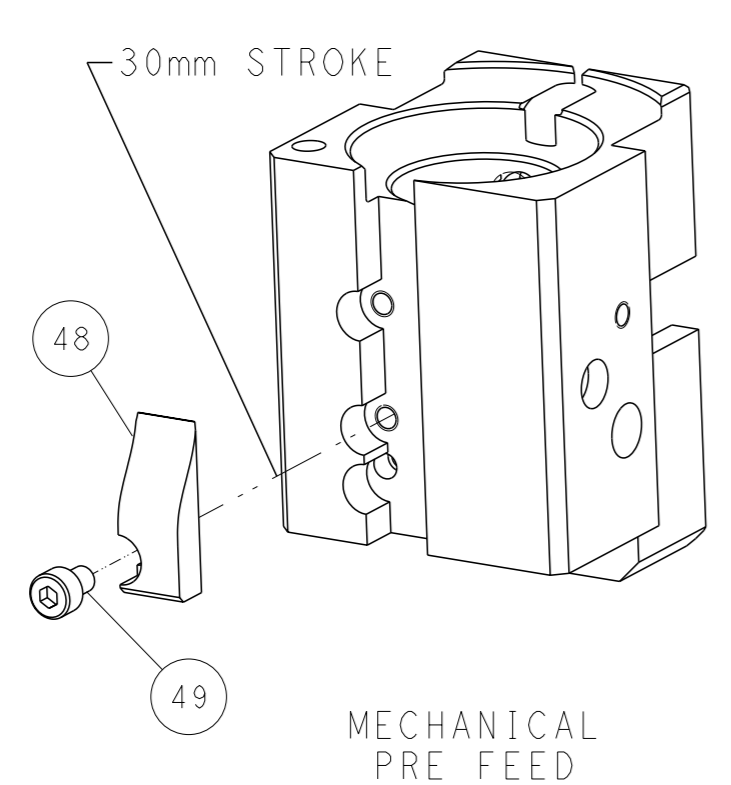
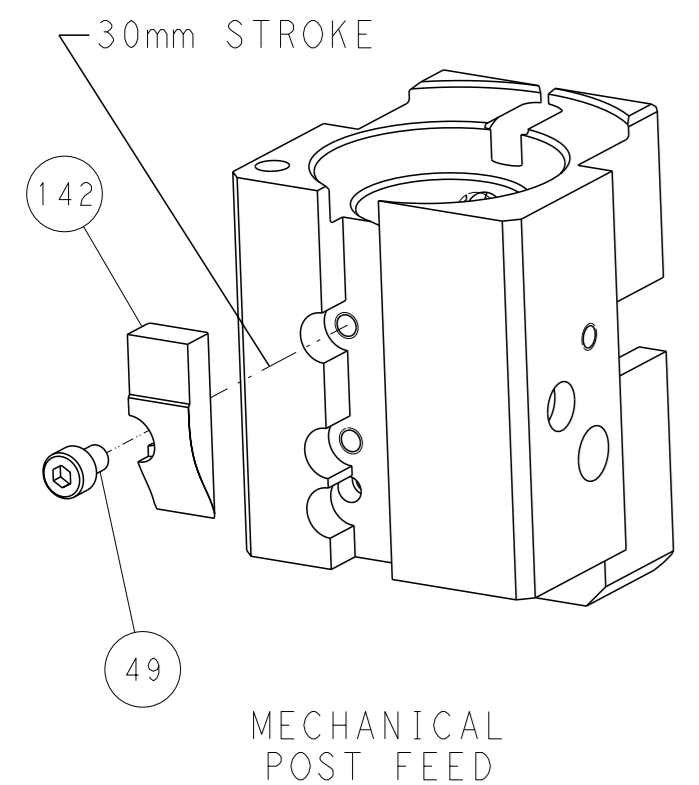

PACIFIC VERSION
 Shown on sheets 3 of 4 & 4 of 4
 (Atlantic version shown on sheets 1 of 4 & 2 of 4)

DIMENSIONS: mm 		TOLERANCES UNLESS OTHERWISE SPECIFIED: 0 PLC ± 1 PLC ± 2 PLC ± 3 PLC ± 4 PLC ± ANGLES FINISH ±		OWN: HOFFNER 15SEPT2014 CHK: T. ELBIN 16SEPT2014 APVD: T. ELBIN 16SEPT2014 PRODUCT SPEC APPLICATION SPEC WEIGHT Customer Accessible Production Drawing		NAME: Ocean End Feed Applicator SIZE: A1 CAGE CODE: 00779 DRAWING NO: C=2150488 SCALE: 1:1 SHEET: 4 of 4 REV: B		RESTRICTED TO	
-----------------------	--	--	--	--	--	---	--	---------------	--