

THIS DRAWING IS UNPUBLISHED. RELEASED FOR PUBLICATION
 © COPYRIGHT - By - ALL RIGHTS RESERVED.

REVISIONS					
P	LTR	DESCRIPTION	DATE	DWN	APVD
M		REVISED PER ECO-18-007248	25MAY2018	KH	MZ

- 1 CONTACT CAVITIES IDENTIFIED BY CHARACTERS ON FRONT FACE OF CONNECTOR.
- 2 .000030 MIN GOLD FOR A LENGTH OF .100 MIN FROM MATING END, .000100 MIN TIN-LEAD FOR A LENGTH OF "A" MIN FROM OPPOSITE END, ALL OVER .000050 MIN NICKEL.
- 3 RECOMMENDED HOLE SIZE .047 DIA FOR P.C. BOARD.
- 4 .000030 MIN GOLD FOR A LENGTH OF .100 MIN FROM MATING END, .000100 MIN TIN FOR A LENGTH OF "A" MIN FROM OPPOSITE END, ALL OVER .000050 MIN NICKEL.

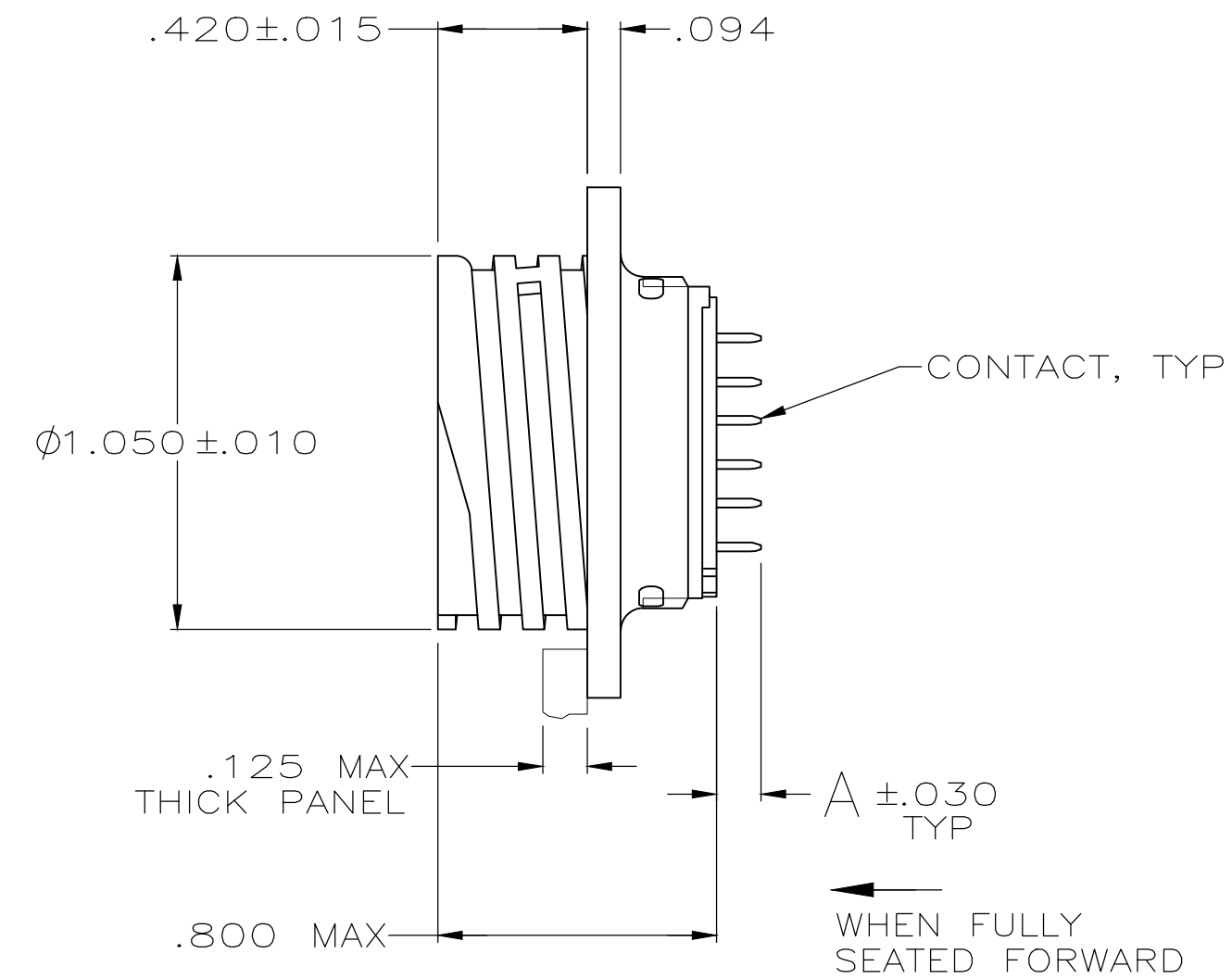
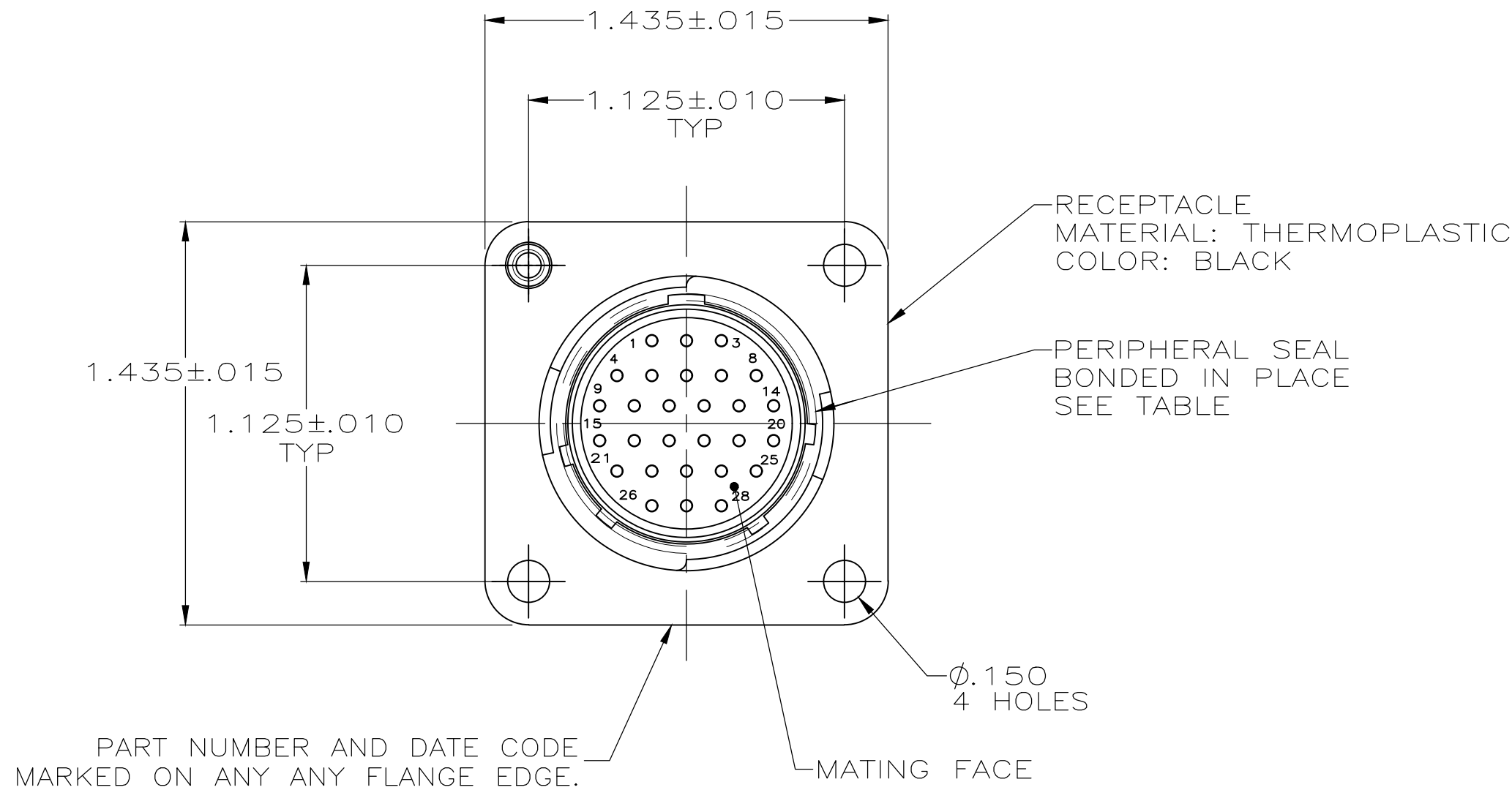

OBSOLETE	4	NO	YES	.125	1-207369-4
	4	NO	NO	.352	1-207369-3
	4	NO	NO	.125	1-207369-1
OBSOLETE	2	YES	YES	.796	-207369-5
OBSOLETE	2	NO	YES	.125	-207369-4
OBSOLETE	2	NO	NO	.352	-207369-3
OBSOLETE	2	NO	NO	-	-207369-2
	2	NO	NO	.125	207369-1
		CONTACT FINISH	PERIPHERAL SEAL	THREADED INSERT	DIM A
					PART NUMBER

THIS DRAWING IS A CONTROLLED DOCUMENT.		DWN 5-22-91 J. GALLUCCI BG	STE TE Connectivity		
DIMENSIONS: INCHES		CHK 4-14-92 W.G. LENKER			
TOLERANCES UNLESS OTHERWISE SPECIFIED:		APVD 4-14-92 K. BEAVER	NAME RECEPTACLE ASSEMBLY, POSTED, STD SEX, SERIES 2, 17-28, CPC		
0 PLC ± - 1 PLC ± - 2 PLC ± - 3 PLC ± .005 4 PLC ± - ANGLES ± -		PRODUCT SPEC 108-10024	SIZE A2	CAGE CODE 00779	DRAWING NO C-207369
MATERIAL SEE CALLOUT		FINISH -	WEIGHT -	SCALE 2:1	SHEET 1 OF 1
CUSTOMER DRAWING			RESTRICTED TO -	REV M	