

THIS DRAWING IS UNPUBLISHED. RELEASED FOR PUBLICATION
 © COPYRIGHT BY TYCO ELECTRONICS CORPORATION. ALL RIGHTS RESERVED.

LOC	DIST	REVISIONS			
P	LTR	DESCRIPTION	DATE	DWN	APVD
CM	00	G	EC 0G3B 0215 05	20SEP05	BSV RCJ

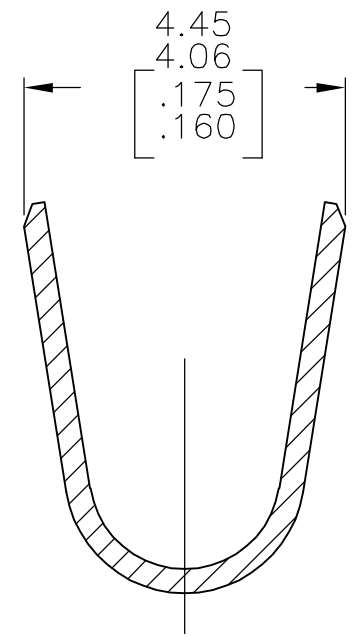
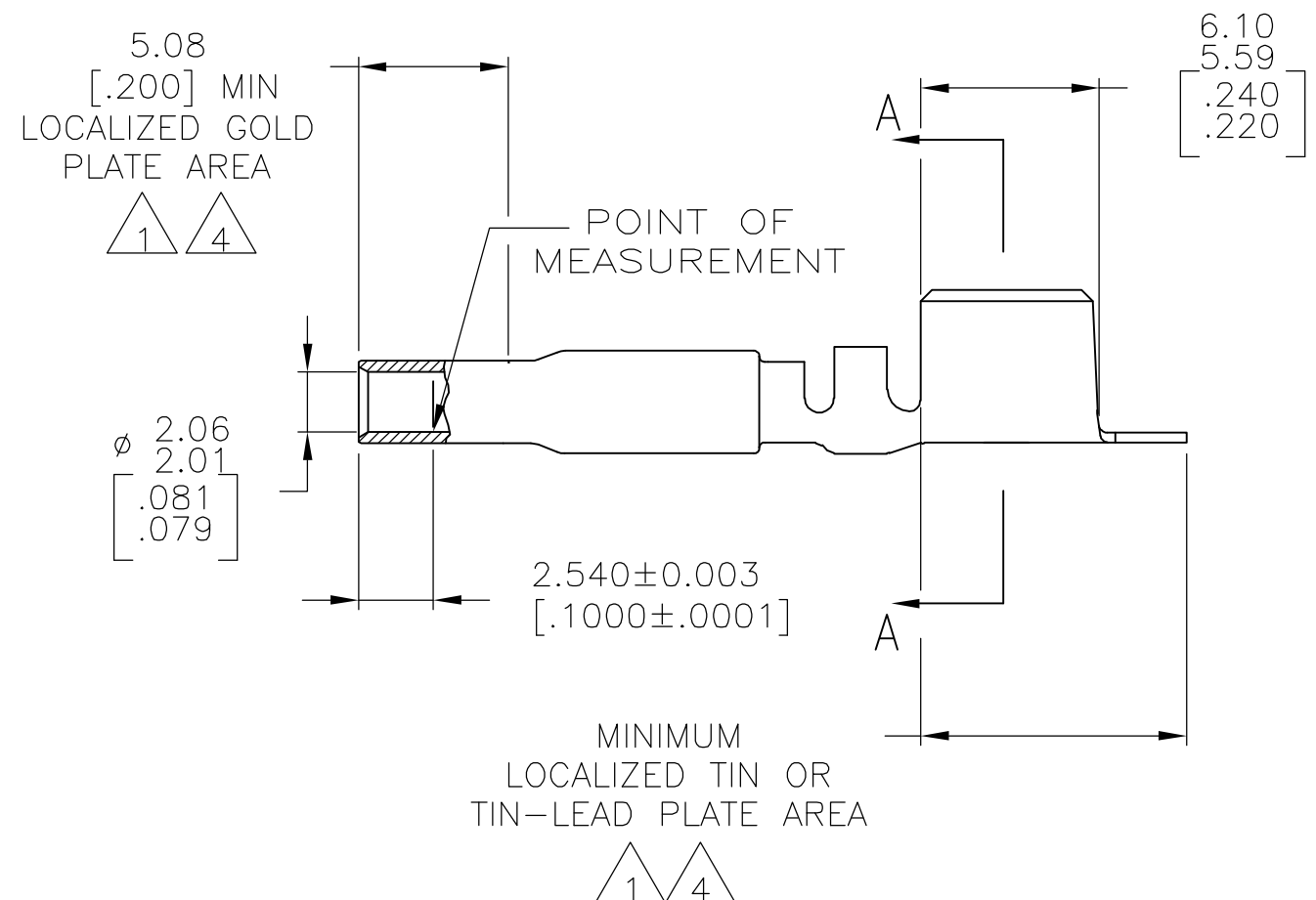
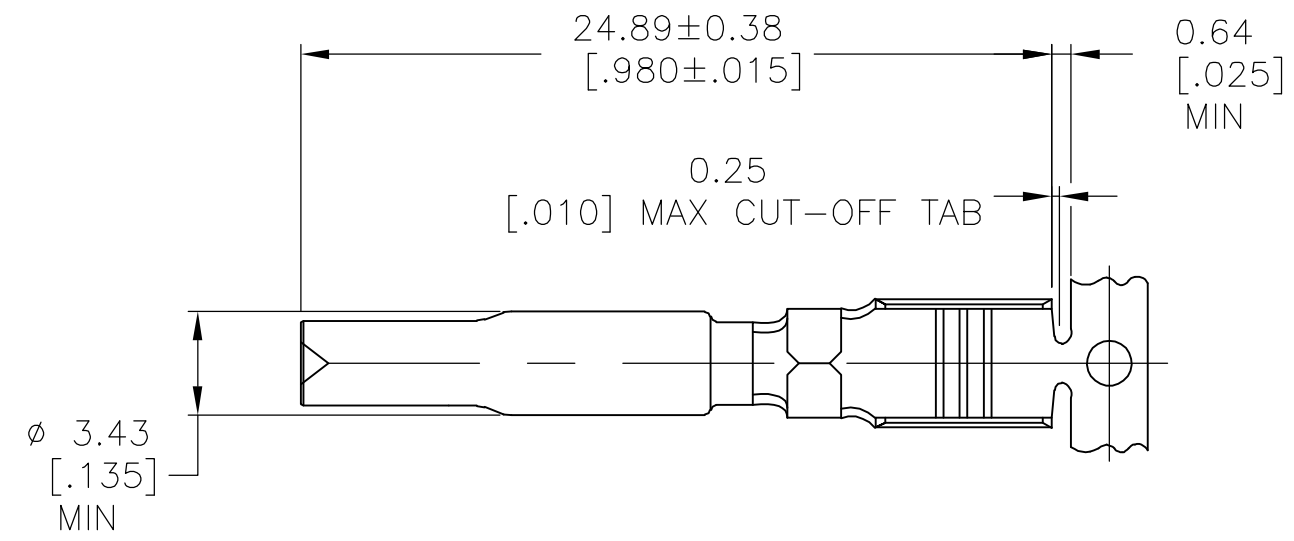

- 1. 0.00076[.000030] MIN GOLD AT POINT OF MEASUREMENT IN THE LOCALIZED GOLD PLATE AREA, 0.00127[.000050] MIN TIN-LEAD IN TIN-LEAD PLATE AREA, 0.00127[.000050] MIN NICKEL UNDERPLATE ON ENTIRE CONTACT.
- 2. WIRE RANGE: 3-6mm² [12-10 AWG].
- 3. DIMENSIONS IN BRACKETS ARE IN INCHES.
- 4. 0.00076[.000030] MIN GOLD AT POINT OF MEASUREMENT IN THE LOCALIZED GOLD PLATE AREA, 0.00127[.000050] MIN TIN IN TIN PLATE AREA, 0.00127[.000050] MIN NICKEL UNDERPLATE ON ENTIRE CONTACT.
- 5. THIS CONTACT HAS NO INSULATION BARREL.

FINISH	MATERIAL	PART NUMBER
GOLD Δ	0.30 [.012] PH BRZ	1-770004-0
GOLD Δ	0.30 [.012] PH BRZ	770004-4
PRE-TIN	0.30 [.012] PH BRZ	770004-3

THIS DRAWING IS A CONTROLLED DOCUMENT.		DWN K. WHITAKER 02APR04	Tyco Electronics Corporation Harrisburg, PA 17105-3608	
DIMENSIONS: mm [INCHES]		CHK C. JONES 02APR04	NAME -	
TOLERANCES UNLESS OTHERWISE SPECIFIED:		APVD C. JONES 02APR04	PRODUCT SPEC -	
0 PLC ± -		APPLICATION SPEC -	SIZE A2	CAGE CODE 00779
1 PLC ± -		WEIGHT -	DRAWING NO C=770004	RESTRICTED TO -
2 PLC ± -		CUSTOMER DRAWING	SCALE 4:1	SHEET 1 of 1
3 PLC ± -			REV G	
4 PLC ± -				
ANGLES ± -				
FINISH				

