

THIS DRAWING IS UNPUBLISHED. RELEASED FOR PUBLICATION . 19

© COPYRIGHT 19 BY AMP INCORPORATED, HARRISBURG, PA. ALL INTERNATIONAL RIGHTS RESERVED. AMP PRODUCTS MAY BE COVERED BY U.S. AND FOREIGN PATENTS AND/OR PATENTS PENDING.

REVISIONS				
ZONE	LTR	DESCRIPTION	DATE	APPROVED
(F)	A	RELEASED PER P.A.R.	7/26/64	SS/64

D  
C  
B  
A

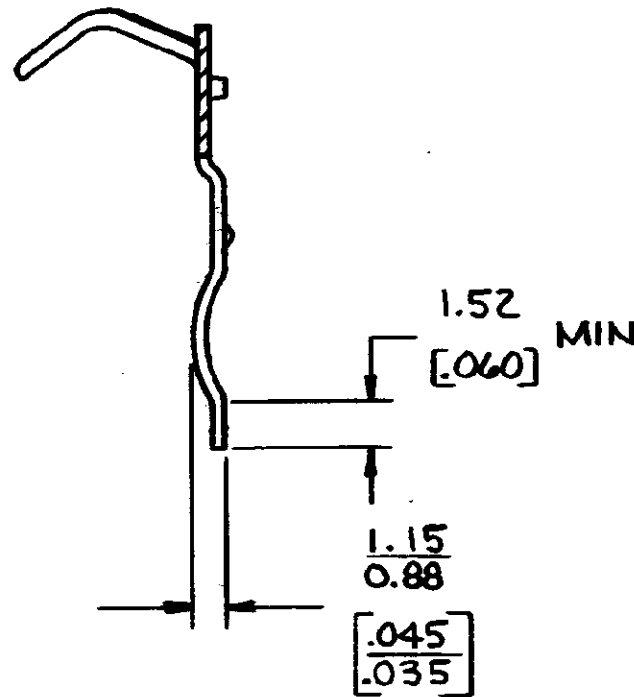
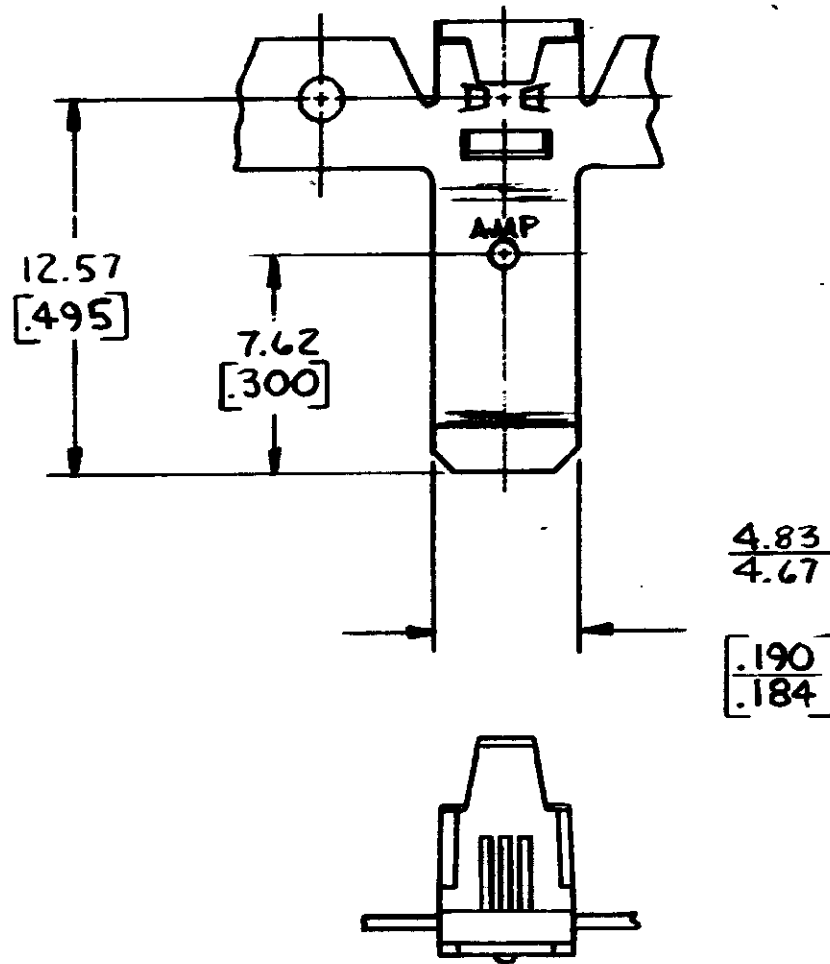

1. DIMS. IN BRACKETS ARE IN INCHES
2. CONTINUOUS STRIP ON REELS.

**METRIC**

0.5-2.0 mm <sup>2</sup> [*20-#14]	63183-1
WIRE RANGE	PART NO

UNLESS OTHERWISE SPECIFIED DIMENSIONS ARE IN <del>INCHES</del> MM. TOLERANCES ON: DECIMALS ±0.38 [015] ANGLES ±	CONTRACT NO
	DR <i>J. Schaffhausen</i> 11/18/81
	CHK <i>G. Yetter</i> 11/20/81
	APPD <i>Rohweck</i> 11-20-81
	APPD <i>D. Frantzen</i> 11/23/81
MATERIAL	0.46 [018] PHOS BRONZE
FINISH	NONE
OTHER APPD	

<b>AMP</b>   AMP INCORPORATED Harrisburg, Pa.		
NAME BRUSH CONTACT TAB-LOK (LEFT-HAND)		
SIZE <b>B</b>	FSCM NO <b>00779</b>	DRAWING NO <b>63183</b>
SCALE	SHEET	