

LOC	DIST	REVISIONS			
P	LTR	DESCRIPTION	DATE	DMN	APVD
C1	REVISED PER	ECO-11-005030	11MAR11	RK	HMR

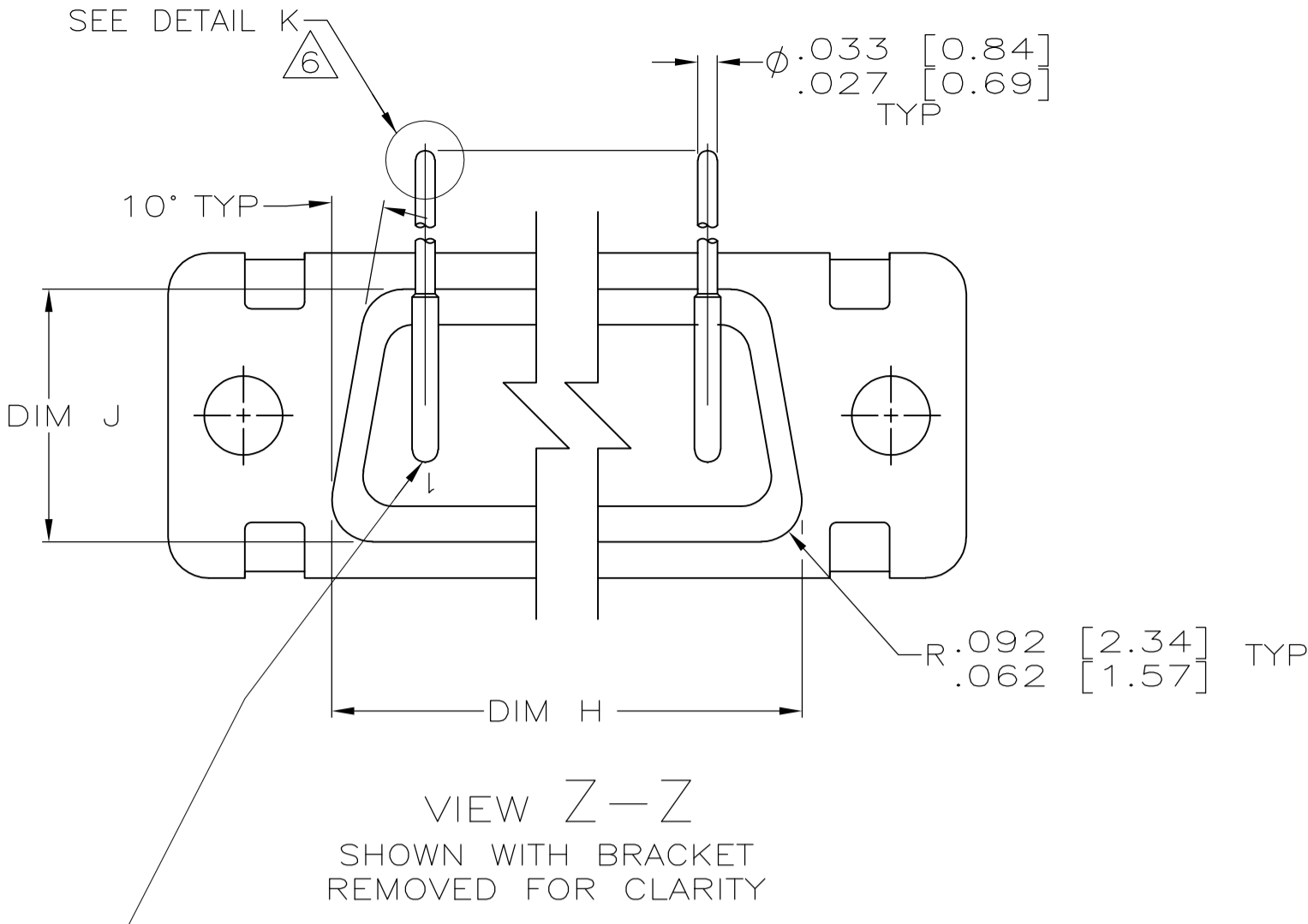
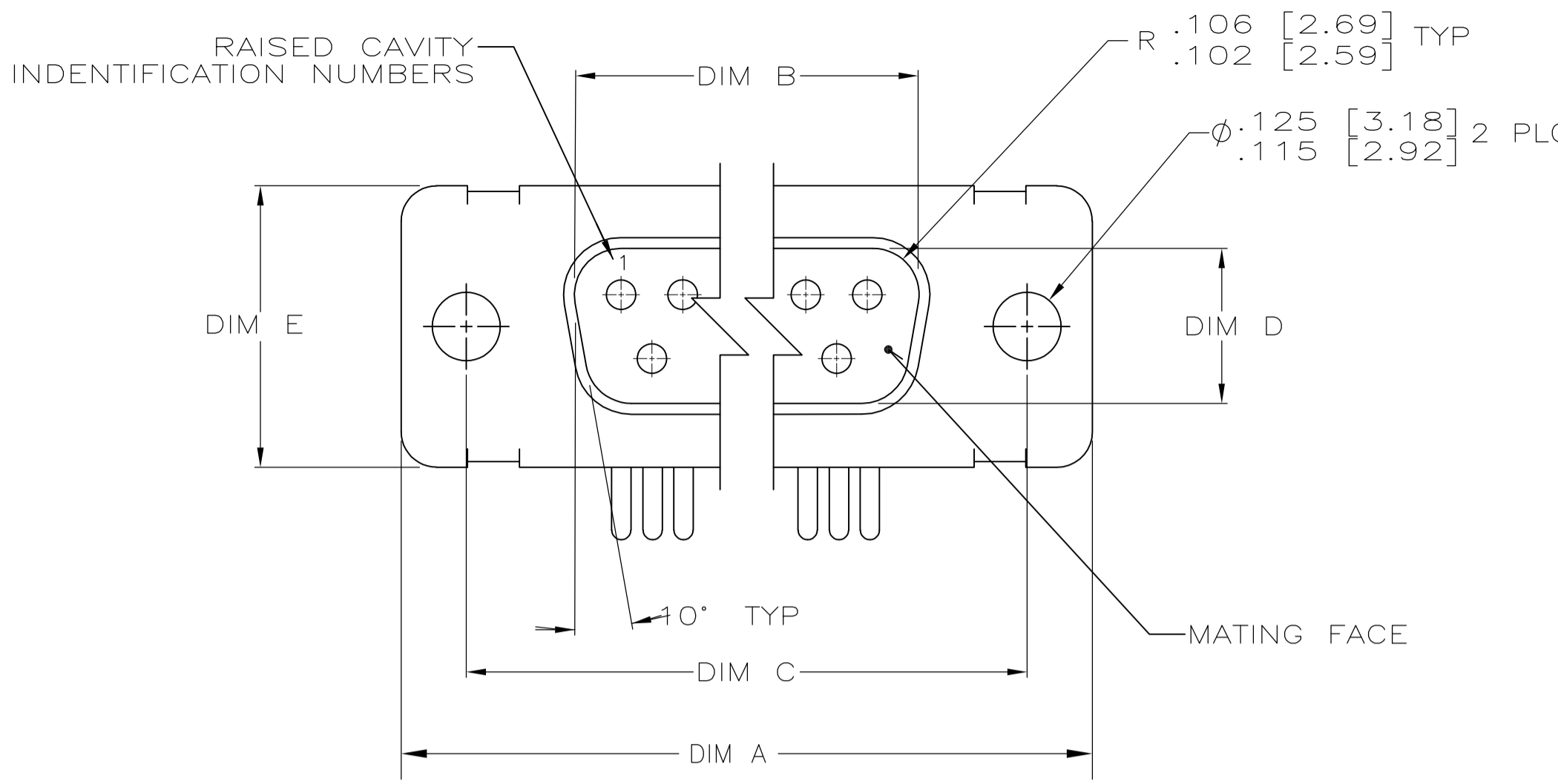

CONTACT (QTY = NO. OF POSN)  
 MATL: BRASS PER ASTM-B-16, OR BERYLLIUM COPPER PER ASTM-B-194  
 FINISH: GOLD PER MIL-G-45204, TYPE II, GRADE C, CLASS 1 IN CONTACT MATING AREA, .000010 [0.0003] MIN THK GOLD PER MIL-G-45204 OVER .000050 [0.0013] MIN THK NICKEL PER QQ-N-290 ON CONTACT BODY

- 1. SEE SHEET 2 FOR RECOMMENDED P.C. BOARD LAYOUT. TRUE POSITION TOLERANCE FOR P.C. BOARD LAYOUT IS .010 [0.25] AT MAX MATERIAL CONDITION. SUGGESTED BOARD THICKNESS IS .062 [1.57]
- 2. THE CONNECTORS DESCRIBED IN THIS DOCUMENT MEET THE REQUIREMENTS OF MIL-C-24308 AND MATE WITH ANY RECEPTACLE CONNECTOR WITH SAME INSERT ARRANGEMENT.
- 3. MARKED WITH .047 [1.19]-.062 [1.57] HIGH CHARACTERS. FAR SIDE REFERS TO THE WIDE SIDE OF THE KEYSTONE. NEAR SIDE REFERS TO THE NARROW SIDE OF THE KEYSTONE. IF THE REAR SHELL IS TOO SMALL FOR THE ENTIRE MILITARY PART NUMBER, MARKING SHALL BE LOCATED AS FOLLOWS:
  - A. "M24308" ON FRONT SHELL, FAR SIDE.
  - B. SLASH SHEET AND DASH NUMBER ON REAR SHELL, FAR SIDE.
  - C. "AMP" AND DATE CODE ON FRONT SHELL, NEAR SIDE.
  - D. PART NUMBER ON REAR SHELL, NEAR SIDE.

IF THE FRONT SHELL IS TOO SMALL FOR "AMP", PART NUMBER AND DATE CODE, MARKING SHALL BE SPLIT AS FOLLOWS:

- A. PART NUMBER ON REAR SHELL, NEAR SIDE.
- B. "AMP" AND DATE CODE ON FRONT SHELL, NEAR SIDE.
- C. MILITARY PART NUMBER ON REAR SHELL, FAR SIDE.

- 4. REQUIREMENT FOR FULL PIN DIAMETER EXTENSION: .159 [4.04] MIN, SHELL SIZES 1 AND 2. .150 [3.81] MIN, SHELL SIZES 3 AND 4.
- 5. THIS DRAWING SHALL BE INTERPRETED IN ACCORDANCE WITH APPLICABLE STANDARDS LISTED IN MIL-STD-100.
- 6. SOLDER DIPPED PER MIL-STD-2000 COMPOSITION Sn63 CONFORMING TO QQ-S-571 IN THE ENTIRE AREA OF DIMENSION SHOWN. 1218440-6 THRU -10 ONLY.

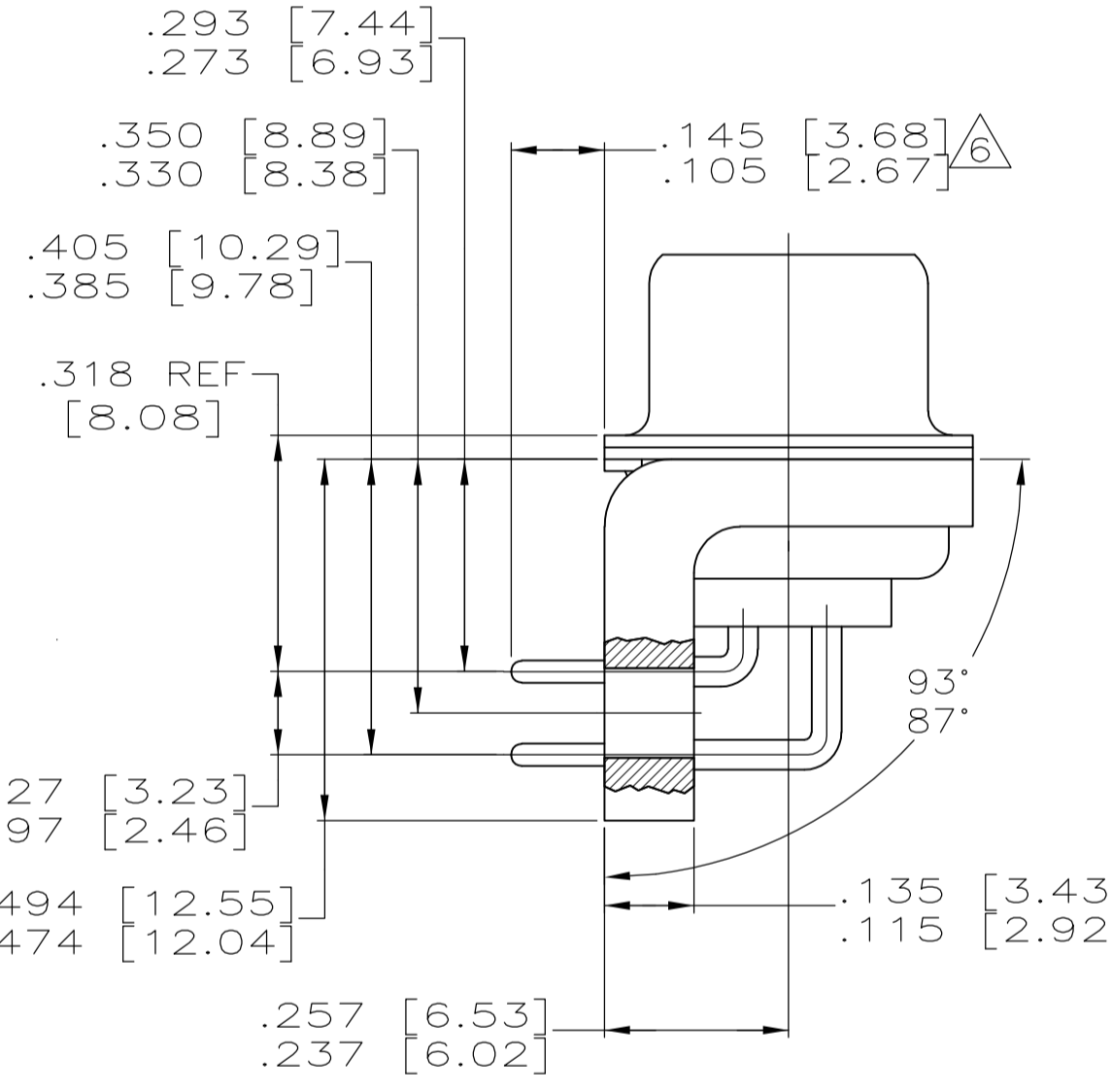
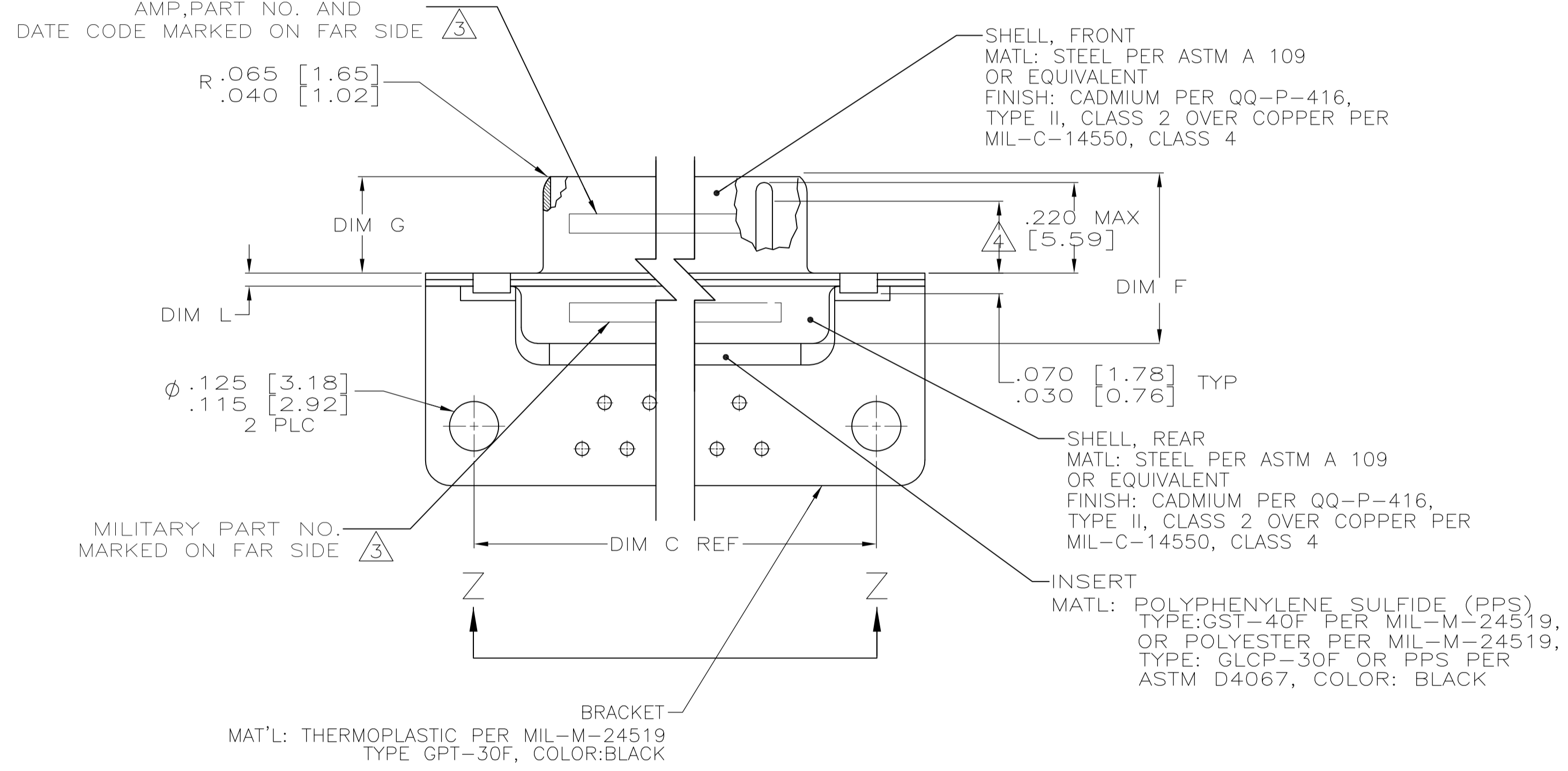

SHELL SIZES 1 THRU 4 CONTACT CONFIGURATION

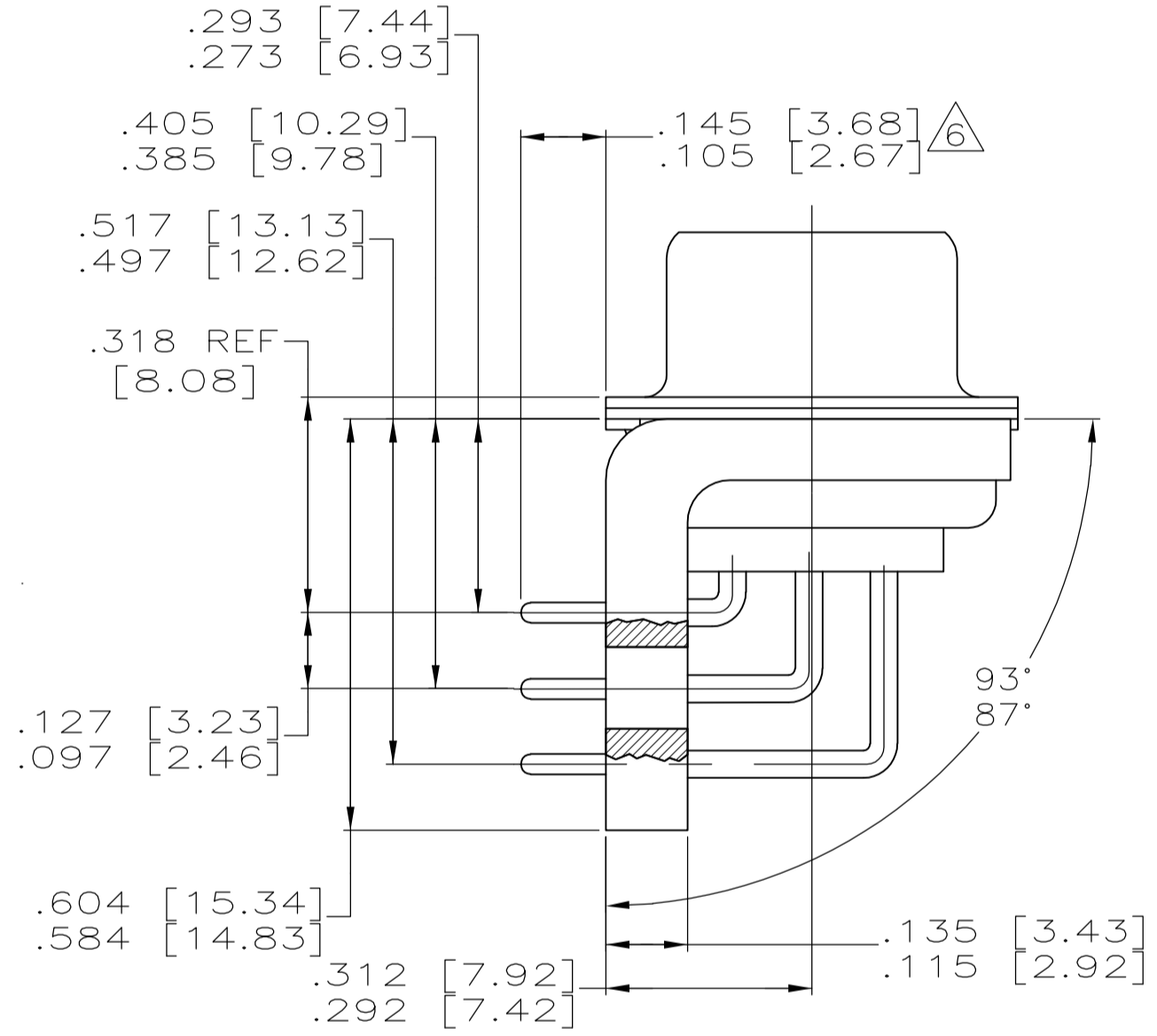

SHELL SIZE 5 CONTACT CONFIGURATION

.049	1.24	.544	13.82	2.188	55.58	.236	5.99	.436	11.07	.620	15.75	.446	11.33	2.411	61.24	2.084	52.55	2.650	67.31
.029	0.74	.524	13.31	2.168	55.07	.224	5.69	.416	10.57	.590	14.99	.436	11.07	2.401	60.99	2.074	52.30	2.620	66.55
.049	1.24	.432	10.97	2.282	57.96	.236	5.99	.436	11.07	.509	12.93	.334	8.48	2.505	63.63	2.187	54.97	2.744	69.70
.029	0.74	.412	10.46	2.262	57.45	.224	5.69	.416	10.57	.479	12.17	.324	8.23	2.495	63.37	2.177	54.71	2.714	68.94
.049	1.24	.432	10.97	1.635	41.53	.236	5.99	.436	11.07	.509	12.93	.334	8.48	1.857	47.17	1.539	38.51	2.103	53.42
.029	0.74	.412	10.46	1.615	41.02	.224	5.69	.416	10.57	.479	12.17	.324	8.23	1.847	46.91	1.529	38.25	2.073	52.65
.040	1.02	.432	10.97	1.093	27.76	.238	6.05	.432	10.97	.509	12.93	.334	8.48	1.317	33.45	.999	24.79	1.556	39.52
.020	0.51	.412	10.46	1.073	27.25	.229	5.82	.412	10.46	.479	12.17	.324	8.23	1.307	33.20	.989	24.54	1.526	38.76
.040	1.02	.432	10.97	.769	19.53	.238	6.05	.432	10.97	.509	12.93	.334	8.48	.989	25.12	.671	16.46	1.228	31.19
.020	0.51	.412	10.46	.749	19.02	.229	5.82	.412	10.46	.479	12.17	.324	8.23	.979	24.87	.661	16.21	1.198	30.43
.049	1.24	.544	13.82	2.188	55.58	.236	5.99	.436	11.07	.620	15.75	.446	11.33	2.411	61.24	2.084	52.55	2.650	67.31
.029	0.74	.524	13.31	2.168	55.07	.224	5.69	.416	10.57	.590	14.99	.436	11.07	2.401	60.99	2.074	52.30	2.620	66.55
.049	1.24	.432	10.97	2.282	57.96	.236	5.99	.436	11.07	.509	12.93	.334	8.48	2.505	63.63	2.187	54.97	2.744	69.70
.029	0.74	.412	10.46	2.262	57.45	.224	5.69	.416	10.57	.479	12.17	.324	8.23	2.495	63.37	2.177	54.71	2.714	68.94
.049	1.24	.432	10.97	1.635	41.53	.236	5.99	.436	11.07	.509	12.93	.334	8.48	1.857	47.17	1.539	38.51	2.103	53.42
.029	0.74	.412	10.46	1.615	41.02	.224	5.69	.416	10.57	.479	12.17	.324	8.23	1.847	46.91	1.529	38.25	2.073	52.65
.040	1.02	.432	10.97	1.093	27.76	.238	6.05	.432	10.97	.509	12.93	.334	8.48	1.317	33.45	.999	24.79	1.556	39.52
.020	0.51	.412	10.46	1.073	27.25	.229	5.82	.412	10.46	.479	12.17	.324	8.23	1.307	33.20	.989	24.54	1.526	38.76
.040	1.02	.432	10.97	.769	19.53	.238	6.05	.432	10.97	.509	12.93	.334	8.48	.989	25.12	.671	16.46	1.228	31.19
.020	0.51	.412	10.46	.749	19.02	.229	5.82	.412	10.46	.479	12.17	.324	8.23	.979	24.87	.661	16.21	1.198	30.43

DIM L	DIM J	DIM H	DIM G	DIM F	DIM E	DIM D	DIM C	DIM B	DIM A	INSERT ARRANGEMENT	NO OF POS	SHELL SIZE	MILITARY P/N ON CONNECTOR	P/N MARKED ON CONNECTOR	PART NO.										
.049	1.24	.544	13.82	2.188	55.58	.236	5.99	.436	11.07	.620	15.75	.446	11.33	2.411	61.24	2.084	52.55	2.650	67.31	MS18277-1	50	5	M24308/24-29F	1218440-5	1-1218440-0
.029	0.74	.524	13.31	2.168	55.07	.224	5.69	.416	10.57	.590	14.99	.436	11.07	2.401	60.99	2.074	52.30	2.620	66.55	MS18276-1	37	4	M24308/24-28F	1218440-4	1218440-9
.049	1.24	.432	10.97	2.282	57.96	.236	5.99	.436	11.07	.509	12.93	.334	8.48	2.505	63.63	2.187	54.97	2.744	69.70	MS18275-1	25	3	M24308/24-27F	1218440-3	1218440-8
.029	0.74	.412	10.46	2.262	57.45	.224	5.69	.416	10.57	.479	12.17	.324	8.23	2.495	63.37	2.177	54.71	2.714	68.94	MS18274-1	15	2	M24308/24-26F	1218440-2	1218440-7
.049	1.24	.432	10.97	1.635	41.53	.236	5.99	.436	11.07	.509	12.93	.334	8.48	1.857	47.17	1.539	38.51	2.103	53.42	MS18273-1	9	1	M24308/24-25F	1218440-1	1218440-6
.029	0.74	.412	10.46	1.615	41.02	.224	5.69	.416	10.57	.479	12.17	.324	8.23	1.847	46.91	1.529	38.25	2.073	52.65	MS18277-1	50	5	M24308/24-29F	1218440-5	1218440-5
.049	1.24	.432	10.97	2.282	57.96	.236	5.99	.436	11.07	.509	12.93	.334	8.48	2.505	63.63	2.187	54.97	2.744	69.70	MS18276-1	37	4	M24308/24-28F	1218440-4	1218440-4
.029	0.74	.412	10.46	2.262	57.45	.224	5.69	.416	10.57	.479	12.17	.324	8.23	2.495	63.37	2.177	54.71	2.714	68.94	MS18275-1	25	3	M24308/24-27F	1218440-3	1218440-3
.049	1.24	.432	10.97	1.635	41.53	.236	5.99	.436	11.07	.509	12.93	.334	8.48	1.857	47.17	1.539	38.51	2.103	53.42	MS18274-1	15	2	M24308/24-26F	1218440-2	1218440-2
.029	0.74	.412	10.46	1.615	41.02	.224	5.69	.416	10.57	.479	12.17	.324	8.23	1.847	46.91	1.529	38.25	2.073	52.65	MS18273-1	9	1	M24308/24-25F	1218440-1	1218440-1

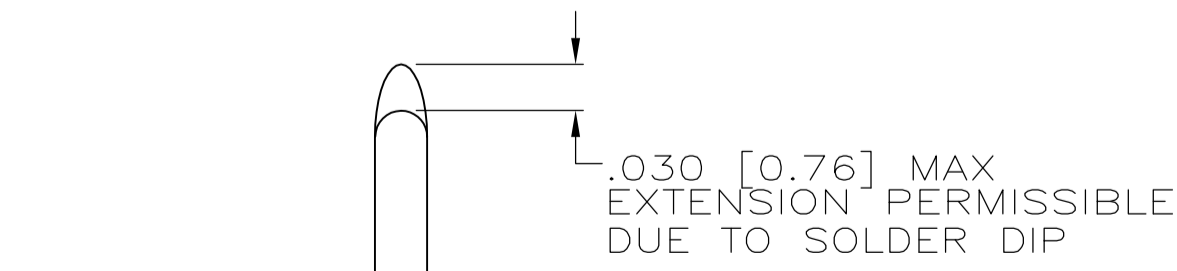

DETAIL K SCALE 8:1 FOR 1218440-6 THRU -10 ONLY

THIS DRAWING IS A CONTROLLED DOCUMENT.

DIMENSIONS: INCHES	TOLERANCES UNLESS OTHERWISE SPECIFIED:	DMN: C.C. THOMAS 11-3-99	APVD: CHAD BAKER 12-3-99
0 PLC ± .005	1 PLC ± .005	NAME: CHAD BAKER	NAME: CHAD BAKER
2 PLC ± .005	3 PLC ± .005	PRODUCT SPEC: PLUG ASSY, AMPLITE RIGHT ANGLE, SERIES 109 SIZES 1 THRU 5	SIZE: A1
4 PLC ± .005	ANGLES ± .1°	APPLICATION SPEC: SEE CALLOUTS	WEIGHT: 1.00779
MATERIAL: SEE CALLOUTS	FINISH: -	RESTRICTED TO: -	CUSTOMER DRAWING: -

SCALE: 4:1 SHEET: 1 OF 2 REV: C1

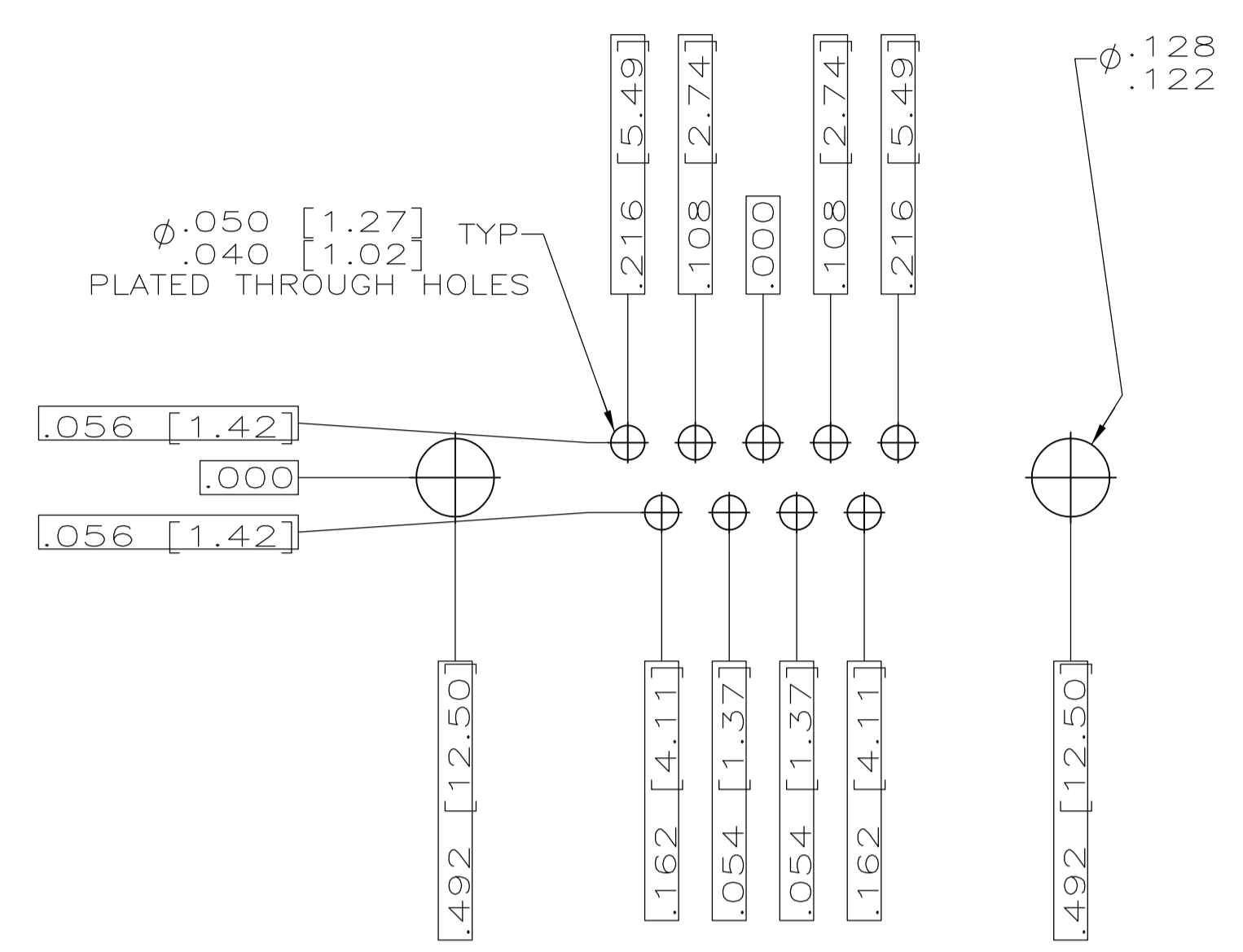

RECOMMENDED P.C. BOARD LAYOUT  
SHELL SIZE 1 (9 POSITION) ⚠

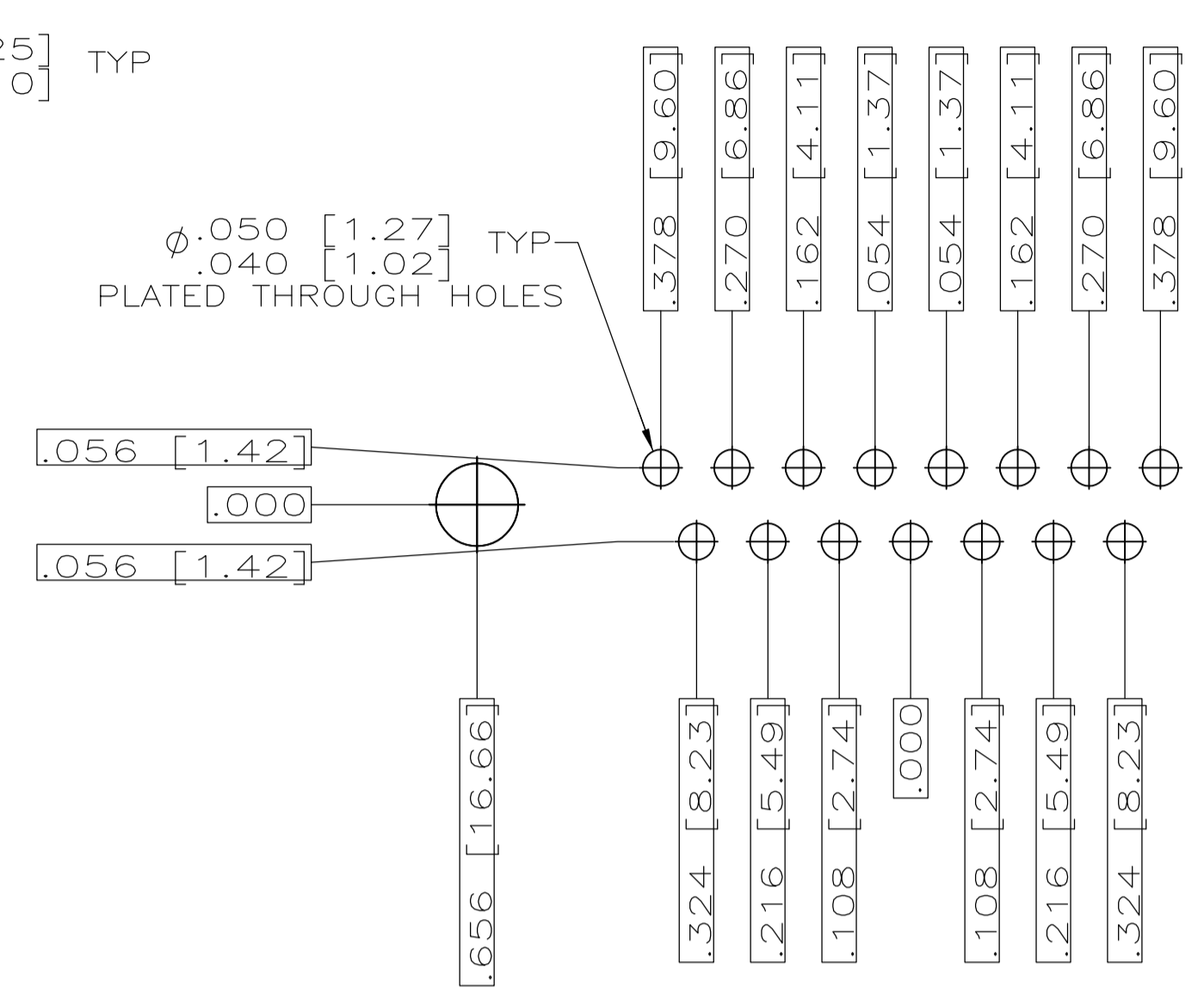

RECOMMENDED P.C. BOARD LAYOUT  
SHELL SIZE 2 (15 POSITION) ⚠

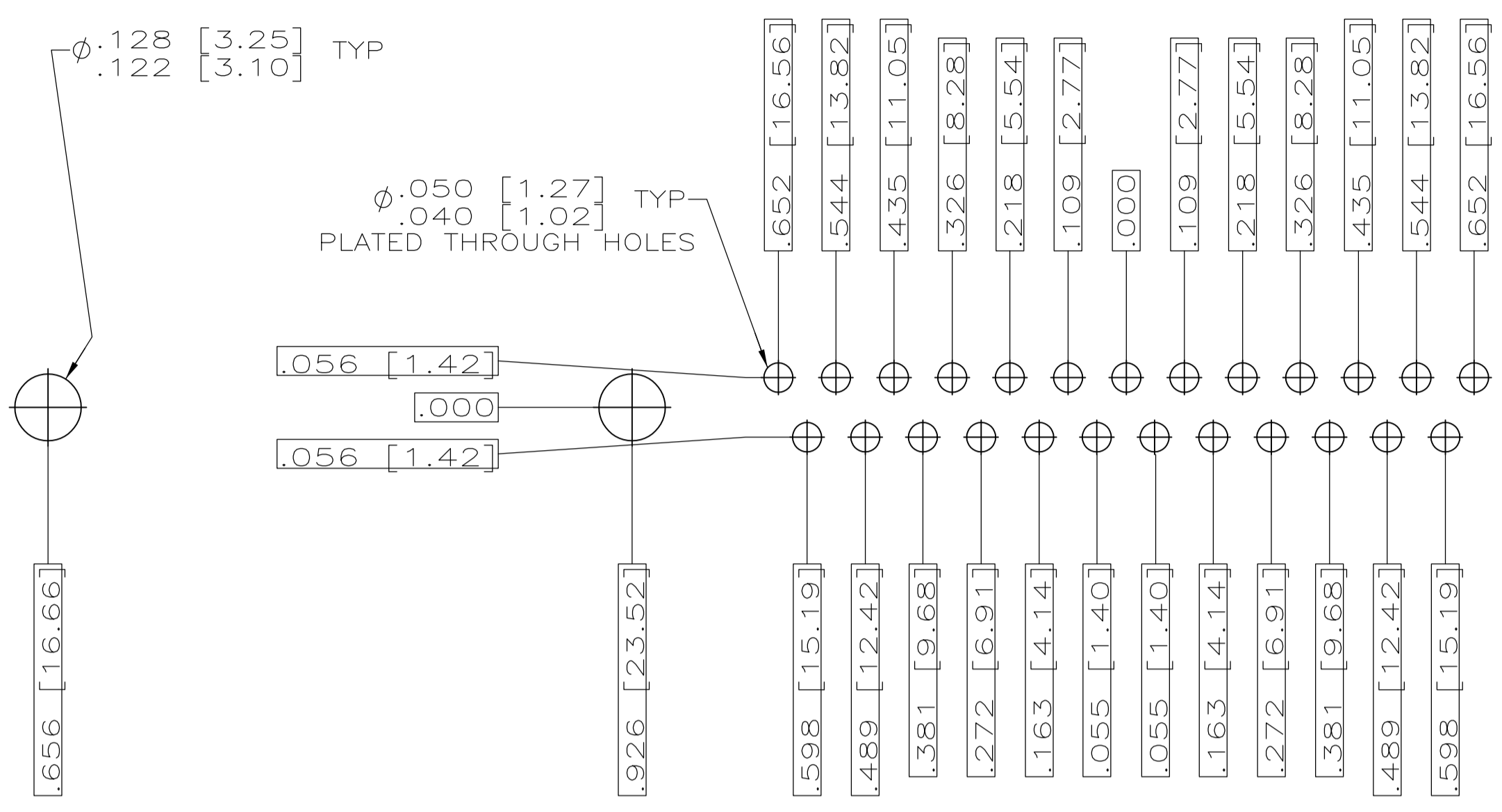

RECOMMENDED P.C. BOARD LAYOUT  
SHELL SIZE 3 (25 POSITION) ⚠

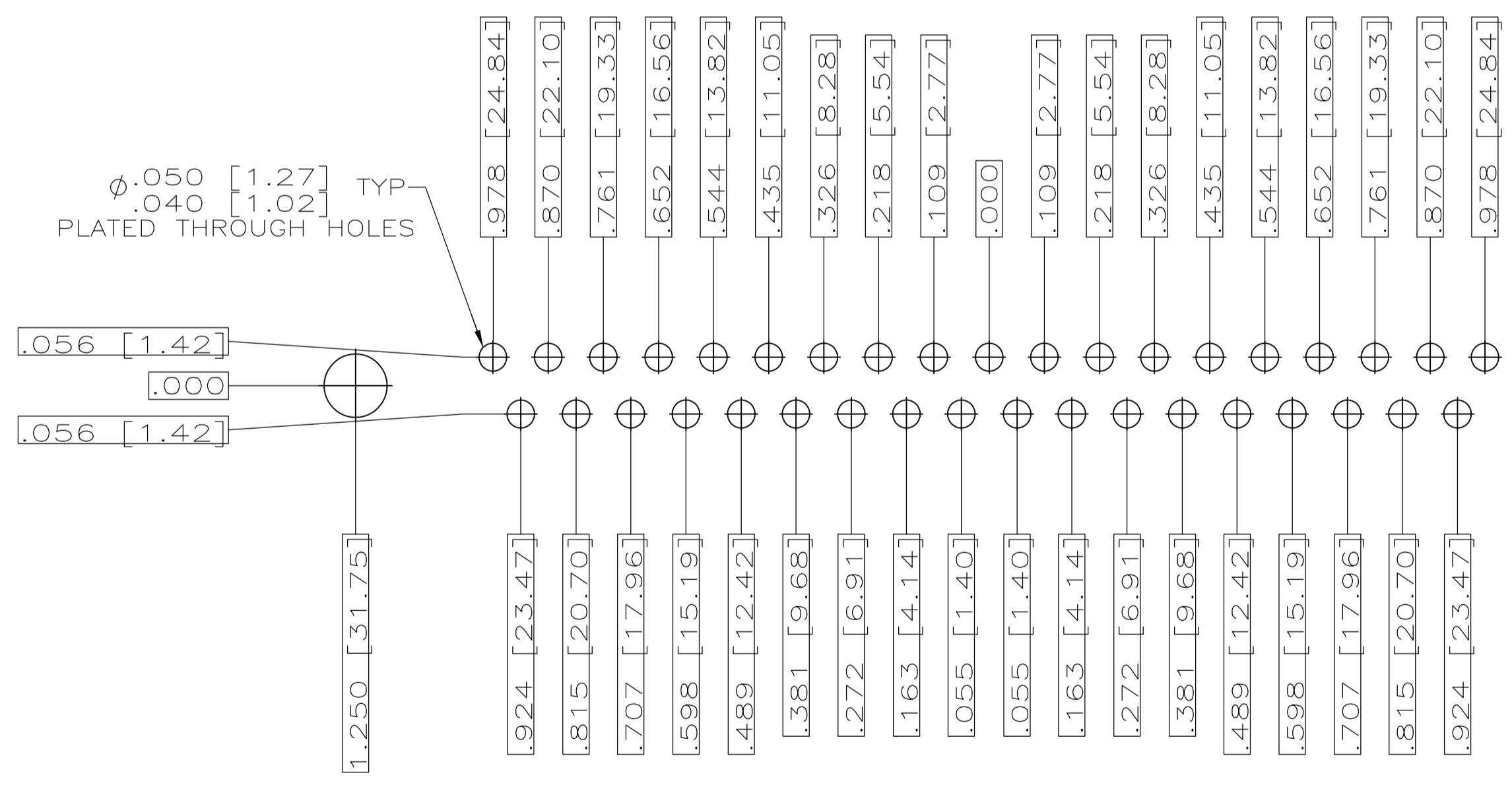

RECOMMENDED P.C. BOARD LAYOUT  
SHELL SIZE 4 (37 POSITION) ⚠

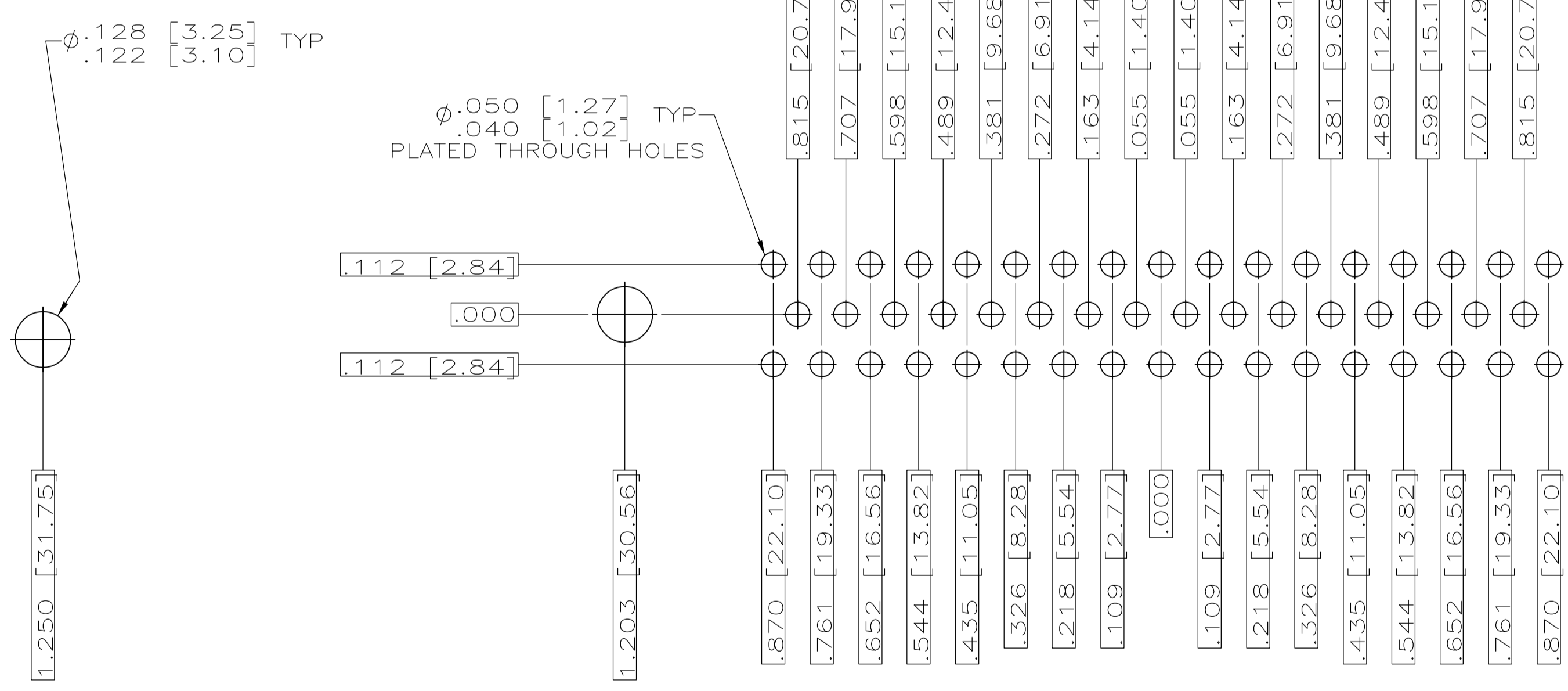

RECOMMENDED P.C. BOARD LAYOUT  
SHELL SIZE 5 (50 POSITION) ⚠

THIS DRAWING IS A CONTROLLED DOCUMENT.		DN C.C.THOMAS 11-3-99	 TE Connectivity
DIMENSIONS: INCHES		CHK CHAD BAKER 12-15-99	
TOLERANCES UNLESS OTHERWISE SPECIFIED:		APVD CHAD BAKER 12-15-99	NAME PLUG ASSY,AMPLIMITE RIGHT ANGLE,SERIES 109,SIZE 1 THRU 5
 0 PL ± .005 1 PL ± .005 2 PL ± .005 3 PL ± .005 4 PL ± .005 ANGLES ± .4°		SIZE A1	RESTRICTED TO
MATERIAL SEE CALLOUTS		WEIGHT -	SCALE 4:1
FINISH SEE CALLOUTS		DRAWING NO 00779	SHEET 2 OF 2
CUSTOMER DRAWING		REV C1	