

5-INPUT 3-OUTPUT VIDEO SWITCH FOR S2

■GENERAL DESCRIPTION

The NJM2596 is a 5-input 3-output video switch for S2.

Its switches select one from five signals received from TV, VTR, DVD, TV GAME and others.

The NJM2596 is designed for audio visual items, such as AV amplifier and others, because it includes DC interface for S2.

■PACKAGE OUTLINE

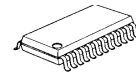

NJM2596M

■FEATURES

- Operating Voltage ± 4.0 to $\pm 6.5V$
- Operating Current $\pm 16mA$ typ. at $V_{CC}=\pm 5V$
- Internal DC Interface For S2
- Internal 6dB Amplifier
- Internal 75ohm Driver
- Bipolar Technology
- Package Outline DMP24

■BLOCK DIAGRAM

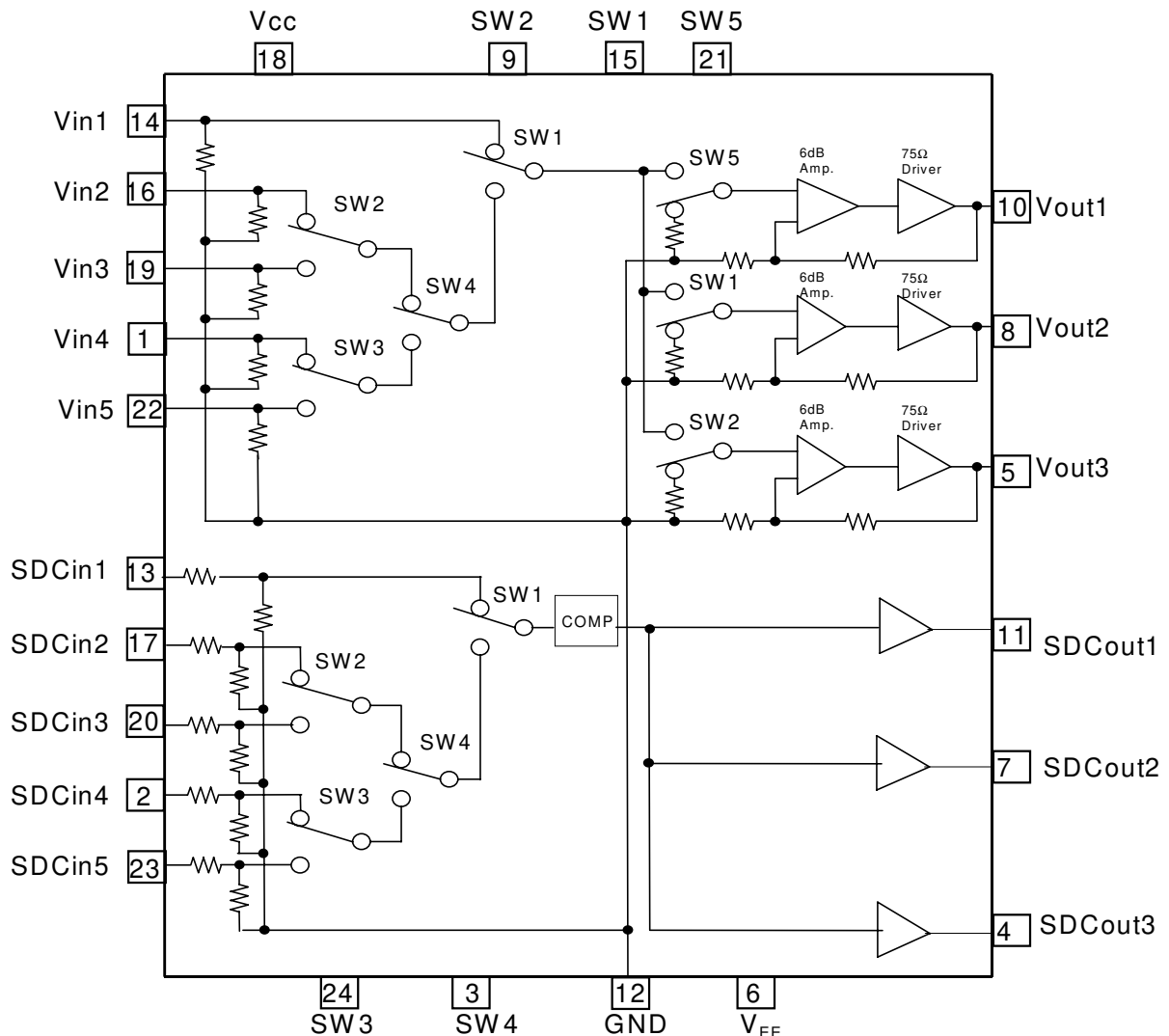

NJM2596

■ABSOLUTE MAXIMUM RATINGS

(Ta=25°C)

PARAMETER	SYMBOL	RATINGS	UNIT
Supply Voltage	Vcc	±7.0	V
Power Dissipation	P _D	500	mW
Operating Temperature Range	Topr	-40 to +85	°C
Storage Temperature Range	Tstg	-40 to +125	°C

■ELECTRICAL CHARACTERISTICS (Video System, V⁺/V⁻=±5V, R_L=150ohm, Ta=25°C)

PARAMETER	SYMBOL	TEST CONDITION	MIN.	TYP.	MAX.	UNIT
[Video System]						
Positive Operating Current	I _{cc}	No signal, at SDCout=0V	-	16.0	+29.0	mA
Negative Operating Current	I _{ee}	No signal, at SDCout=0V	-	-16.0	-29.0	mA
Voltage Gain	G _v	V _{in} =0.5V _{pp} , f=100kHz	6.0	6.3	6.8	dB
Frequency Characteristics	G _f	V _{in} =0.5V _{pp} , f=5MHz/100kHz	-1.0	0.0	+1.0	dB
Total Harmonic Distortion	THD	V _{in} =0.5V _{pp} , f=15kHz	0.0	0.1	1.0	%
Offset Output DC Voltage	V _{os}	No signal	-40	0.0	+40	mV
Between Input Crosstalk	CT	V _{in} =0.5V _{pp} , f=4.43MHz	-	-65	-	dB
Mute Crosstalk	CT _m	V _{in} =0.5V _{pp} , f=4.43MHz	-	-55	-	dB
Input Impedance	R _{in}		-	20	-	kΩ
[SDC System]						
Aspect Ratio Output DC Voltage 1	V _{Sout1}	SDC _{in} =0 to 0.5V	-0.1	0.0	0.1	V
Aspect Ratio Output DC Voltage 2	V _{Sout2}	SDC _{in} =1.3 to 2.5V	2.0	2.2	2.4	V
Aspect Ratio Output DC Voltage 3	V _{Sout3}	SDC _{in} =3.4 to V ⁺	3.5	-	-	V
Output Resistance	R _{SDC}	At Mute output	160	200	240	kΩ
[Control System]						
Switch Change High Voltage	V _{cH}		2.0	-	V ⁺	V
Switch Change Low Voltage	V _{cL}		0.0	-	0.8	V

■Control Signal - Output Signal (L=V_{CL},H=V_{CH}, X=L or H)

SW1	SW2	SW3	SW4	SW5	Vout1/SDCout1	Vout2/SDCout2	Vout3/SDCout2
L	H	X	X	H	Vin1/SDCin1	OFF	Vin1/SDCin1
	L			Vin1/SDCin1	OFF	OFF	
	H			OFF	OFF	Vin1/SDCin1	
H	L	X	L	H	Vin2/SDCin2	Vin2/SDCin2	OFF
				L	OFF	Vin2/SDCin2	OFF
H	H	X	L	H	Vin3/SDCin3	Vin3/SDCin3	Vin3/SDCin3
				L	OFF	Vin3/SDCin3	Vin3/SDCin3
H	H	L	H	H	Vin4/SDCin4	Vin4/SDCin4	Vin4/SDCin4
	H			L	OFF	Vin4/SDCin4	Vin4/SDCin4
	L			H	Vin4/SDCin4	Vin4/SDCin4	OFF
	L			L	OFF	Vin4/SDCin4	OFF
H	H	H	H	H	Vin5/SDCin5	Vin5/SDCin5	Vin5/SDCin5
	H			L	OFF	Vin5/SDCin5	Vin5/SDCin5
	L			H	Vin5/SDCin5	Vin5/SDCin5	OFF
	L			L	OFF	Vin5/SDCin5	OFF
L	L	X	X	L	OFF	OFF	OFF

* Information of [OFF]

AC System : MUTE

DC System: Connect to GND with High impedance

NJM2596

TEST CIRCUIT

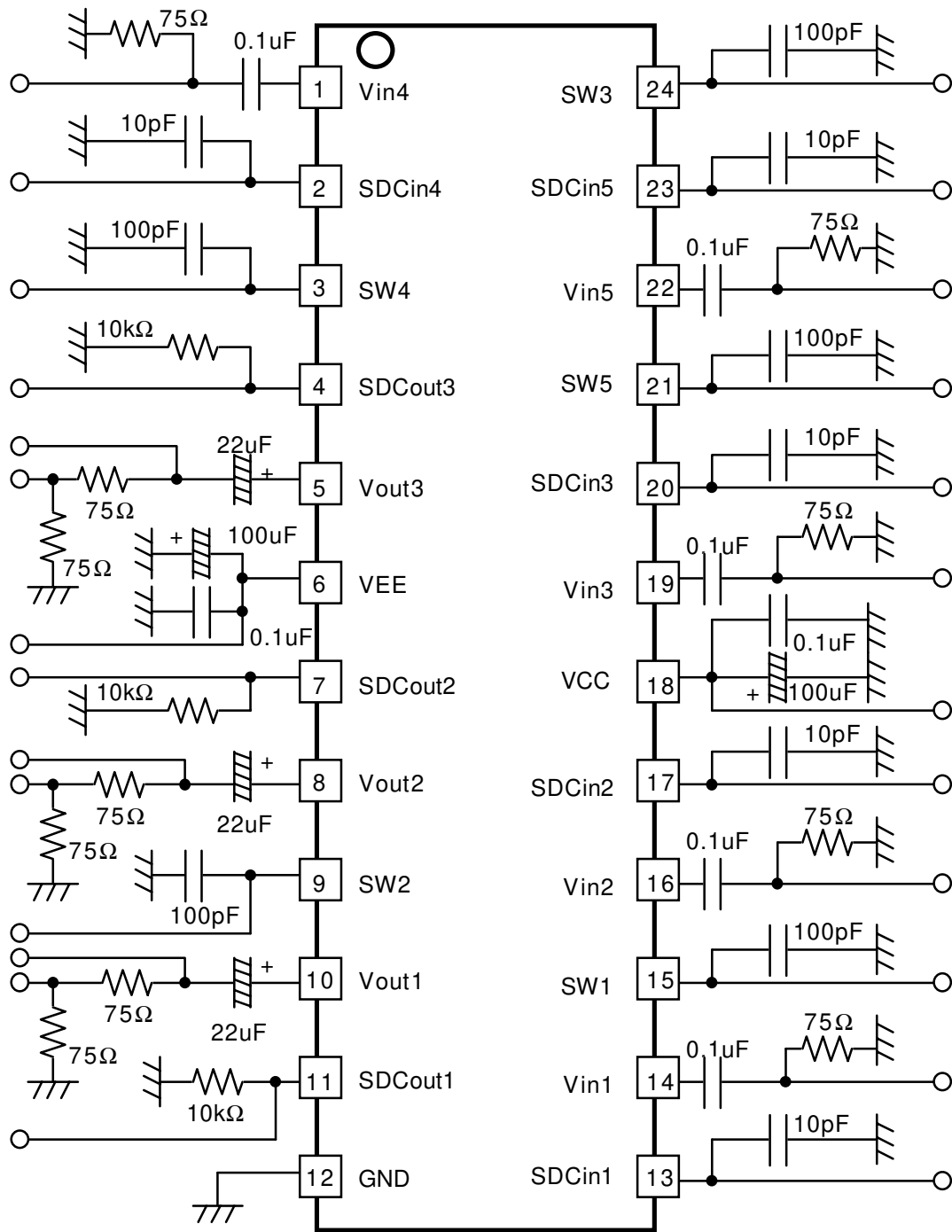

APPLICATION CIRCUIT

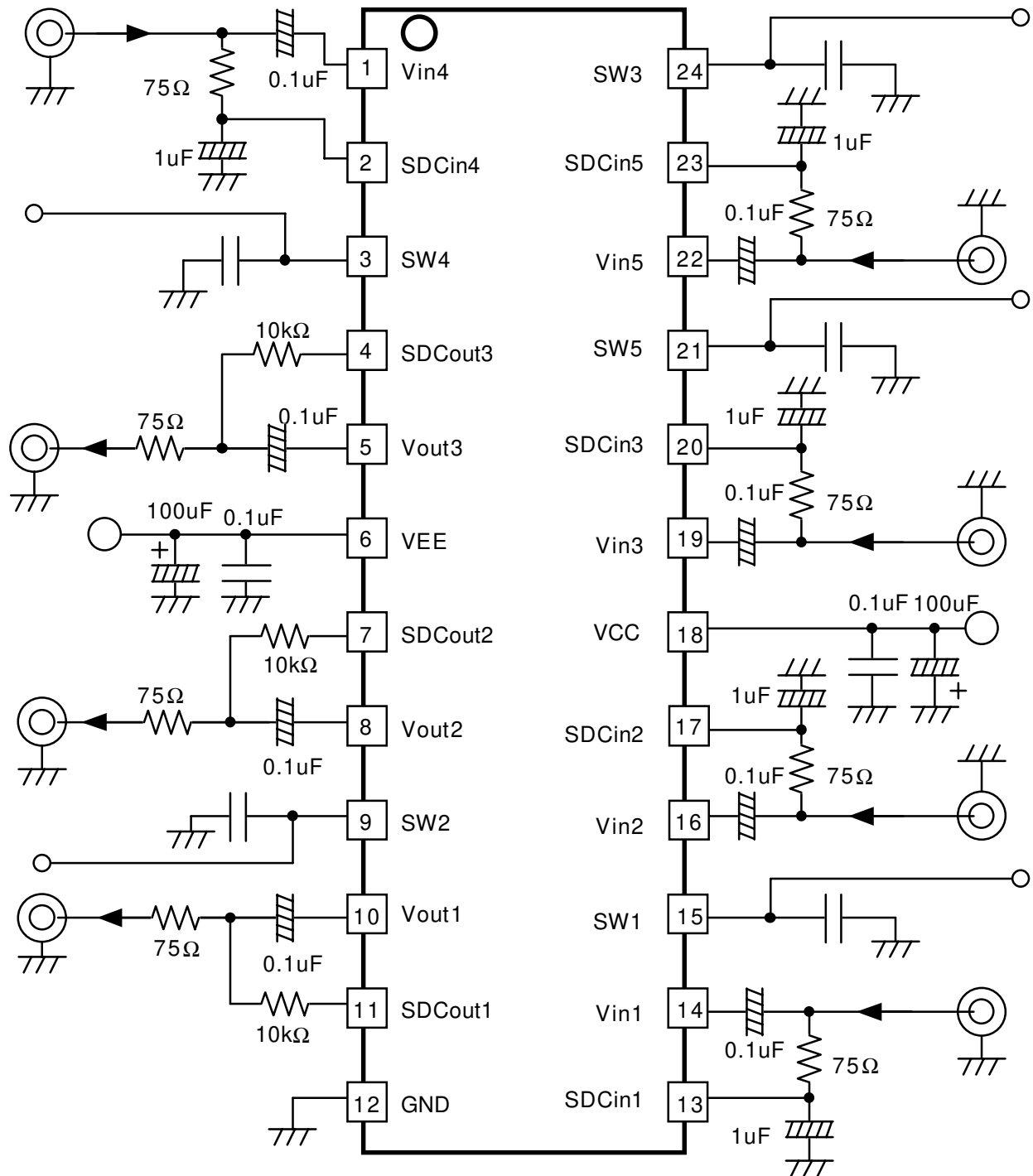

NJM2596

■EQUIVALENT CIRCUIT

PIN NO.	PIN NAME	FUNCTION	INSIDE EQUIVALENT CIRCUIT
14 16 19 1 22	Vin 1 Vin 2 Vin 3 Vin 4 Vin 5	Input video signal.	
13 17 20 2 23	SDCin1 SDCin2 SDCin3 SDCin4 SDCin5	Input signal for SDC.	
15 9 24 3 21	SW 1 SW 2 SW 3 SW 4 SW 5	Switch for select signal.	
10 8 5	Vout 1 Vout 3 Vout 2	Output video signal. Output level is 1Vpp at RL=75Ω.	
11 7 4	SDCout1 SDCout2 SDCout3	Output signal for SDC	
18	Vcc	_____	_____
12	GND	_____	_____
6	Vee	_____	_____

MEMO

[CAUTION]
The specifications on this databook are only given for information , without any guarantee as regards either mistakes or omissions. The application circuits in this databook are described only to show representative usages of the product and not intended for the guarantee or permission of any right including the industrial rights.