



# Through Hole Lamp Product Data Sheet LTL2R3KYK

Spec No.: DS-20-98-0074

Effective Date: 07/06/2000

Revision: -

**LITE-ON DCC**

**RELEASE**

BNS-OD-FC001/A4

Property of Lite-On Only

### Features

- \* High luminous intensity output.
- \* Low power consumption.
- \* High efficiency.
- \* Versatile mounting on P.C. board or panel.
- \* I.C. Compatible/low current requirements.
- \* Popular T-1 3/4 diameter.

### Package Dimensions

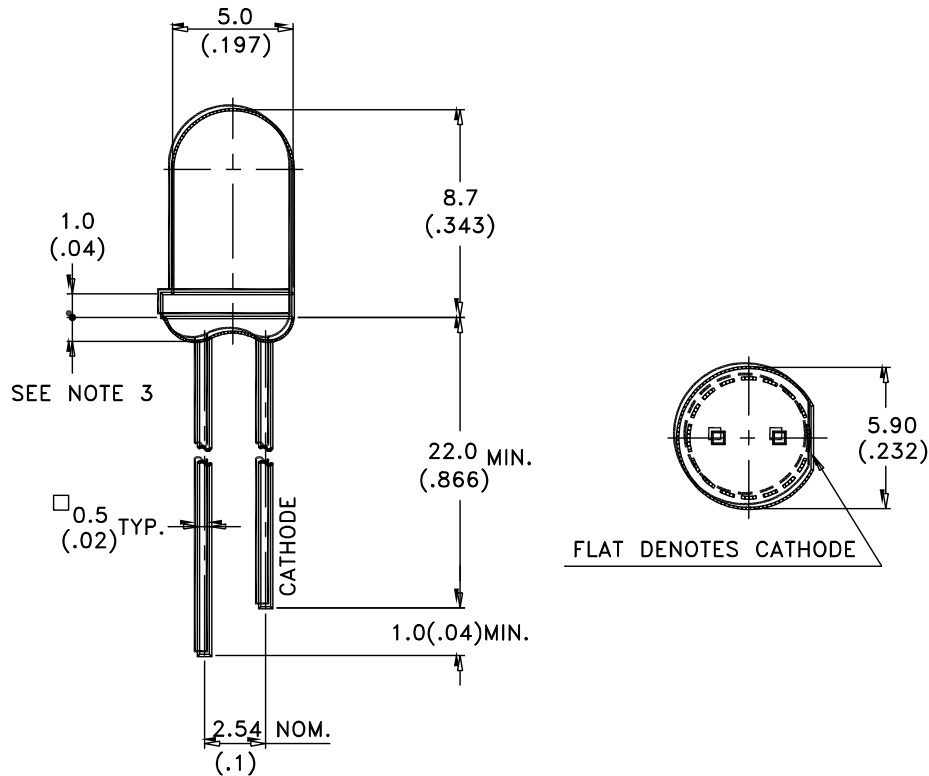

Part No.	Lens	Source Color
LTL2R3KYK	Water Clear	AlInGaP Amber Yellow

#### Notes:

1. All dimensions are in millimeters (inches).
2. Tolerance is  $\pm 0.25\text{mm} (.010\text{'})$  unless otherwise noted.
3. Protruded resin under flange is 1.0mm(.04") max.
4. Lead spacing is measured where the leads emerge from the package.
5. Specifications are subject to change without notice.



Property of Lite-On Only

**Absolute Maximum Ratings at TA=25°C**

Parameter	Maximum Rating	Unit
Power Dissipation	75	mW
Peak Forward Current (1/10 Duty Cycle, 0.1ms Pulse Width)	60	mA
Continuous Forward Current	30	mA
Derating Linear From 50°C	0.4	mA/°C
Reverse Voltage	5	V
Operating Temperature Range	-40°C to + 100°C	
Storage Temperature Range	-55°C to + 100°C	
Lead Soldering Temperature [1.6mm(.063") From Body]	260°C for 5 Seconds	



Property of Lite-On Only

Electrical / Optical Characteristics at TA=25°C

Parameter	Symbol	Min.	Typ.	Max.	Unit	Test Condition
Luminous Intensity	I <sub>v</sub>	180	700		mcd	I <sub>F</sub> = 20mA Note 1
Viewing Angle	2θ <sub>1/2</sub>		30		deg	Note 2 (Fig.5)
Peak Emission Wavelength	λ <sub>P</sub>		595		nm	Measurement @Peak (Fig.1)
Dominant Wavelength	λ <sub>d</sub>		592		nm	Note 4
Spectral Line Half-Width	Δλ		15		nm	
Forward Voltage	V <sub>F</sub>		2.05	2.4	V	I <sub>F</sub> = 20mA
Reverse Current	I <sub>R</sub>			100	μA	V <sub>R</sub> = 5V
Capacitance	C		40		pF	V <sub>F</sub> = 0 , f = 1MHz

NOTE: 1. Luminous intensity is measured with a light sensor and filter combination that approximates the CIE eye-response curve.

2. θ<sub>1/2</sub> is the off-axis angle at which the luminous intensity is half the axial luminous intensity.

3. I<sub>v</sub> classification code is marked on each packing bag.

4. The dominant wavelength, λ<sub>d</sub> is derived from the CIE chromaticity diagram and represents the single wavelength which defines the color of the device.

## Property of Lite-On Only

### Typical Electrical / Optical Characteristics Curves

(25°C Ambient Temperature Unless Otherwise Noted)

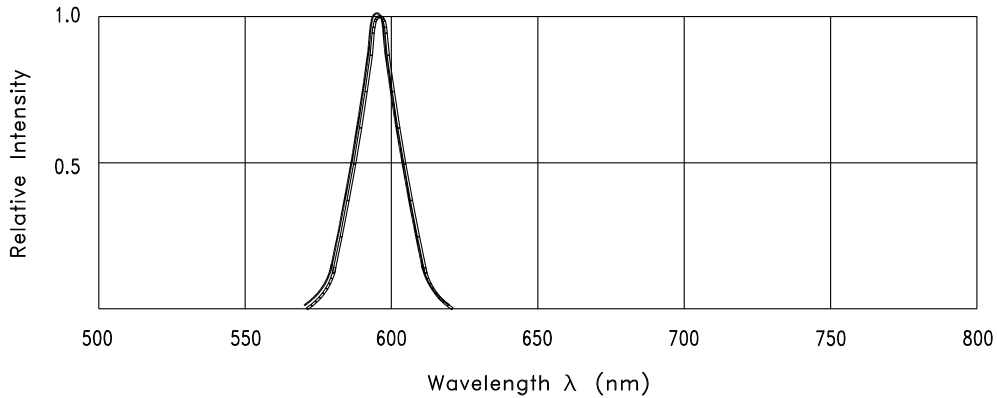

Fig.1 Relative Intensity vs. Wavelength

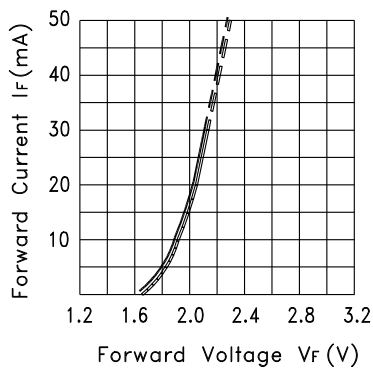

Fig.2 Forward Current vs. Forward Voltage

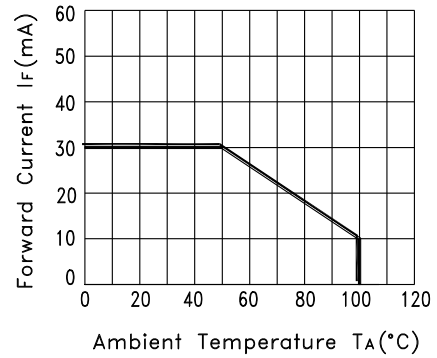

Fig.3 Forward Current Derating Curve

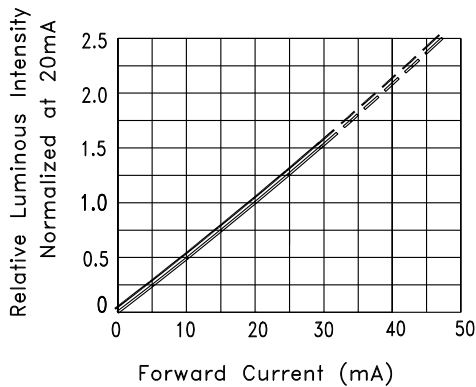

Fig.4 Relative Luminous Intensity vs. Forward Current

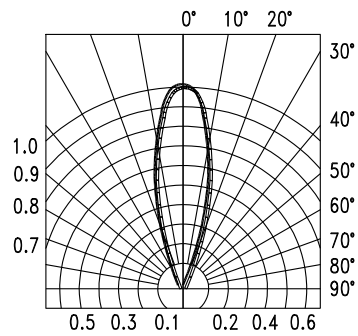

Fig.5 Spatial Distribution