

Real-Time Clock (RTC)

Features

- ACPI-compliant day-of-month alarm
- Direct clock/calendar replacement for IBM® AT-compatible computers and other applications
- 2.7–5.5V operation (bq3285LD); 4.5–5.5V operation (bq3285ED)
- 242 bytes of general nonvolatile storage
- Dedicated 32.768kHz output pin
- System wake-up capability—alarm interrupt output active in battery-backup mode
- Less than 0.55µA load under battery operation
- Selectable Intel or Motorola bus timing
- 24-pin plastic SSOP

General Description

The CMOS bq3285ED/LD is a low-power microprocessor peripheral providing a time-of-day clock and 100-year calendar with alarm features and battery operation. The architecture is based on the bq3285/7 RTC with added features: low-voltage operation, 32.768kHz output, 128 additional bytes of CMOS, and a day-of-month alarm to be compliant with the ACPI RTC specification.

A 32.768kHz output is available for sustaining power-management activities. The bq3285ED/LD 32kHz output is always on whenever V_{CC} is valid. In V_{CC} standby mode, the 32kHz is active, and the bq3285LD typically draws 100µA while the bq3285ED typically draws 300µA. Wake-up capability is provided by an alarm interrupt, which is active in battery-backup mode. In battery-backup mode, current drain is less than 550nA.

The bq3285ED/LD write-protects the clock, calendar, and storage registers during power failure. A backup battery then maintains data and operates the clock and calendar.

The bq3285ED/LD is a fully compatible real-time clock for IBM AT-compatible computers and other applications. The only external components are a 32.768kHz crystal and a backup battery.

The bq3285ED is intended for use in 5V systems. The bq3285LD is intended for use in 3V systems; the bq3285LD, however, may also operate at 5V and then go into a 3V power-down state, write-protecting as if in a 3V system.

Pin Connections

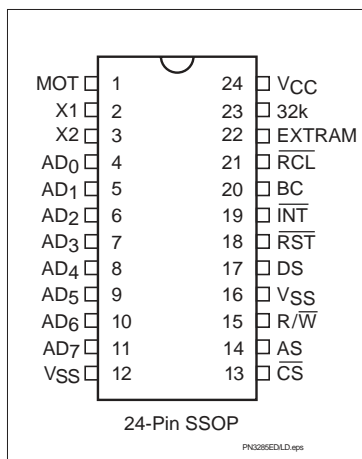

July 1997

Pin Names

AD ₀ –AD ₇	Multiplexed address/data input/output	32K	32.768kHz output
MOT	Bus type select input	EXTRAM	Extended RAM enable
\overline{CS}	Chip select input	RCL	RAM clear input
AS	Address strobe input	BC	3V backup cell input
DS	Data strobe input	X1–X2	Crystal inputs
$\overline{R/W}$	Read/write input	V _{CC}	Power supply
\overline{INT}	Interrupt request output	V _{SS}	Ground
RST	Reset input		

bq3285ED/LD

Block Diagram

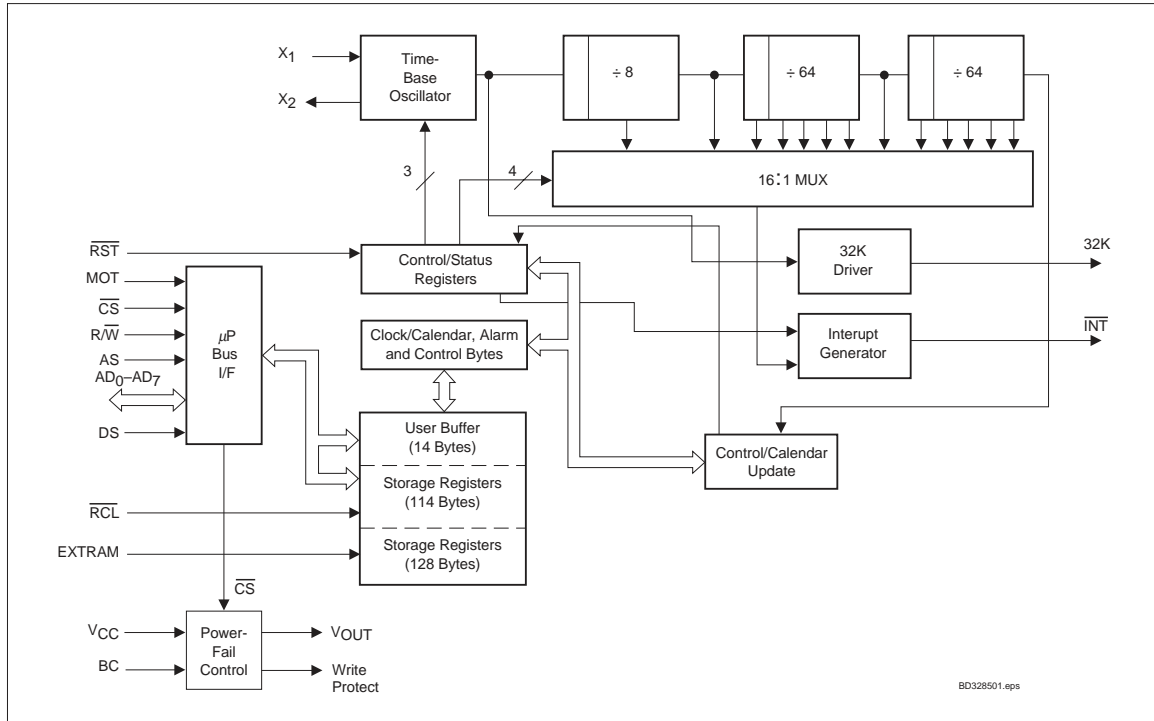

Pin Descriptions

MOT Bus type select input

MOT selects bus timing for either Motorola or Intel architecture. This pin should be tied to V_{CC} for Motorola timing or to V_{SS} for Intel timing (see Table 1). The setting should not be changed during system operation. MOT is internally pulled low by a 30K Ω resistor.

Table 1. Bus Setup

Bus Type	MOT Level	DS Equivalent	R/W Equivalent	AS Equivalent
Motorola	V _{CC}	DS, E, or φ ₂	R/W	AS
Intel	V _{SS}	R _D , MEMR, or I/OR	WR, MEMW, or I/OW	ALE

AD₀-AD₇ Multiplexed address/data input/output

The bq3285ED/LD bus cycle consists of two phases: the address phase and the data-transfer phase. The address phase precedes the data-transfer phase. During the address phase, an address placed on AD₀-AD₇ and EXTRAM is latched into the bq3285ED/LD on the falling edge of the AS signal. During the data-transfer phase of the bus cycle, the AD₀-AD₇ pins serve as a bidirectional data bus.

AS Address strobe input

AS serves to demultiplex the address/data bus. The falling edge of AS latches the address on AD₀-AD₇ and EXTRAM. This demultiplexing process is independent of the CS signal. For DIP and SOIC packages with MOT = V_{SS}, the AS input is provided a signal similar to ALE in an Intel-based system.

DS	<p>Data strobe input</p> <p>When $MOT = V_{CC}$, DS controls data transfer during a bq3285ED/LD bus cycle. During a read cycle, the bq3285ED/LD drives the bus after the rising edge on DS. During a write cycle, the falling edge on DS is used to latch write data into the chip.</p> <p>When $MOT = V_{SS}$, the DS input is provided a signal similar to \overline{RD}, \overline{MEMR}, or $\overline{I/OR}$ in an Intel-based system. The falling edge on DS is used to enable the outputs during a read cycle.</p>	\overline{RCL}	<p>RAM clear input</p> <p>A low level on the \overline{RCL} pin causes the contents of each of the 242 storage bytes to be set to FF(hex). The contents of the clock and control registers are unaffected. This pin should be used as a user-interface input (pushbutton to ground) and not connected to the output of any active component. \overline{RCL} input is only recognized when held low for at least 125ms in the presence of V_{CC}. Using RAM clear does not affect the battery load. This pin is connected internally to a 30kΩ pull-up resistor.</p>
$\overline{R/W}$	<p>Read/write input</p> <p>When $MOT = V_{CC}$, the level on $\overline{R/W}$ identifies the direction of data transfer. A high level on $\overline{R/W}$ indicates a read bus cycle, whereas a low on this pin indicates a write bus cycle.</p> <p>When $MOT = V_{SS}$, $\overline{R/W}$ is provided a signal similar to \overline{WR}, \overline{MEMW}, or $\overline{I/OW}$ in an Intel-based system. The rising edge on $\overline{R/W}$ latches data into the bq3285ED/LD.</p>	BC	<p>3V backup cell input</p> <p>BC should be connected to a 3V backup cell for RTC operation and storage register non-volatility in the absence of system power. When V_{CC} slews down past V_{BC} (3V typical), the integral control circuitry switches the power source to BC. When V_{CC} returns above V_{BC}, the power source is switched to V_{CC}.</p> <p>Upon power-up, a voltage within the V_{BC} range must be present on the BC pin for the oscillator to start up.</p>
\overline{CS}	<p>Chip select input</p> <p>\overline{CS} should be driven low and held stable during the data-transfer phase of a bus cycle accessing the bq3285ED/LD.</p>	\overline{RST}	<p>Reset input</p> <p>The bq3285ED/LD is reset when \overline{RST} is pulled low. When reset, \overline{INT} becomes high impedance, and the bq3285ED/LD is not accessible. Table 4 in the Control/Status Registers section lists the register bits that are cleared by a reset.</p> <p>Reset may be disabled by connecting \overline{RST} to V_{CC}. This allows the control bits to retain their states through power-down/power-up cycles.</p>
\overline{INT}	<p>Interrupt request output</p> <p>\overline{INT} is an open-drain output. This allows alarm \overline{INT} to be valid in battery-backup mode. To use this feature, connect \overline{INT} through a resistor to a power supply other than V_{CC}. \overline{INT} is asserted low when any event flag is set and the corresponding event enable bit is also set. \overline{INT} becomes high-impedance whenever register C is read (see the Control/Status Registers section).</p>	X1-X2	<p>Crystal inputs</p> <p>The X1-X2 inputs are provided for an external 32.768kHz quartz crystal, Daiwa DT-26 or equivalent, with 6pF load capacitance. A trimming capacitor may be necessary for extremely precise time-base generation.</p> <p>In the absence of a crystal, a 32.768kHz waveform can be fed into the X1 input.</p>
32K	<p>32.768 kHz output</p> <p>32K provides a buffered 32.768 kHz output. The frequency remains on and fixed at 32.768kHz as long as V_{CC} is valid.</p>		
EXTRAM	<p>Extended RAM enable</p> <p>Enables 128 bytes of additional nonvolatile SRAM. It is connected internally to a 30kΩ pull-down resistor. To access the RTC registers, EXTRAM must be low.</p>		

bq3285ED/LD

Functional Description

Address Map

The bq3285ED/LD provides 14 bytes of clock and control/status registers and 242 bytes of general nonvolatile storage. Figure 1 illustrates the address map for the bq3285ED/LD.

Update Period

The update period for the bq3285ED/LD is one second. The bq3285ED/LD updates the contents of the clock and calendar locations during the update cycle at the end of

each update period (see Figure 2). The alarm flag bit may also be set during the update cycle.

The bq3285ED/LD copies the local register updates into the user buffer accessed by the host processor. When a 1 is written to the update transfer inhibit bit (UTI) in register B, the user copy of the clock and calendar bytes remains unchanged, while the local copy of the same bytes continues to be updated every second.

The update-in-progress bit (UIP) in register A is set t_{BUC} time before the beginning of an update cycle (see Figure 2). This bit is cleared and the update-complete flag (UF) is set at the end of the update cycle.

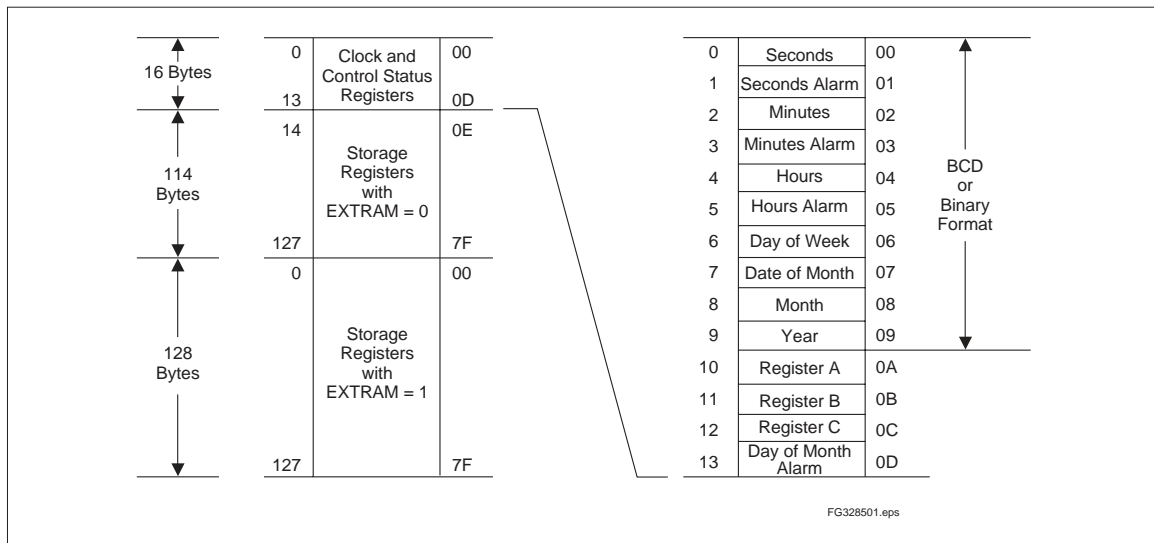

Figure 1. Address Map

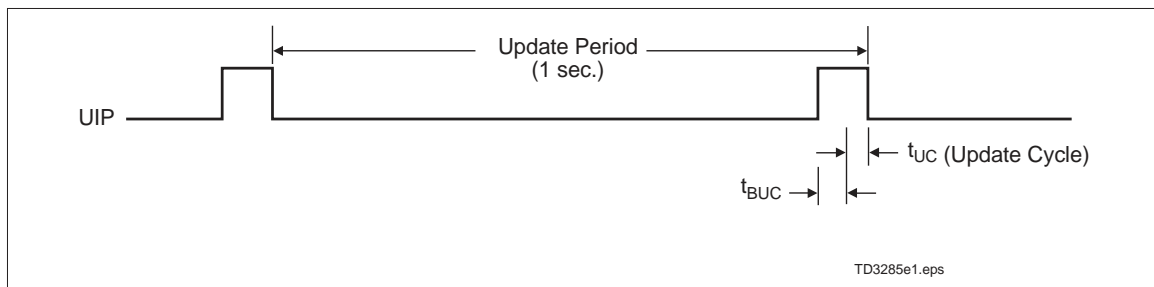

Figure 2. Update Period Timing and UIP

Programming the RTC

The time-of-day, alarm, and calendar bytes can be written in either the BCD or binary format (see Table 2).

These steps may be followed to program the time, alarm, and calendar:

1. Modify the contents of register B:
 - a. Write a 1 to the UTI bit to prevent transfers between RTC bytes and user buffer.
 - b. Write the appropriate value to the data format (DF) bit to select BCD or binary format for all time, alarm, and calendar bytes.
 - c. Write the appropriate value to the hour format (HF) bit.
2. Write new values to all the time, alarm, and calendar locations.
3. Clear the UTI bit to allow update transfers.

On the next update cycle, the RTC updates all 10 bytes in the selected format.

Table 2. Time, Alarm, and Calendar Formats

Address	RTC Bytes	Range		
		Decimal	Binary	Binary-Coded Decimal
0	Seconds	0–59	00H–3BH	00H–59H
1	Seconds alarm	0–59	00H–3BH	00H–59H
2	Minutes	0–59	00H–3BH	00H–59H
3	Minutes alarm	0–59	00H–3BH	00H–59H
4	Hours, 12-hour format	1–12	01H–0CH AM; 81H–8CH PM	01H–12H AM; 81H–92H PM
	Hours, 24-hour format	0–23	00H–17H	00H–23H
5	Hours alarm, 12-hour format	1–12	01H–0CH AM; 81H–8CH PM	01H–12H AM; 81H–92H PM
	Hours alarm, 24-hour format	0–23	00H–17H	00H–23H
6	Day of week (1=Sunday)	1–7	01H–07H	01H–07H
7	Day of month	1–31	01H–1FH	01H–31H
8	Month	1–12	01H–0CH	01H–12H
9	Year	0–99	00H–63H	00H–99H
D	Day of month alarm	1–31	01H–1FH	01–31H

bq3285ED/LD

32kHz Output

The bq3285ED/LD provides for a 32.768kHz output, and the output is always active whenever V_{CC} is valid ($V_{PFD} + t_{CSR}$). The bq3285ED/LD output is not affected by the bit settings in Register A. Time-keeping aspects, however, still require setting OS0-OS2.

Interrupts

The bq3285ED/LD allows three individually selected interrupt events to generate an interrupt request. These three interrupt events are:

- The periodic interrupt, programmable to occur once every 122 μ s to 500ms.
- The alarm interrupt, programmable to occur once per second to once per day, is active in battery-backup mode, providing a “wake-up” feature.
- The update-ended interrupt, which occurs at the end of each update cycle.

Each of the three interrupt events is enabled by an individual interrupt-enable bit in register B. When an event occurs, its event flag bit in register C is set. If the corresponding event enable bit is also set, then an interrupt request is generated. The interrupt request flag bit (INTF) of register C is set with every interrupt request. Reading register C clears all flag bits, including INTF, and makes \overline{INT} high-impedance.

Two methods can be used to process bq3285ED/LD interrupt events:

- Enable interrupt events and use the interrupt request output to invoke an interrupt service routine.
- Do not enable the interrupts and use a polling routine to periodically check the status of the flag bits.

The individual interrupt sources are described in detail in the following sections.

Table 3. Periodic Interrupt Rate

Register A Bits							Periodic Interrupt	
OSC2	OSC1	OSC0	RS3	RS2	RS1	RS0	Period	Units
0	1	0	0	0	0	0	None	
0	1	0	0	0	0	1	3.90625	ms
0	1	0	0	0	1	0	7.8125	ms
0	1	0	0	0	1	1	122.070	μ s
0	1	0	0	1	0	0	244.141	μ s
0	1	0	0	1	0	1	488.281	μ s
0	1	0	0	1	1	0	976.5625	μ s
0	1	0	0	1	1	1	1.95315	ms
0	1	0	1	0	0	0	3.90625	ms
0	1	0	1	0	0	1	7.8125	ms
0	1	0	1	0	1	0	15.625	ms
0	1	0	1	0	1	1	31.25	ms
0	1	0	1	1	0	0	62.5	ms
0	1	0	1	1	0	1	125	ms
0	1	0	1	1	1	0	250	ms
0	1	0	1	1	1	1	500	ms
0	1	1	X	X	X	X	same as above defined by RS3–RS0	

July 1997

Periodic Interrupt

If the periodic interrupt event is enabled by writing a 1 to the periodic interrupt enable bit (PIE) in register C, an interrupt request is generated once every $122\mu\text{s}$ to 500ms. The period between interrupts is selected with bits RS3-RS0 in register A (see Table 3).

Alarm Interrupt

The alarm interrupt is active in battery-backup mode, providing a “wake-up” capability. During each update cycle, the RTC compares the day-of-the-month, hours, minutes, and seconds bytes with the four corresponding alarm bytes. If a match of all bytes is found, the alarm interrupt event flag bit, AF in register C, is set to 1. If the alarm event is enabled, an interrupt request is generated.

An alarm byte may be removed from the comparison by setting it to a “don't care” state. The seconds, minutes, and hours alarm bytes are set to a “don't care” state by writing a 1 to each of its two most-significant bits. The day-of-the-month alarm byte is set to a “don't care” state by setting DA5–DA0, in register D, to all zeros. A “don't care” state may be used to select the frequency of alarm interrupt events as follows:

- If none of the four alarm bytes is “don't care,” the frequency is once per month, when day-of-the-month, hours, minutes, and seconds match.
- If only the day-of-the-month alarm byte is “don't care,” the frequency is once per day, when hours, minutes, and seconds match.
- If only the day-of-the-month and hour alarm byte is “don't care,” the frequency is once per hour, when minutes and seconds match.
- If only the day-of-the-month, hour and minute alarm bytes are “don't care,” the frequency is once per minute, when seconds match.

- If the day-of-the-month, hour, minute, and second alarm bytes are “don't care,” the frequency is once per second.

Update Cycle Interrupt

The update cycle ended flag bit (UF) in register C is set to a 1 at the end of an update cycle. If the update interrupt enable bit (UIE) of register B is 1, and the update transfer inhibit bit (UTI) in register B is 0, then an interrupt request is generated at the end of each update cycle.

Accessing RTC bytes

The EXTRAM pin must be low to access the RTC registers. Time and calendar bytes read during an update cycle may be in error. Three methods to access the time and calendar bytes without ambiguity are:

- Enable the update interrupt event to generate interrupt requests at the end of the update cycle. The interrupt handler has a maximum of 999ms to access the clock bytes before the next update cycle begins (see Figure 3).
- Poll the update-in-progress bit (UIP) in register A. If $\text{UIP} = 0$, the polling routine has a minimum of t_{BUC} time to access the clock bytes (see Figure 3).
- Use the periodic interrupt event to generate interrupt requests every t_{PI} time, such that $\text{UIP} = 1$ always occurs between the periodic interrupts. The interrupt handler has a minimum of $t_{\text{PI}}/2 + t_{\text{BUC}}$ time to access the clock bytes (see Figure 3).

Oscillator Control

When power is first applied to the bq3285ED/LD and V_{CC} is above V_{PFD} , the internal oscillator and frequency divider are turned on by writing a 010 pattern to bits 4 through 6 of register A. A pattern of 11X turns the oscillator on but keeps the frequency divider disabled. Any

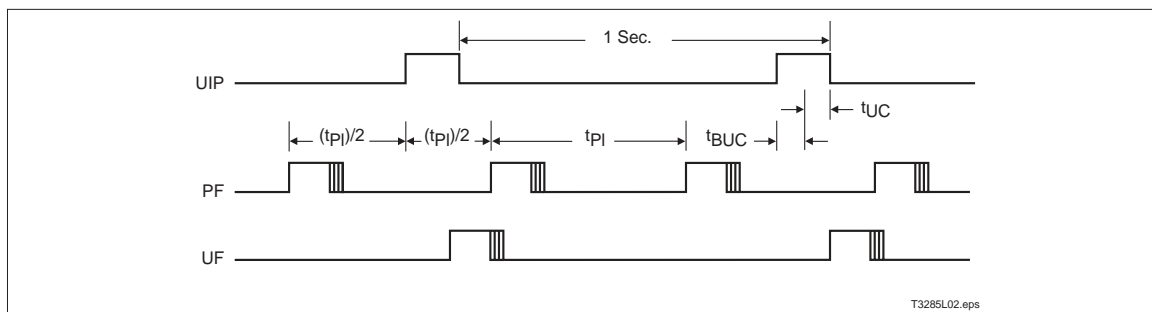

Figure 3. Update-Ended/Periodic Interrupt Relationship

bq3285ED/LD

other pattern to these bits keeps the oscillator off. A pattern of 010 must be set for the bq3285ED/LD to keep time in battery backup mode.

Power-Down/Power-Up Cycle

The bq3285ED and bq3285LD power-up/power-down cycles are different. The bq3285LD continuously monitors V_{CC} for out-of-tolerance. During a power failure, when V_{CC} falls below V_{PFD} (2.53V typical), the bq3285LD write-protects the clock and storage registers. The power source is switched to BC when V_{CC} is less than V_{PFD} and BC is greater than V_{PFD} , or when V_{CC} is less than V_{BC} and V_{BC} is less than V_{PFD} . RTC operation and storage data are sustained by a valid backup energy source. When V_{CC} is above V_{PFD} , the power source is V_{CC} . Write-protection continues for t_{CSR} time after V_{CC} rises above V_{PFD} .

The bq3285ED continuously monitors V_{CC} for out-of-tolerance. During a power failure, when V_{CC} falls below V_{PFD} (4.17V typical), the bq3285ED write-protects the clock and storage registers. When V_{CC} is below V_{BC} (3V typical), the power source is switched to BC. RTC operation and storage data are sustained by a valid backup energy source. When V_{CC} is above V_{BC} , the power source is V_{CC} . Write-protection continues for t_{CSR} time after V_{CC} rises above V_{PFD} .

Control/Status Registers

The four control/status registers of the bq3285ED/LD are accessible regardless of the status of the update cycle (see Table 4).

Register A

Register A Bits							
7	6	5	4	3	2	1	0
UIP	OS2	OS1	OS0	RS3	RS2	RS1	RS0

Register A programs:

- The frequency of the periodic event rate.
- Oscillator operation.
- Time-keeping

Register A provides:

- Status of the update cycle.

RS0–RS3 - Frequency Select

7	6	5	4	3	2	1	0
-	-	-	-	RS3	RS2	RS1	RS0

These bits select the periodic interrupt rate, as shown in Table 3.

OS0–OS2 - Oscillator Control

7	6	5	4	3	2	1	0
-	OS2	OS1	OS0	-	-	-	-

These three bits control the state of the oscillator and divider stages. A pattern of 010 or 011 enables RTC operation by turning on the oscillator and enabling the frequency divider. This pattern must be set to turn the oscillator on and to ensure that the bq3285ED/LD keeps time in battery-backup mode. A pattern of 11X turns the oscillator on, but keeps the frequency divider disabled. When 010 is written, the RTC begins its first update after 500ms.

Table 4. Control/Status Registers

Reg.	Loc. (Hex)	Read	Write	Bit Name and State on Reset															
				7 (MSB)	6		5	4		3	2		1	0 (LSB)					
A	0A	Yes	Yes ¹	UIP	na	OS2	na	OS1	na	OS0	na	RS3	na	RS2	na	RS1	na	RS0	na
B	0B	Yes	Yes	UTI	na	PIE	0	AIE	0	UIE	0	-	0	DF	na	HF	na	DSE	na
C	0C	Yes	No	INTF	0	PF	0	AF	0	UF	0	-	0	-	na	-	0	-	0
D	0D	Yes	Yes ²	VRT	na	-	0	DA5	na	DA4	na	DA3	na	DA2	na	DA1	na	DA0	na

Notes: na = not affected.

1. Except bit 7.
2. Except bits 6 and 7.

UIP - Update Cycle Status

7	6	5	4	3	2	1	0
UIP	-	-	-	-	-	-	-

This read-only bit is set prior to the update cycle. When UIP equals 1, an RTC update cycle may be in progress. UIP is cleared at the end of each update cycle. This bit is also cleared when the update transfer inhibit (UTI) bit in register B is 1.

Register B

Register B Bits							
7	6	5	4	3	2	1	0
UTI	PIE	AIE	UIE	-	DF	HF	DSE

Register B enables:

- Update cycle transfer operation
- Interrupt events
- Daylight saving adjustment

Register B selects:

- Clock and calendar data formats

All bits of register B are read/write.

Bit 3 - Unused Bit.

DSE - Daylight Saving Enable

7	6	5	4	3	2	1	0
-	-	-	-	-	-	-	DSE

This bit enables daylight-saving time adjustments when written to 1:

- On the last Sunday in October, the first time the bq3285ED/LD increments past 1:59:59 AM, the time falls back to 1:00:00 AM.
- On the first Sunday in April, the time springs forward from 2:00:00 AM to 3:00:00 AM.

HF - Hour Format

7	6	5	4	3	2	1	0
-	-	-	-	-	-	HF	-

This bit selects the time-of-day and alarm hour format:

- 1 = 24-hour format
- 0 = 12-hour format

July 1997

DF - Data Format

7	6	5	4	3	2	1	0
-	-	-	-	-	DF	-	-

This bit selects the numeric format in which the time, alarm, and calendar bytes are represented:

- 1 = Binary
- 0 = BCD

UIE - Update Cycle Interrupt Enable

7	6	5	4	3	2	1	0
-	-	-	UIE	-	-	-	-

This bit enables an interrupt request due to an update ended interrupt event:

- 1 = Enabled
- 0 = Disabled

The UIE bit is automatically cleared when the UTI bit equals 1.

AIE - Alarm Interrupt Enable

7	6	5	4	3	2	1	0
-	-	AIE	-	-	-	-	-

This bit enables an interrupt request due to an alarm interrupt event:

- 1 = Enabled
- 0 = Disabled

PIE - Periodic Interrupt Enable

7	6	5	4	3	2	1	0
-	PIE	-	-	-	-	-	-

This bit enables an interrupt request due to a periodic interrupt event:

- 1 = Enabled
- 0 = Disabled

UTI - Update Transfer Inhibit

7	6	5	4	3	2	1	0
UTI	-	-	-	-	-	-	-

bq3285ED/LD

This bit inhibits the transfer of RTC bytes to the user buffer:

- 1 = Inhibits transfer and clears UIE
- 0 = Allows transfer

Register C

Register C Bits							
7	6	5	4	3	2	1	0
INTF	PF	AF	UF	0	-	0	0

Register C is the read-only event status register.

Bits 0, 1, 2, 3 - Unused Bits

7	6	5	4	3	2	1	0
-	-	-	-	0	-	0	0

These bits are always set to 0.

UF - Update Event Flag

7	6	5	4	3	2	1	0
-	-	-	UF	-	-	-	-

This bit is set to a 1 at the end of the update cycle. Reading register C clears this bit.

AF - Alarm Event Flag

7	6	5	4	3	2	1	0
-	-	AF	-	-	-	-	-

This bit is set to a 1 when an alarm event occurs. Reading register C clears this bit.

PF - Periodic Event Flag

7	6	5	4	3	2	1	0
-	PF	-	-	-	-	-	-

This bit is set to a 1 every t_{PI} time, where t_{PI} is the time period selected by the settings of RS0–RS3 in register A. Reading register C clears this bit.

INTF - Interrupt Request Flag

7	6	5	4	3	2	1	0
INTF	-	-	-	-	-	-	-

This flag is set to a 1 when any of the following is true:

AIE = 1 and AF = 1

PIE = 1 and PF = 1

UIE = 1 and UF = 1

Reading register C clears this bit.

Register D

Register D Bits							
7	6	5	4	3	2	1	0
VRT	0	DA5	DA4	DA3	DA2	DA1	DA0

Register D provides for the read-only data integrity status bit, and the day-of-the-month alarm.

Bits 6 - Unused Bit

7	6	5	4	3	2	1	0
-	0	-	-	-	-	-	-

This bit is always set to 0.

VRT - Valid RAM and Time

7	6	5	4	3	2	1	0
VRT	-	-	-	-	-	-	-

1 = Valid backup energy source

0 = Backup energy source is depleted

When the backup energy source is depleted (VRT = 0), data integrity of the RTC and storage registers is not guaranteed.

DA0–DA5

7	6	5	4	3	2	1	0
-	-	DA5	DA4	DA3	DA2	DA1	DA0-

These bits store the value for the day-of-the-month alarm. If DA0–DA5 are set to zero, then the day-of-the-month alarm is disabled. These bits are not affected by a reset.

Absolute Maximum Ratings—bq3285ED

Symbol	Parameter	Value	Unit	Conditions
V _{CC}	DC voltage applied on V _{CC} relative to V _{SS}	-0.3 to 7.0	V	
V _T	DC voltage applied on any pin excluding V _{CC} relative to V _{SS}	-0.3 to 7.0	V	V _T ≤ V _{CC} + 0.3
T _{OPR}	Operating temperature	0 to +70	°C	Commercial
T _{STG}	Storage temperature	-55 to +125	°C	
T _{BIAS}	Temperature under bias	-40 to +85	°C	
T _{SOLDER}	Soldering temperature	260	°C	For 10 seconds

Note: Permanent device damage may occur if **Absolute Maximum Ratings** are exceeded. Functional operation should be limited to the Recommended DC Operating Conditions detailed in this data sheet. Exposure to conditions beyond the operational limits for extended periods of time may affect device reliability.

Absolute Maximum Ratings—bq3285LD

Symbol	Parameter	Value	Unit	Conditions
V _{CC}	DC voltage applied on V _{CC} relative to V _{SS}	-0.3 to 7.0	V	
V _T	DC voltage applied on any pin excluding V _{CC} relative to V _{SS}	-0.3 to 7.0	V	V _T ≤ V _{CC} + 0.3
T _{OPR}	Operating temperature	0 to +70	°C	Commercial
T _{STG}	Storage temperature	-55 to +125	°C	
T _{BIAS}	Temperature under bias	-40 to +85	°C	
T _{SOLDER}	Soldering temperature	260	°C	For 10 seconds

Note: Permanent device damage may occur if **Absolute Maximum Ratings** are exceeded. Functional operation should be limited to the Recommended DC Operating Conditions detailed in this data sheet. Exposure to conditions beyond the operational limits for extended periods of time may affect device reliability.

bq3285ED/LD

Recommended DC Operating Conditions—bq3285ED ($T_A = T_{OPR}$)

Symbol	Parameter	Minimum	Typical	Maximum	Unit
V _{CC}	Supply voltage	4.5	5.0	5.5	V
V _{SS}	Supply voltage	0	0	0	V
V _{IL}	Input low voltage	-0.3	-	0.8	V
V _{IH}	Input high voltage	2.2	-	V _{CC} + 0.3	V
V _{BC}	Backup cell voltage	2.4	-	4.0	V

Note: Typical values indicate operation at $T_A = 25^\circ\text{C}$.

Recommended DC Operating Conditions—bq3285LD ($T_A = T_{OPR}$)

Symbol	Parameter	Minimum	Typical	Maximum	Unit
V _{CC}	Supply voltage	2.7	3.0	5.5	V
V _{SS}	Supply voltage	0	0	0	V
V _{IL}	Input low voltage	-0.3	-	0.6	V
V _{IH}	Input high voltage	2.2	-	V _{CC} + 0.3	V
V _{BC}	Backup cell voltage	2.4	-	4.0	V

Note: Typical values indicate operation at $T_A = 25^\circ\text{C}$.

Crystal Specifications—bq3285ED/LD (DT-26 or Equivalent)

Symbol	Parameter	Minimum	Typical	Maximum	Unit
f ₀	Oscillation frequency	-	32.768	-	kHz
C _L	Load capacitance	-	6	-	pF
T _P	Temperature turnover point	20	25	30	°C
k	Parabolic curvature constant	-	-	-0.042	ppm/°C
Q	Quality factor	40,000	70,000	-	
R ₁	Series resistance	-	-	45	KΩ
C ₀	Shunt capacitance	-	1.1	1.8	pF
C ₀ /C ₁	Capacitance ratio	-	430	600	
D _L	Drive level	-	-	1	μW
Δf/f ₀	Aging (first year at 25°C)	-	1	-	ppm

July 1997

DC Electrical Characteristics—bq3285ED ($T_A = T_{OPR}$, $V_{CC} = 5V$)

Symbol	Parameter	Minimum	Typical	Maximum	Unit	Conditions/Notes
I _{LI}	Input leakage current	-	-	± 1	μA	V _{IN} = V _{SS} to V _{CC}
I _{LO}	Output leakage current	-	-	± 1	μA	AD ₀ –AD ₇ and \overline{INT} in high impedance, V _{OUT} = V _{SS} to V _{CC}
V _{OH}	Output high voltage	2.4	-	-	V	I _{OH} = -2.0 mA
V _{OL}	Output low voltage	-	-	0.4	V	I _{OL} = 4.0 mA
I _{CC}	Operating supply current	-	7	15	mA	Min. cycle, duty = 100%, I _{OH} = 0mA, I _{OL} = 0mA
I _{CCSB}	Standby supply current	-	300	-	μA	V _{IN} = V _{SS} or V _{CC} , CS ≥ V _{CC} - 0.2
V _{SO}	Supply switch-over voltage	-	V _{BC}	-	V	
I _{CCB}	Battery operation current	-	0.4	0.55	μA	V _{BC} = 3V, T _A = 25°C
V _{PF}	Power-fail-detect voltage	4.0	4.17	4.35	V	
I _{RCL}	Input current when $\overline{RCL} = V_{SS}$.	-	-	185	μA	Internal 30K pull-up
I _{MOTH}	Input current when MOT = V _{CC}	-	-	-185	μA	Internal 30K pull-down
	Input current when MOT = V _{SS}	-	-	0	μA	Internal 30K pull-down
I _{EXTRAM}	Input current when EXTRAM = V _{CC}	-	-	-185	μA	Internal 30K pull-down
	Input current when EXTRAM = V _{SS}	-	-	0	μA	Internal 30K pull-down

Note: Typical values indicate operation at T_A = 25°C, V_{CC} = 5V or V_{BC} = 3V.

bq3285ED/LD

DC Electrical Characteristics—bq3285LD ($T_A = T_{OPR}$, $V_{CC} = 3V$)

Symbol	Parameter	Minimum	Typical ¹	Maximum	Unit	Conditions/Notes
I_{LI}	Input leakage current	-	-	± 1	μA	$V_{IN} = V_{SS}$ to V_{CC}
I_{LO}	Output leakage current	-	-	± 1	μA	AD_0 – AD_7 and \overline{INT} in high impedance, $V_{OUT} = V_{SS}$ to V_{CC}
V_{OH}	Output high voltage	2.2	-	-	V	$I_{OH} = -1.0$ mA
V_{OL}	Output low voltage	-	-	0.4	V	$I_{OL} = 2.0$ mA
I_{CC}	Operating supply current	-	5 ²	9	mA	Min. cycle, duty = 100%, $I_{OH} = 0$ mA, $I_{OL} = 0$ mA
I_{CCSB}	Standby supply current	-	100 ³	-	μA	$V_{IN} = V_{SS}$ or V_{CC} , $CS \geq V_{CC} - 0.2$
V_{SO}	Supply switch-over voltage	-	V_{PFD}	-	V	$V_{BC} > V_{PFD}$
		-	V_{BC}	-	V	$V_{BC} < V_{PFD}$
I_{CCB}	Battery operation current	-	0.4	0.55	μA	$V_{BC} = 3V$, $T_A = 25^\circ C$, $V_{CC} < V_{BC}$
V_{PFD}	Power-fail-detect voltage	2.4	2.53	2.65	V	
I_{RCL}	Input current when $\overline{RCL} = V_{SS}$.	-	-	120	μA	Internal 30K pull-up
I_{MOTH}	Input current when $MOT = V_{CC}$	-	-	-120	μA	Internal 30K pull-down
	Input current when $MOT = V_{SS}$	-	-	0	μA	Internal 30K pull-down
I_{XTRAM}	Input current when $EXTRAM = V_{CC}$	-	-	-120	μA	Internal 30K pull-down
	Input current when $EXTRAM = V_{SS}$	-	-	0	μA	Internal 30K pull-down

- Notes:**
1. Typical values indicate operation at $T_A = 25^\circ C$, $V_{CC} = 3V$.
 2. 7mA at $V_{CC} = 5V$
 3. 300 μA at $V_{CC} = 5V$

Capacitance—bq3285ED/LD ($T_A = 25^\circ\text{C}$, $F = 1\text{MHz}$, $V_{CC} = 5.0\text{V}$)

Symbol	Parameter	Minimum	Typical	Maximum	Unit	Conditions
C_{LO}	Input/output capacitance	-	-	7	pF	$V_{OUT} = 0\text{V}$
C_{IN}	Input capacitance	-	-	5	pF	$V_{IN} = 0\text{V}$

Note: This parameter is sampled and not 100% tested. It does not include the X1 or X2 pin.

AC Test Conditions—bq3285ED

Parameter	Test Conditions
Input pulse levels	0 to 3.0 V
Input rise and fall times	5 ns
Input and output timing reference levels	1.5 V (unless otherwise specified)
Output load (including scope and jig)	See Figures 4 and 5

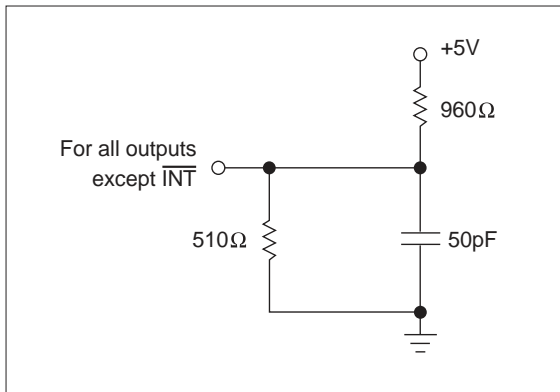

Figure 4. Output Load—bq3285ED

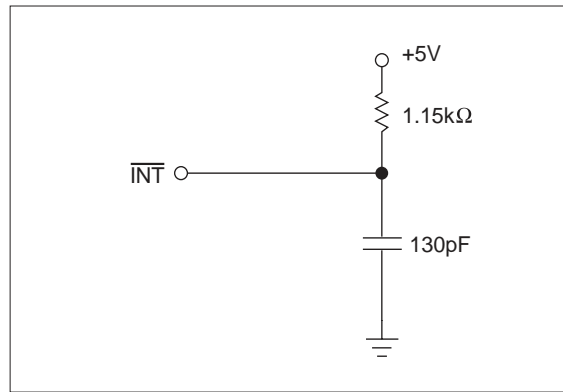

Figure 5. Output Load—bq3285ED

bq3285ED/LD

AC Test Conditions—bq3285LD

Parameter	Test Conditions
Input pulse levels	0 to 2.3 V, $V_{CC} = 3V^1$
Input rise and fall times	5 ns
Input and output timing reference levels	1.2 V (unless otherwise specified)
Output load (including scope and jig)	See Figures 6 and 7

Note: 1. For 5V timing, please refer to bq3285ED.

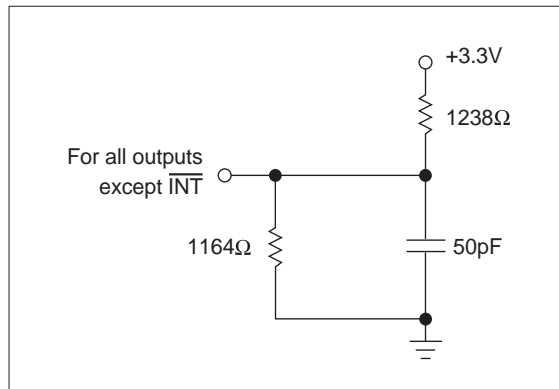

Figure 6. Output Load—bq3285LD

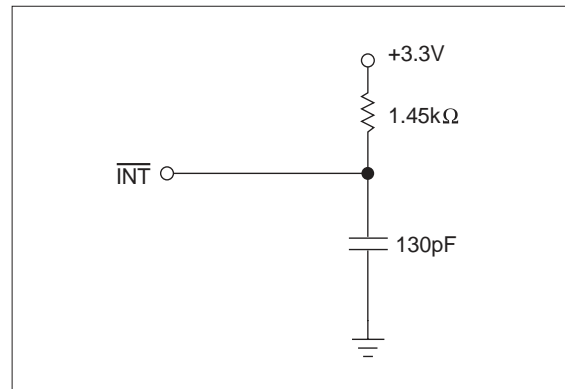

Figure 7. Output Load B—bq3285LD

Read/Write Timing—bq3285ED ($T_A = T_{OPR}$, $V_{CC} = 5V$)

Symbol	Parameter	Minimum	Typical	Maximum	Unit	Notes
t _{CYC}	Cycle time	160	-	-	ns	
t _{DSL}	DS low or $\overline{RD}/\overline{WR}$ high time	80	-	-	ns	
t _{DSH}	DS high or $\overline{RD}/\overline{WR}$ low time	55	-	-	ns	
t _{RWH}	R/\overline{W} hold time	0	-	-	ns	
t _{RWS}	R/\overline{W} setup time	10	-	-	ns	
t _{CS}	Chip select setup time	5	-	-	ns	
t _{CH}	Chip select hold time	0	-	-	ns	
t _{DHR}	Read data hold time	0	-	25	ns	
t _{DHW}	Write data hold time	0	-	-	ns	
t _{AS}	Address setup time	20	-	-	ns	
t _{AH}	Address hold time	5	-	-	ns	
t _{DAS}	Delay time, DS to AS rise	10	-	-	ns	
t _{ASW}	Pulse width, AS high	30	-	-	ns	
t _{ASD}	Delay time, AS to DS rise ($\overline{RD}/\overline{WR}$ fall)	35	-	-	ns	
t _{OD}	Output data delay time from DS rise (RD fall)	-	-	50	ns	
t _{DW}	Write data setup time	30	-	-	ns	
t _{BCU}	Delay time before update cycle	-	244	-	μ s	
t _{PI}	Periodic interrupt time interval	-	-	-	-	See Table 3
t _{UC}	Time of update cycle	-	1	-	μ s	

bq3285ED/LD

Read/Write Timing—bq3285LD ($T_A = T_{OPR}$, $V_{CC} = 3V$)

Symbol	Parameter	Minimum	Typical	Maximum	Unit	Notes
t _{CYC}	Cycle time	270	-	-	ns	
t _{DSL}	DS low or $\overline{RD}/\overline{WR}$ high time	135	-	-	ns	
t _{DSH}	DS high or $\overline{RD}/\overline{WR}$ low time	90	-	-	ns	
t _{RWH}	R/\overline{W} hold time	0	-	-	ns	
t _{RWS}	R/\overline{W} setup time	15	-	-	ns	
t _{CS}	Chip select setup time	8	-	-	ns	
t _{CH}	Chip select hold time	0	-	-	ns	
t _{DHR}	Read data hold time	0	-	40	ns	
t _{DHW}	Write data hold time	0	-	-	ns	
t _{AS}	Address setup time	30	-	-	ns	
t _{AH}	Address hold time	15	-	-	ns	
t _{DAS}	Delay time, DS to AS rise	15	-	-	ns	
t _{ASW}	Pulse width, AS high	50	-	-	ns	
t _{ASD}	Delay time, AS to DS rise ($\overline{RD}/\overline{WR}$ fall)	55	-	-	ns	
t _{OD}	Output data delay time from DS rise (\overline{RD} fall)	-	-	100	ns	
t _{DW}	Write data setup time	50	-	-	ns	
t _{BUC}	Delay time before update cycle	-	244	-	μs	
t _{PI}	Periodic interrupt time interval	-	-	-	-	See Table 3
t _{UC}	Time of update cycle	-	1	-	μs	

Motorola Bus Read/Write Timing—bq3285ED/LD

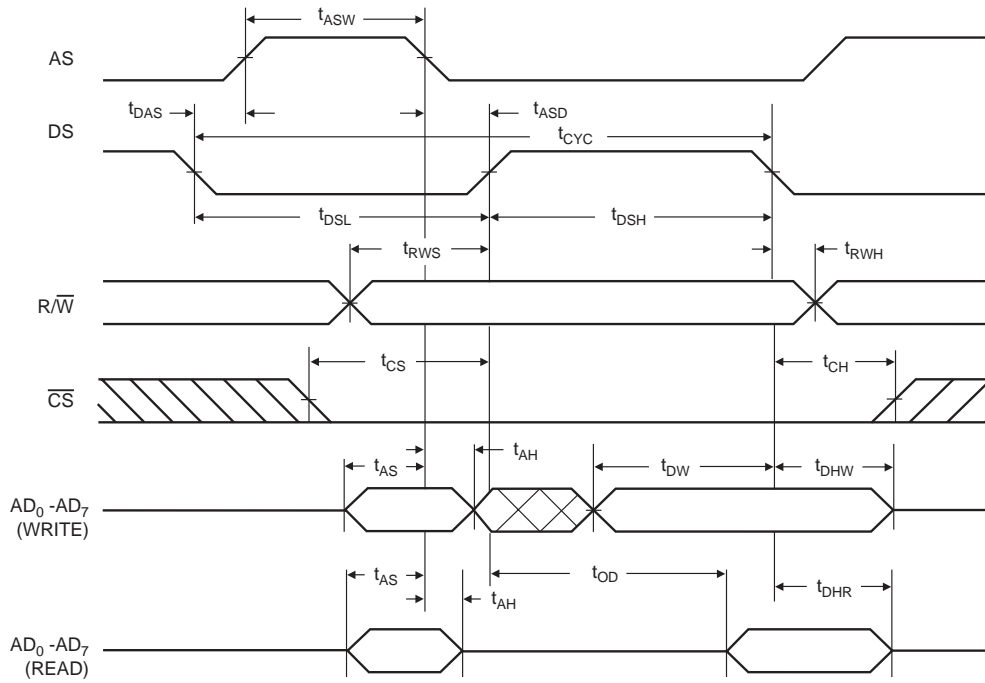

T3285L03.eps

bq3285ED/LD

Intel Bus Read Timing—bq3285ED/LD

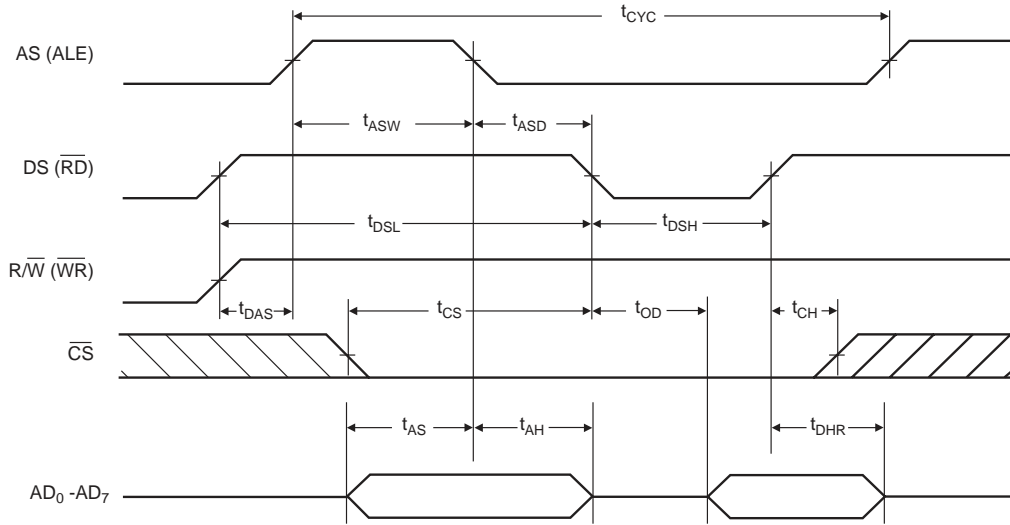

T3285L04.eps

Intel Bus Write Timing—bq3285ED/LD

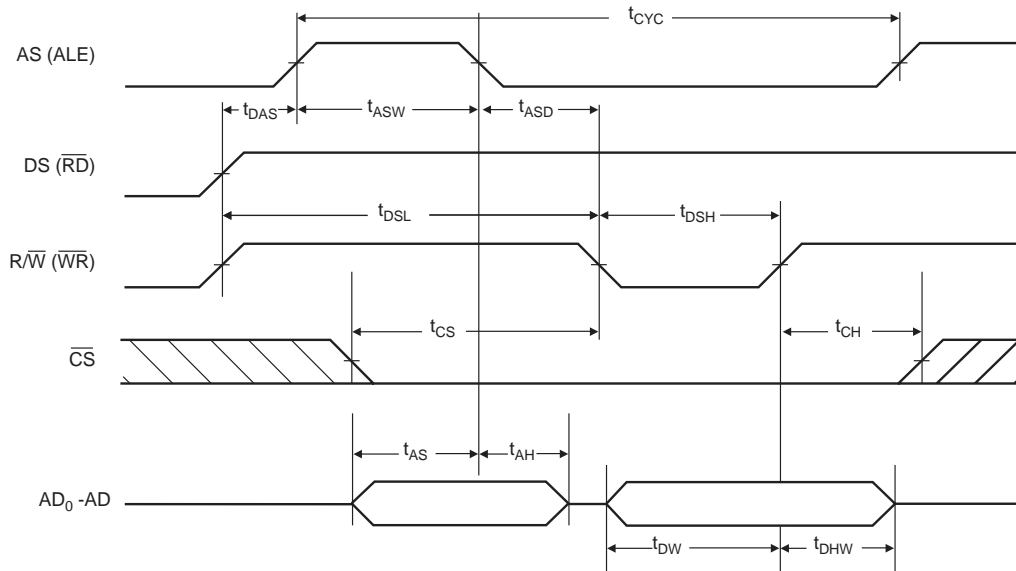

T3285L05.eps

July 1997

Power-Down/Power-Up Timing—bq3285ED ($T_A = T_{OPR}$)

Symbol	Parameter	Minimum	Typical	Maximum	Unit	Conditions
t_F	V_{CC} slew from 4.5V to 0V	300	-	-	μs	
t_R	V_{CC} slew from 0V to 4.5V	100	-	-	μs	
t_{CSR}	\overline{CS} at V_{IH} after power-up	20	-	200	ms	Internal write-protection period after V_{CC} passes V_{PFD} on power-up.

Caution: Negative undershoots below the absolute maximum rating of -0.3V in battery-backup mode may affect data integrity.

Power-Down/Power-Up Timing—bq3285ED

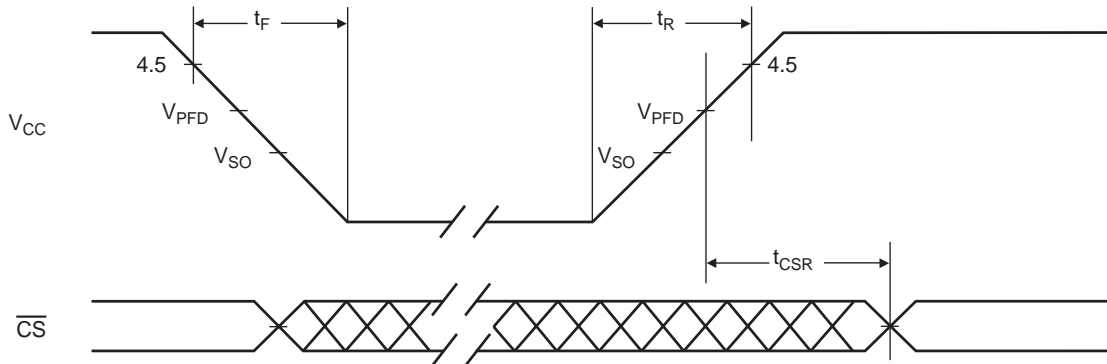

T3285L08.eps

bq3285ED/LD

Power-Down/Power-Up Timing—bq3285LD ($T_A = T_{OPR}$)

Symbol	Parameter	Minimum	Typical	Maximum	Unit	Conditions
t_F	V_{CC} slew from 2.7V to 0V	300	-	-	μs	
t_R	V_{CC} slew from 0V to 2.7V	100	-	-	μs	
t_{CSR}	\overline{CS} at V_{IH} after power-up	20	-	200	ms	Internal write-protection period after V_{CC} passes V_{PFD} on power-up.

Caution: Negative undershoots below the absolute maximum rating of -0.3V in battery-backup mode may affect data integrity.

Power-Down/Power-Up Timing—bq3285LD

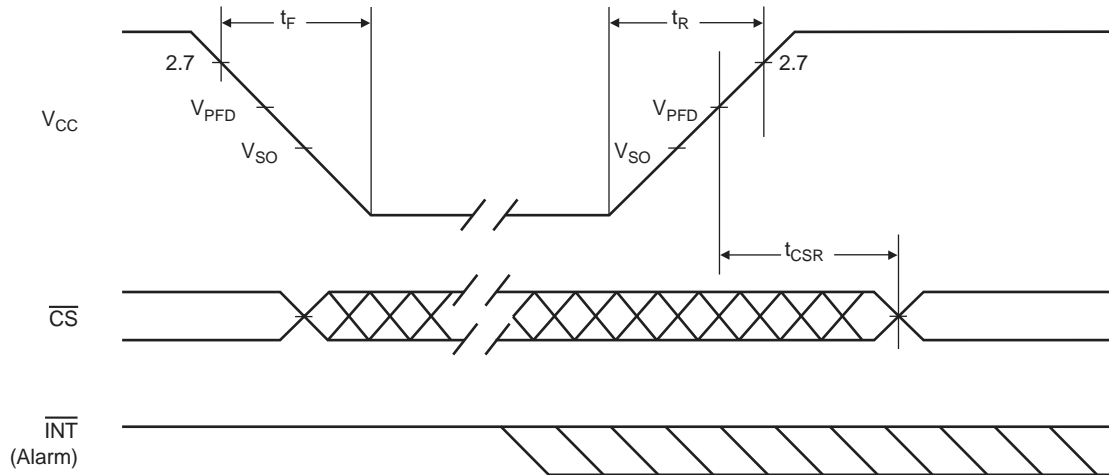

T3285L06.eps

Interrupt Delay Timing—bq3285ED/LD ($T_A = T_{OPR}$)

Symbol	Parameter	Minimum	Typical	Maximum	Unit
t_{RSW}	Reset pulse width	5	-	-	μs
t_{IRR}	\overline{INT} release from \overline{RST}	-	-	2	μs
t_{IRD}	\overline{INT} release from DS	-	-	2	μs

Interrupt Delay Timing—bq3285ED/LD

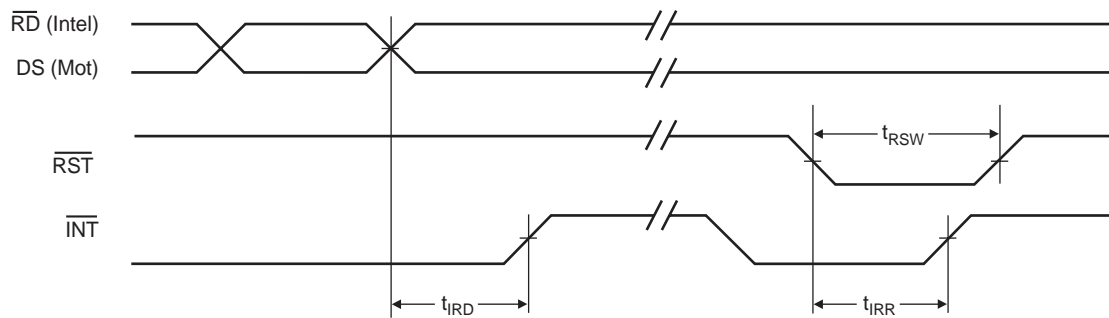

T3285L07.eps

PACKAGING INFORMATION

Orderable Device	Status (1)	Package Type	Package Drawing	Pins	Package Qty	Eco Plan (2)	Lead/Ball Finish (6)	MSL Peak Temp (3)	Op Temp (°C)	Device Marking (4/5)	Samples
BQ3285LDSS	LIFEBUY	SSOP	DBQ	24		TBD	Call TI	Call TI	0 to 70	3285LDSS -A2	
BQ3285LDSSTR	LIFEBUY	SSOP	DBQ	24		TBD	Call TI	Call TI	0 to 70	3285LDSS -A2	
BQ3285LDSSTRG4	LIFEBUY	SSOP	DBQ	24		TBD	Call TI	Call TI	0 to 70	3285LDSS -A2	

(1) The marketing status values are defined as follows:

ACTIVE: Product device recommended for new designs.

LIFEBUY: TI has announced that the device will be discontinued, and a lifetime-buy period is in effect.

NRND: Not recommended for new designs. Device is in production to support existing customers, but TI does not recommend using this part in a new design.

PREVIEW: Device has been announced but is not in production. Samples may or may not be available.

OBSELETE: TI has discontinued the production of the device.

(2) **RoHS:** TI defines "RoHS" to mean semiconductor products that are compliant with the current EU RoHS requirements for all 10 RoHS substances, including the requirement that RoHS substance do not exceed 0.1% by weight in homogeneous materials. Where designed to be soldered at high temperatures, "RoHS" products are suitable for use in specified lead-free processes. TI may reference these types of products as "Pb-Free".

RoHS Exempt: TI defines "RoHS Exempt" to mean products that contain lead but are compliant with EU RoHS pursuant to a specific EU RoHS exemption.

Green: TI defines "Green" to mean the content of Chlorine (Cl) and Bromine (Br) based flame retardants meet JS709B low halogen requirements of <=1000ppm threshold. Antimony trioxide based flame retardants must also meet the <=1000ppm threshold requirement.

(3) MSL, Peak Temp. - The Moisture Sensitivity Level rating according to the JEDEC industry standard classifications, and peak solder temperature.

(4) There may be additional marking, which relates to the logo, the lot trace code information, or the environmental category on the device.

(5) Multiple Device Markings will be inside parentheses. Only one Device Marking contained in parentheses and separated by a "-" will appear on a device. If a line is indented then it is a continuation of the previous line and the two combined represent the entire Device Marking for that device.

(6) Lead/Ball Finish - Orderable Devices may have multiple material finish options. Finish options are separated by a vertical ruled line. Lead/Ball Finish values may wrap to two lines if the finish value exceeds the maximum column width.

Important Information and Disclaimer:The information provided on this page represents TI's knowledge and belief as of the date that it is provided. TI bases its knowledge and belief on information provided by third parties, and makes no representation or warranty as to the accuracy of such information. Efforts are underway to better integrate information from third parties. TI has taken and continues to take reasonable steps to provide representative and accurate information but may not have conducted destructive testing or chemical analysis on incoming materials and chemicals. TI and TI suppliers consider certain information to be proprietary, and thus CAS numbers and other limited information may not be available for release.

In no event shall TI's liability arising out of such information exceed the total purchase price of the TI part(s) at issue in this document sold by TI to Customer on an annual basis.

IMPORTANT NOTICE

Texas Instruments Incorporated (TI) reserves the right to make corrections, enhancements, improvements and other changes to its semiconductor products and services per JESD46, latest issue, and to discontinue any product or service per JESD48, latest issue. Buyers should obtain the latest relevant information before placing orders and should verify that such information is current and complete.

TI's published terms of sale for semiconductor products (<http://www.ti.com/sc/docs/stdterms.htm>) apply to the sale of packaged integrated circuit products that TI has qualified and released to market. Additional terms may apply to the use or sale of other types of TI products and services.

Reproduction of significant portions of TI information in TI data sheets is permissible only if reproduction is without alteration and is accompanied by all associated warranties, conditions, limitations, and notices. TI is not responsible or liable for such reproduced documentation. Information of third parties may be subject to additional restrictions. Resale of TI products or services with statements different from or beyond the parameters stated by TI for that product or service voids all express and any implied warranties for the associated TI product or service and is an unfair and deceptive business practice. TI is not responsible or liable for any such statements.

Buyers and others who are developing systems that incorporate TI products (collectively, "Designers") understand and agree that Designers remain responsible for using their independent analysis, evaluation and judgment in designing their applications and that Designers have full and exclusive responsibility to assure the safety of Designers' applications and compliance of their applications (and of all TI products used in or for Designers' applications) with all applicable regulations, laws and other applicable requirements. Designer represents that, with respect to their applications, Designer has all the necessary expertise to create and implement safeguards that (1) anticipate dangerous consequences of failures, (2) monitor failures and their consequences, and (3) lessen the likelihood of failures that might cause harm and take appropriate actions. Designer agrees that prior to using or distributing any applications that include TI products, Designer will thoroughly test such applications and the functionality of such TI products as used in such applications.

TI's provision of technical, application or other design advice, quality characterization, reliability data or other services or information, including, but not limited to, reference designs and materials relating to evaluation modules, (collectively, "TI Resources") are intended to assist designers who are developing applications that incorporate TI products; by downloading, accessing or using TI Resources in any way, Designer (individually or, if Designer is acting on behalf of a company, Designer's company) agrees to use any particular TI Resource solely for this purpose and subject to the terms of this Notice.

TI's provision of TI Resources does not expand or otherwise alter TI's applicable published warranties or warranty disclaimers for TI products, and no additional obligations or liabilities arise from TI providing such TI Resources. TI reserves the right to make corrections, enhancements, improvements and other changes to its TI Resources. TI has not conducted any testing other than that specifically described in the published documentation for a particular TI Resource.

Designer is authorized to use, copy and modify any individual TI Resource only in connection with the development of applications that include the TI product(s) identified in such TI Resource. NO OTHER LICENSE, EXPRESS OR IMPLIED, BY ESTOPPEL OR OTHERWISE TO ANY OTHER TI INTELLECTUAL PROPERTY RIGHT, AND NO LICENSE TO ANY TECHNOLOGY OR INTELLECTUAL PROPERTY RIGHT OF TI OR ANY THIRD PARTY IS GRANTED HEREIN, including but not limited to any patent right, copyright, mask work right, or other intellectual property right relating to any combination, machine, or process in which TI products or services are used. Information regarding or referencing third-party products or services does not constitute a license to use such products or services, or a warranty or endorsement thereof. Use of TI Resources may require a license from a third party under the patents or other intellectual property of the third party, or a license from TI under the patents or other intellectual property of TI.

TI RESOURCES ARE PROVIDED "AS IS" AND WITH ALL FAULTS. TI DISCLAIMS ALL OTHER WARRANTIES OR REPRESENTATIONS, EXPRESS OR IMPLIED, REGARDING RESOURCES OR USE THEREOF, INCLUDING BUT NOT LIMITED TO ACCURACY OR COMPLETENESS, TITLE, ANY EPIDEMIC FAILURE WARRANTY AND ANY IMPLIED WARRANTIES OF MERCHANTABILITY, FITNESS FOR A PARTICULAR PURPOSE, AND NON-INFRINGEMENT OF ANY THIRD PARTY INTELLECTUAL PROPERTY RIGHTS. TI SHALL NOT BE LIABLE FOR AND SHALL NOT DEFEND OR INDEMNIFY DESIGNER AGAINST ANY CLAIM, INCLUDING BUT NOT LIMITED TO ANY INFRINGEMENT CLAIM THAT RELATES TO OR IS BASED ON ANY COMBINATION OF PRODUCTS EVEN IF DESCRIBED IN TI RESOURCES OR OTHERWISE. IN NO EVENT SHALL TI BE LIABLE FOR ANY ACTUAL, DIRECT, SPECIAL, COLLATERAL, INDIRECT, PUNITIVE, INCIDENTAL, CONSEQUENTIAL OR EXEMPLARY DAMAGES IN CONNECTION WITH OR ARISING OUT OF TI RESOURCES OR USE THEREOF, AND REGARDLESS OF WHETHER TI HAS BEEN ADVISED OF THE POSSIBILITY OF SUCH DAMAGES.

Unless TI has explicitly designated an individual product as meeting the requirements of a particular industry standard (e.g., ISO/TS 16949 and ISO 26262), TI is not responsible for any failure to meet such industry standard requirements.

Where TI specifically promotes products as facilitating functional safety or as compliant with industry functional safety standards, such products are intended to help enable customers to design and create their own applications that meet applicable functional safety standards and requirements. Using products in an application does not by itself establish any safety features in the application. Designers must ensure compliance with safety-related requirements and standards applicable to their applications. Designer may not use any TI products in life-critical medical equipment unless authorized officers of the parties have executed a special contract specifically governing such use. Life-critical medical equipment is medical equipment where failure of such equipment would cause serious bodily injury or death (e.g., life support, pacemakers, defibrillators, heart pumps, neurostimulators, and implantables). Such equipment includes, without limitation, all medical devices identified by the U.S. Food and Drug Administration as Class III devices and equivalent classifications outside the U.S.

TI may expressly designate certain products as completing a particular qualification (e.g., Q100, Military Grade, or Enhanced Product). Designers agree that it has the necessary expertise to select the product with the appropriate qualification designation for their applications and that proper product selection is at Designers' own risk. Designers are solely responsible for compliance with all legal and regulatory requirements in connection with such selection.

Designer will fully indemnify TI and its representatives against any damages, costs, losses, and/or liabilities arising out of Designer's non-compliance with the terms and provisions of this Notice.