

MCT8316Z Sensored Trapezoidal Integrated FET BLDC Motor Driver

1 Features

- Three-phase BLDC motor driver with integrated Sensored Trapezoidal control
 - Hall Sensor based Trapezoidal (120°) commutation
 - Supports Analog or Digital Hall inputs
 - Configurable PWM modulation: Synchronous/Asynchronous
 - Cycle-by-cycle current limit to limit phase current
 - Supports up to 200-kHz PWM frequency
 - Active Demagnetization to reduce power losses
- 4.5-V to 35-V operating voltage (40-V abs max)
- High output current capability: 8-A Peak
- Low MOSFET on-state resistance
 - 95-mΩ $R_{DS(ON)}$ (HS + LS) at $T_A = 25^\circ\text{C}$
- Low power sleep mode
 - 1.5-μA at $V_{VM} = 24\text{-V}$, $T_A = 25^\circ\text{C}$
- Integrated built-in current sense
 - Doesn't require external current sense resistors
- Flexible device configuration options
 - MCT8316ZR: 5-MHz 16-bit SPI interface for device configuration and fault status
 - MCT8316ZT: Hardware pin based configuration
- Supports 1.8-V, 3.3-V, and 5-V logic inputs
- Built-in 3.3-V (5%), 30-mA LDO regulator
- Built-in 3.3-V/5-V, 200-mA buck regulator
- Delay compensation reduces duty cycle distortion
- Suite of integrated protection features
 - Supply undervoltage lockout (UVLO)
 - Charge pump undervoltage (CPUV)
 - Overcurrent protection (OCP)
 - Motor lock protection
 - Thermal warning and shutdown (OTW/OTSD)
 - Fault condition indication pin (nFAULT)
 - Optional fault diagnostics over SPI interface

2 Applications

- [Brushless-DC \(BLDC\) Motor Modules](#)
- [Small home appliances](#)
- [HVAC motors](#)
- [Office automation machines](#)
- [Factory automation and robotics](#)

3 Description

The MCT8316Z provides a single-chip code-free sensored trapezoidal solution for customers driving 12- to 24-V brushless-DC motors. The MCT8316Z integrates three 1/2-H bridges with 40-V absolute maximum capability and a very low RDS(ON) of 95 mΩ (high-side and low-side combined) to enable high power drive capability. Current is sensed using an integrated current sensing feature which eliminates the need for external sense resistors. Power management features of an adjustable buck regulator and LDO generate the necessary voltage rails for the device and can be used to power external circuits.

MCT8316Z implements sensored trapezoidal control in a fixed-function state machine, so an external microcontroller is not required to spin the brushless-DC motor. The device integrates three analog hall comparators for position sensing to achieve sensored trapezoidal BLDC motor control. The control scheme is highly configurable through hardware pins or register settings ranging from motor current limiting behavior to fault response. The speed can be controlled through a PWM input.

There are a large number of protection features integrated into the MCT8316Z, intended to protect the device, motor, and system against fault events.

Refer [Application Information](#) for design consideration and recommendation on device usage.

Device Information⁽¹⁾

PART NUMBER	PACKAGE	BODY SIZE (NOM)
MCT8316ZR	VQFN (40)	7.00 mm × 5.00 mm
MCT8316ZT	VQFN (40)	7.00 mm × 5.00 mm

- (1) For all available packages, see the orderable addendum at the end of the data sheet.

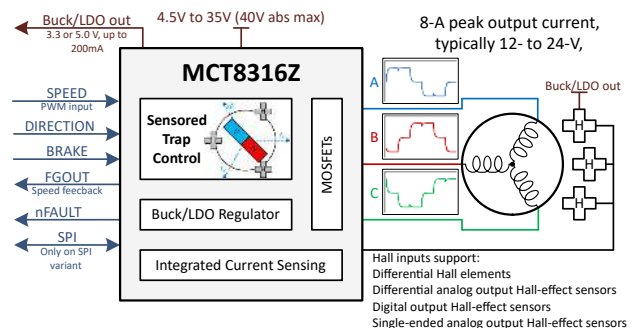

Simplified Schematic



Table of Contents

1 Features	1	8.3 Feature Description.....	21
2 Applications	1	8.4 Device Functional Modes.....	59
3 Description	1	8.5 SPI Communication.....	60
4 Revision History	2	8.6 Register Map.....	63
5 Device Comparison Table	3	9 Application and Implementation	78
6 Pin Configuration and Functions	4	9.1 Application Information.....	78
Pin Functions.....	5	9.2 Hall Sensor Configuration and Connection.....	79
7 Specifications	7	9.3 Typical Applications.....	83
7.1 Absolute Maximum Ratings.....	7	10 Power Supply Recommendations	88
7.2 ESD Ratings.....	7	10.1 Bulk Capacitance.....	88
7.3 Recommended Operating Conditions.....	7	11 Layout	89
7.4 Thermal Information.....	8	11.1 Layout Guidelines.....	89
7.5 Electrical Characteristics.....	8	11.2 Layout Example.....	90
7.6 SPI Timing Requirements.....	16	11.3 Thermal Considerations.....	91
7.7 SPI Secondary Mode Timings.....	17	12 Device and Documentation Support	92
7.8 Typical Characteristics.....	17	12.1 Support Resources.....	92
8 Detailed Description	18	12.2 Trademarks.....	92
8.1 Overview.....	18	12.3 Electrostatic Discharge Caution.....	92
8.2 Functional Block Diagram.....	19	12.4 Glossary.....	92

4 Revision History

Changes from Revision A (October 2021) to Revision B (November 2021) Page

- Updated MCT8316ZR from pre production to production status 1

Changes from Revision * (March 2021) to Revision A (October 2021) Page

- Updated Device Status to Production Data..... 1

5 Device Comparison Table

DEVICE	PACKAGES	INTERFACE	BUCK REGULATOR
MCT8316ZR	40-pin VQFN (7x5 mm)	SPI	Yes
MCT8316ZT		Hardware	

Table 5-1. MCT8316ZR (SPI variant) vs. MCT8316ZT (Hardware variant) configuration comparison

Parameters	MCT8316ZR (SPI variant)	MCT8316ZT (Hardware variant)
PWM control mode settings	PWM_MODE (4 settings)	MODE pin (7 settings)
Slew rate settings	SLEW (4 settings)	SLEW pin (4 settings)
Direction settings	DIR (2 settings)	DIR pin (2 settings)
DRVOFF pin configuration	DRV_OFF (2 settings)	Enabled
Current limit threshold	ILIMIT pin: AVDD/2 to AVDD/2-0.4V	ILIMIT pin: AVDD/2 to AVDD/2-0.4V
Current limit configuration	ILIM_RECIR (2 settings), PWM_100_DUTY_SEL	Recirculation fixed to Brake mode and PWM frequency for 100% duty fixed to 20 kHz
CSA GAIN	CSA_GAIN (4 settings)	Fixed to 0.15 V/A
Lead angle settings	ADVANCE_LVL (8 settings)	ADVANCE pin (7 settings)
Buck enable	BUCK_DIS (2 settings)	Enabled
Buck threshold	BUCK_SEL(4 settings)	VSEL_BK pin (4 settings)
Buck configuration: power sequencing, current limit and slew rate	BUCK_PS_DIS (2 settings) and BUCK_CL(2 settings)	Power sequencing enabled, current limit: 600 mA and slew rate: 1000 V/us
FGOUT configuration	FGOUT_SEL (4 settings)	Fixed to 3x commutation frequency
Motor lock configuration: mode, detection and retry timing	MTR_LOCK_MODE (4 settings), MTR_LOCK_TDET (4 settings), MTR_LOCK_RETRY (2 settings)	Enabled with latched shutdown mode and detection time of 1000 ms
Active demagnetization	EN_AAR (2 settings) and EN_ASR (2 settings)	MODE pin (7 settings)
OCP configuration: Mode,	OCP_MODE (4 settings) , OCP_LVL (4 settings) ,OCP_DEG (4 settings) and OCP_RETRY (2 settings)	Enabled with latched shutdown mode, level is fixed to 16A with 0.6 us deglitch time
Overvoltage protection configuration	OVP_EN (2 settings) , OVP_SEL (2 settings)	Enabled and level is fixed to 34V (typ)
Driver delay compensation configuration	DLYCMP_EN (2 settings), DLY_TARGET (16 settings)	Disabled
SDO pin configuration	SDO_MODE (2 settings)	NA
SPI fault configuration	SPI_PARITY(2 settings), SPI_SCLK_FLT(2 settings), SPI_ADDR_FLT(2 settings)	NA

6 Pin Configuration and Functions

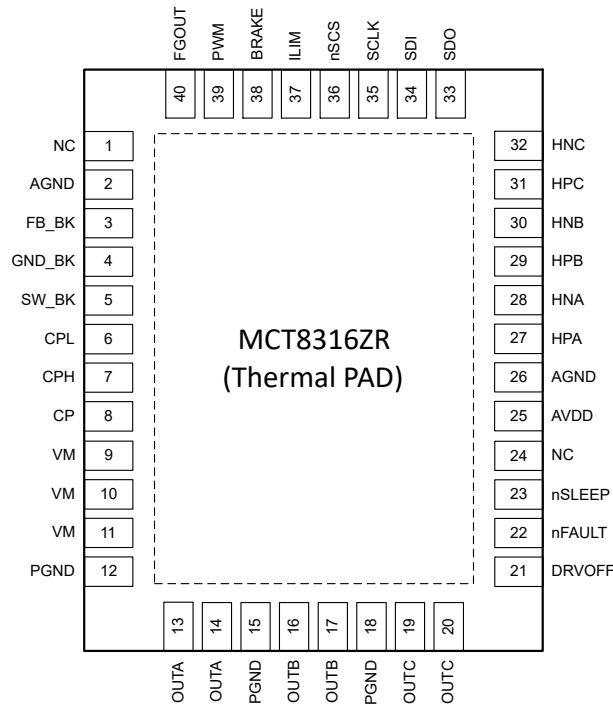

Figure 6-1. MCT8316ZR 40-Pin VQFN With Exposed Thermal Pad Top View

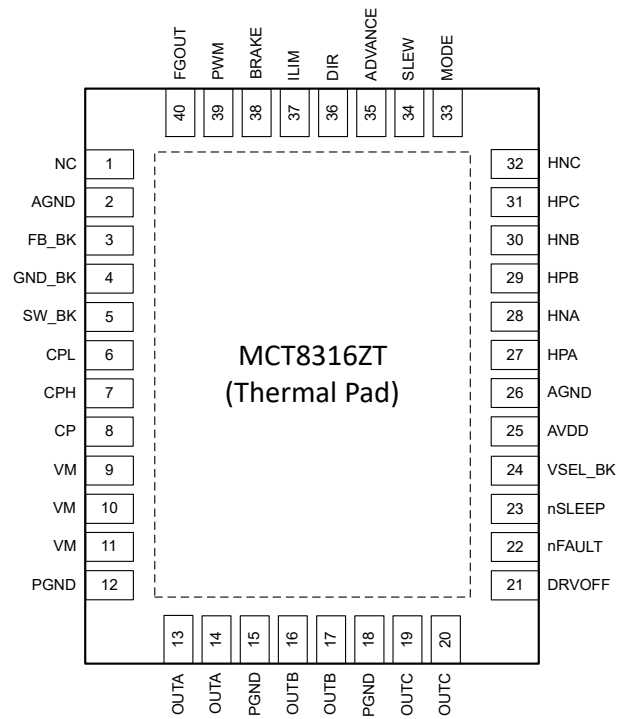

Figure 6-2. MCT8316ZT 40-Pin VQFN With Exposed Thermal Pad Top View

Pin Functions

PIN NAME	40-pin Package		TYPE ⁽¹⁾	DESCRIPTION
	MCT8316ZR	MCT8316ZT		
ADVANCE	—	35	I	Advance angle level setting. This pin is a 7-level input pin set by an external resistor.
AGND	2, 26	2, 26	GND	Device analog ground. Refer Layout Guidelines for connections recommendation.
AVDD	25	25	PWR O	3.3-V internal regulator output. Connect an X5R or X7R, 1- μ F, 6.3-V ceramic capacitor between the AVDD and AGND pins. This regulator can source up to 30 mA externally.
BRAKE	38	38	I	High \rightarrow Brake the motor when High by turning all low side MOSFETs ON Low \rightarrow normal operation
CP	8	8	PWR O	Charge pump output. Connect a X5R or X7R, 1- μ F, 16-V ceramic capacitor between the CP and VM pins.
CPH	7	7	PWR	Charge pump switching node. Connect a X5R or X7R, 47-nF, ceramic capacitor between the CPH and CPL pins. TI recommends a capacitor voltage rating at least twice the normal operating voltage of the device.
CPL	6	6	PWR	
DIR	—	36	I	Direction pin for setting the direction of the motor rotation to clockwise or counterclockwise.
DRVOFF	21	21	I	When this pin is pulled high the six MOSFETs in the power stage are turned OFF making all outputs Hi-Z.
FB_BK	3	3	PWR I	Feedback for buck regulator. Connect to buck regulator output after the inductor/resistor.
FGOUT	40	40	O	Motor Speed indicator output. Open-drain output requires an external pull-up resistor to 1.8V to 5.0V. It can be set to different division factor of Hall signals (see FGOUT Signal)
GND_BK	4	4	GND	Buck regulator ground. Refer Layout Guidelines for connections recommendation.
HPA	27	27	I	Phase A hall element positive input. Noise filter capacitors may be desirable, connected between the positive and negative hall inputs.
HPB	29	29	I	Phase B hall element positive input. Noise filter capacitors may be desirable, connected between the positive and negative hall inputs.
HPC	31	31	I	Phase C hall element positive input. Noise filter capacitors may be desirable, connected between the positive and negative hall inputs.
HNA	28	28	I	Phase A hall element negative input. Noise filter capacitors may be desirable, connected between the positive and negative hall inputs.
HNB	30	30	I	Phase B hall element negative input. Noise filter capacitors may be desirable, connected between the positive and negative hall inputs.
HNC	32	32	I	Phase C hall element negative input. Noise filter capacitors may be desirable, connected between the positive and negative hall inputs.
ILIM	37	37	I	Set the threshold for phase current used in cycle by cycle current limit.
MODE	—	33	I	PWM input mode setting. This pin is a 7-level input pin set by an external resistor.
NC	1, 24	1	—	No connection, open
nFAULT	22	22	O	Fault indicator. Pulled logic-low with fault condition; Open-drain output requires an external pull-up resistor to 1.8V to 5.0V. If external supply is used to pull up nFAULT, ensure that it is pulled to >2.2V on power up or the device will enter test mode
nSCS	36	—	I	Serial chip select. A logic low on this pin enables serial interface communication.
nSLEEP	23	23	I	Driver nSLEEP. When this pin is logic low, the device goes into a low-power sleep mode. An 20 to 40- μ s low pulse can be used to reset fault conditions without entering sleep mode.
OUTA	13, 14	13, 14	PWR O	Half bridge output A
OUTB	16, 17	16, 17	PWR O	Half bridge output B

MCT8316Z

SLVSF18B – MARCH 2021 – REVISED NOVEMBER 2021

PIN NAME	40-pin Package		TYPE ⁽¹⁾	DESCRIPTION
	MCT8316ZR	MCT8316ZT		
OUTC	19, 20	19, 20	PWR O	Half bridge output C
PGND	12, 15, 18	12, 15, 18	GND	Device power ground. Refer Layout Guidelines for connections recommendation.
PWM	39	39	I	PWM input for motor control. Set the duty cycle and switching frequency of the phase voltage of the motor.
SCLK	35	—	I	Serial clock input. Serial data is shifted out and captured on the corresponding rising and falling edge on this pin (SPI devices).
SDI	34	—	I	Serial data input. Data is captured on the falling edge of the SCLK pin (SPI devices).
SDO	33	—	O	Serial data output. Data is shifted out on the rising edge of the SCLK pin. This pin requires an external pullup resistor (SPI devices).
SLEW	—	34	I	Slew rate control setting. This pin is a 4-level input pin set by an external resistor (Hardware devices).
SW_BK	5	5	PWR O	Buck switch node. Connect this pin to an inductor or resistor.
VM	9, 10, 11	9, 10, 11	PWR I	Power supply. Connect to motor supply voltage; bypass to PGND with two 0.1- μ F capacitors (for each pin) plus one bulk capacitor rated for VM. TI recommends a capacitor voltage rating at least twice the normal operating voltage of the device.
VSEL_BK	—	24	I	Buck output voltage setting. This pin is a 4-level input pin set by an external resistor.
Thermal pad			GND	Must be connected to analog ground.

(1) I = input, O = output, GND = ground pin, PWR = power, NC = no connect

7 Specifications

7.1 Absolute Maximum Ratings

over operating ambient temperature range (unless otherwise noted)⁽¹⁾

	MIN	MAX	UNIT
Power supply pin voltage (VM)	-0.3	40	V
Power supply voltage ramp (VM)		4	V/μs
Voltage difference between ground pins (GND_BK, PGND, AGND)	-0.3	0.3	V
Charge pump voltage (CPH, CP)	-0.3	V _M + 6	V
Charge pump negative switching pin voltage (CPL)	-0.3	V _M + 0.3	V
Switching regulator pin voltage (FB_BK)	-0.3	5.75	V
Switching node pin voltage (SW_BK)	-0.3	V _M + 0.3	V
Analog regulators pin voltage (AVDD)	-0.3	4	V
Logic pin input voltage (DRVOFF, PWM, nSCS, nSLEEP, SCLK, SDI)	-0.3	5.75	V
Logic pin output voltage (nFAULT, SDO)	-0.3	5.75	V
Output pin voltage (OUTA, OUTB, OUTC)	-1	V _M + 1	V
Ambient temperature, T _A	-40	125	°C
Junction temperature, T _J	-40	150	°C
Storage temperature, T _{stg}	-65	150	°C

- (1) Operation outside the Absolute Maximum Ratings may cause permanent device damage. Absolute Maximum Ratings do not imply functional operation of the device at these or any other conditions beyond those listed under Recommended Operating Conditions. If used outside the Recommended Operating Conditions but within the Absolute Maximum Ratings, the device may not be fully functional, and this may affect device reliability, functionality, performance, and shorten the device lifetime.

7.2 ESD Ratings

			VALUE	UNIT
V _(ESD)	Electrostatic discharge	Human body model (HBM), per ANSI/ESDA/JEDEC JS-001 ⁽¹⁾	±2000	V
		Charged device model (CDM), per ANSI/ESDA/JEDEC JS-002 ⁽²⁾	±500	

- (1) JEDEC document JEP155 states that 500-V HBM allows safe manufacturing with a standard ESD control process.
(2) JEDEC document JEP157 states that 250-V CDM allows safe manufacturing with a standard ESD control process.

7.3 Recommended Operating Conditions

over operating ambient temperature range (unless otherwise noted)

			MIN	NOM	MAX	UNIT
V _{VM}	Power supply voltage	V _{VM}	4.5	24	35	V
f _{PWM}	Output PWM frequency	OUTA, OUTB, OUTC			200	kHz
I _{OUT} ⁽¹⁾	Peak output winding current	OUTA, OUTB, OUTC			8	A
V _{IN}	Logic input voltage	DRVOFF, INHx, INLx, nSCS, nSLEEP, SCLK, SDI	-0.1		5.5	V
V _{OD}	Open drain pullup voltage	nFAULT, SDO	-0.1		5.5	V
V _{SDO}	Push-pull voltage	SDO	2.2		5.5	V
I _{OD}	Open drain output current	nFAULT, SDO			5	mA
V _{VREF}	Voltage reference pin voltage	VREF	2.8		AVDD	V
T _A	Operating ambient temperature		-40		125	°C
T _J	Operating Junction temperature		-40		150	°C

- (1) Power dissipation and thermal limits must be observed

7.4 Thermal Information

THERMAL METRIC ⁽¹⁾		MCT8316ZT, MCT8316ZR	UNIT
		VQFN (RGF)	
		40 Pins	
R _{θJA}	Junction-to-ambient thermal resistance	25.7	°C/W
R _{θJC(top)}	Junction-to-case (top) thermal resistance	15.2	°C/W
R _{θJB}	Junction-to-board thermal resistance	7.3	°C/W
Ψ _{JT}	Junction-to-top characterization parameter	0.2	°C/W
Ψ _{JB}	Junction-to-board characterization parameter	7.2	°C/W
R _{θJC(bot)}	Junction-to-case (bottom) thermal resistance	2.0	°C/W

(1) For more information about traditional and new thermal metrics, see the [Semiconductor and IC Package Thermal Metrics](#) application report.

7.5 Electrical Characteristics

T_J = –40°C to +150°C, V_{VM} = 4.5 to 35 V (unless otherwise noted). Typical limits apply for T_A = 25°C, V_{VM} = 24 V

PARAMETER		TEST CONDITIONS	MIN	TYP	MAX	UNIT
POWER SUPPLIES						
I _{VMQ}	VM sleep mode current	V _{VM} > 6 V, nSLEEP = 0, T _A = 25 °C		1.5	2.5	μA
		nSLEEP = 0		2.5	5	μA
I _{VMS}	VM standby mode current (Buck regulator disabled)	nSLEEP = 1, PWM = 0, SPI = 'OFF', BUCK_DIS = 1;		4	10	mA
		V _{VM} > 6 V, nSLEEP = 1, PWM = 0, SPI = 'OFF', T _A = 25 °C, BUCK_DIS = 1;		4	5	mA
I _{VMS}	VM standby mode current (Buck regulator enabled)	V _{VM} > 6 V, nSLEEP = 1, PWM = 0, SPI = 'OFF', I _{BK} = 0, T _A = 25 °C, BUCK_DIS = 0;		5	6	mA
		nSLEEP = 1, PWM = 0, SPI = 'OFF', I _{BK} = 0, BUCK_DIS = 0;		6	10	mA
I _{VM}	VM operating mode current (Buck regulator disabled)	V _{VM} > 6 V, nSLEEP = 1, f _{PWM} = 25 kHz, T _A = 25 °C, BUCK_DIS = 1		10	13	mA
		V _{VM} > 6 V, nSLEEP = 1, f _{PWM} = 200 kHz, T _A = 25 °C, BUCK_DIS = 1		18	21	mA
		nSLEEP = 1, f _{PWM} = 25 kHz, BUCK_DIS = 1		11	15	mA
		nSLEEP = 1, f _{PWM} = 200 kHz, BUCK_DIS = 1		17	24	mA
I _{VM}	VM operating mode current (Buck regulator enabled)	V _{VM} > 6 V, nSLEEP = 1, f _{PWM} = 25 kHz, T _A = 25 °C, BUCK_DIS = 0; BUCK_PS_DIS = 0		11	13	mA
		V _{VM} > 6 V, nSLEEP = 1, f _{PWM} = 200 kHz, T _A = 25 °C, BUCK_DIS = 0; BUCK_PS_DIS = 0		19	22	mA
		nSLEEP = 1, f _{PWM} = 25 kHz, BUCK_DIS = 0; BUCK_PS_DIS = 0		12	16	mA
		nSLEEP = 1, f _{PWM} = 200 kHz, BUCK_DIS = 0; BUCK_PS_DIS = 0		18	27	mA
V _{AVDD}	Analog regulator voltage	0 mA ≤ I _{AVDD} ≤ 30 mA; BUCK_PS_DIS = 0	3.1	3.3	3.465	V
I _{AVDD}	External analog regulator load				30	mA
V _{VCP}	Charge pump regulator voltage	VCP with respect to VM	3.6	4.7	5.2	V
f _{CP}	Charge pump switching frequency			400		kHz

$T_J = -40^{\circ}\text{C}$ to $+150^{\circ}\text{C}$, $V_{VM} = 4.5$ to 35 V (unless otherwise noted). Typical limits apply for $T_A = 25^{\circ}\text{C}$, $V_{VM} = 24\text{ V}$

PARAMETER		TEST CONDITIONS	MIN	TYP	MAX	UNIT
$t_{\text{PWM_LOW}}$	PWM low time required for motor lock detection			200		ms
t_{WAKE}	Wakeup time	$V_{VM} > V_{UVLO}$, nSLEEP = 1 to outputs ready and nFAULT released			1	ms
t_{SLEEP}	Sleep Pulse time	nSLEEP = 0 period to enter sleep mode	120			μs
t_{RST}	Reset Pulse time	nSLEEP = 0 period to reset faults	20		40	μs
BUCK REGULATOR						
V_{BK}	Buck regulator average voltage ($L_{\text{BK}} = 47\ \mu\text{H}$, $C_{\text{BK}} = 22\ \mu\text{F}$) (SPI Device)	$V_{VM} > 6\text{ V}$, $0\text{ mA} \leq I_{\text{BK}} \leq 200\text{ mA}$, BUCK_SEL = 00b	3.1	3.3	3.5	V
		$V_{VM} > 6\text{ V}$, $0\text{ mA} \leq I_{\text{BK}} \leq 200\text{ mA}$, BUCK_SEL = 01b	4.6	5.0	5.4	V
		$V_{VM} > 6\text{ V}$, $0\text{ mA} \leq I_{\text{BK}} \leq 200\text{ mA}$, BUCK_SEL = 10b	3.7	4.0	4.3	V
		$V_{VM} > 6.7\text{ V}$, $0\text{ mA} \leq I_{\text{BK}} \leq 200\text{ mA}$, BUCK_SEL = 11b	5.2	5.7	6.2	V
		$V_{VM} < 6.0\text{ V}$ (BUCK_SEL = 00b, 01b, 10b) or $V_{VM} < 6.0\text{ V}$ (BUCK_SEL = 11b), $0\text{ mA} \leq I_{\text{BK}} \leq 200\text{ mA}$		$V_{VM} - I_{\text{BK}} * (R_{\text{LBK}} + 2)$ ⁽¹⁾		V
V_{BK}	Buck regulator average voltage ($L_{\text{BK}} = 22\ \mu\text{H}$, $C_{\text{BK}} = 22\ \mu\text{F}$) (SPI Device)	$V_{VM} > 6\text{ V}$, $0\text{ mA} \leq I_{\text{BK}} \leq 50\text{ mA}$, BUCK_SEL = 00b	3.1	3.3	3.5	V
		$V_{VM} > 6\text{ V}$, $0\text{ mA} \leq I_{\text{BK}} \leq 50\text{ mA}$, BUCK_SEL = 01b	4.6	5.0	5.4	V
		$V_{VM} > 6\text{ V}$, $0\text{ mA} \leq I_{\text{BK}} \leq 50\text{ mA}$, BUCK_SEL = 10b	3.7	4.0	4.3	V
		$V_{VM} > 6.7\text{ V}$, $0\text{ mA} \leq I_{\text{BK}} \leq 50\text{ mA}$, BUCK_SEL = 11b	5.2	5.7	6.2	V
		$V_{VM} < 6.0\text{ V}$ (BUCK_SEL = 00b, 01b, 10b) or $V_{VM} < 6.0\text{ V}$ (BUCK_SEL = 11b), $0\text{ mA} \leq I_{\text{BK}} \leq 50\text{ mA}$		$V_{VM} - I_{\text{BK}} * (R_{\text{LBK}} + 2)$ ⁽¹⁾		V
V_{BK}	Buck regulator average voltage ($R_{\text{BK}} = 22\ \Omega$, $C_{\text{BK}} = 22\ \mu\text{F}$) (SPI Device)	$V_{VM} > 6\text{ V}$, $0\text{ mA} \leq I_{\text{BK}} \leq 40\text{ mA}$, BUCK_SEL = 00b	3.1	3.3	3.5	V
		$V_{VM} > 6\text{ V}$, $0\text{ mA} \leq I_{\text{BK}} \leq 40\text{ mA}$, BUCK_SEL = 01b	4.6	5.0	5.4	V
		$V_{VM} > 6\text{ V}$, $0\text{ mA} \leq I_{\text{BK}} \leq 40\text{ mA}$, BUCK_SEL = 10b	3.7	4.0	4.3	V
		$V_{VM} > 6.7\text{ V}$, $0\text{ mA} \leq I_{\text{BK}} \leq 40\text{ mA}$, BUCK_SEL = 11b	5.2	5.7	6.2	V
		$V_{VM} < 6.0\text{ V}$ (BUCK_SEL = 00b, 01b, 10b) or $V_{VM} < 6.0\text{ V}$ (BUCK_SEL = 11b), $0\text{ mA} \leq I_{\text{BK}} \leq 40\text{ mA}$		$V_{VM} - I_{\text{BK}} * (R_{\text{BK}} + 2)$ ⁽¹⁾		V
V_{BK}	Buck regulator average voltage ($L_{\text{BK}} = 47\ \mu\text{H}$, $C_{\text{BK}} = 22\ \mu\text{F}$) (HW Device)	$V_{VM} > 6\text{ V}$, $0\text{ mA} \leq I_{\text{BK}} \leq 200\text{ mA}$, VSEL_BK pin tied to AGND	3.1	3.3	3.5	V
		$V_{VM} > 6\text{ V}$, $0\text{ mA} \leq I_{\text{BK}} \leq 200\text{ mA}$, VSEL_BK pin to Hi-Z	4.6	5.0	5.4	
		$V_{VM} > 6\text{ V}$, $0\text{ mA} \leq I_{\text{BK}} \leq 200\text{ mA}$, VSEL_BK pin to $47\text{ k}\Omega$ +/- 5% tied to AVDD	3.7	4.0	4.3	
		$V_{VM} > 6.7\text{ V}$, $0\text{ mA} \leq I_{\text{BK}} \leq 200\text{ mA}$, VSEL_BK pin tied to AVDD	5.2	5.7	6.2	
		$V_{VM} < 6.0\text{ V}$, $0\text{ mA} \leq I_{\text{BK}} \leq 200\text{ mA}$		$V_{VM} - I_{\text{BK}} * (R_{\text{LBK}} + 2)$ ⁽¹⁾		V

MCT8316Z

SLVSF18B – MARCH 2021 – REVISED NOVEMBER 2021

 $T_J = -40^{\circ}\text{C to } +150^{\circ}\text{C}$, $V_{VM} = 4.5 \text{ to } 35 \text{ V}$ (unless otherwise noted). Typical limits apply for $T_A = 25^{\circ}\text{C}$, $V_{VM} = 24 \text{ V}$

PARAMETER		TEST CONDITIONS	MIN	TYP	MAX	UNIT
V_{BK}	Buck regulator average voltage ($L_{BK} = 22 \mu\text{H}$, $C_{BK} = 22 \mu\text{F}$) (HW Device)	$V_{VM} > 6 \text{ V}$, $0 \text{ mA} \leq I_{BK} \leq 50 \text{ mA}$, VSEL_BK pin tied to AGND	3.1	3.3	3.5	V
		$V_{VM} > 6 \text{ V}$, $0 \text{ mA} \leq I_{BK} \leq 50 \text{ mA}$, VSEL_BK pin to Hi-Z	4.6	5.0	5.4	V
		$V_{VM} > 6 \text{ V}$, $0 \text{ mA} \leq I_{BK} \leq 50 \text{ mA}$, VSEL_BK pin to $47 \text{ k}\Omega$ +/- 5% tied to AVDD	3.7	4.0	4.3	V
		$V_{VM} > 6.7 \text{ V}$, $0 \text{ mA} \leq I_{BK} \leq 50 \text{ mA}$, VSEL_BK pin tied to AVDD	5.2	5.7	6.2	V
		$V_{VM} < 6.0 \text{ V}$, $0 \text{ mA} \leq I_{BK} \leq 50 \text{ mA}$		V_{VM}^- $I_{BK}^*(R_{LBK}+2)$ ⁽¹⁾		V
V_{BK}	Buck regulator average voltage ($R_{BK} = 22 \Omega$, $C_{BK} = 22 \mu\text{F}$) (HW Device)	$V_{VM} > 6 \text{ V}$, $0 \text{ mA} \leq I_{BK} \leq 40 \text{ mA}$, VSEL_BK pin tied to AGND	3.1	3.3	3.5	V
		$V_{VM} > 6 \text{ V}$, $0 \text{ mA} \leq I_{BK} \leq 40 \text{ mA}$, VSEL_BK pin to Hi-Z	4.6	5.0	5.4	V
		$V_{VM} > 6 \text{ V}$, $0 \text{ mA} \leq I_{BK} \leq 40 \text{ mA}$, VSEL_BK pin to $47 \text{ k}\Omega$ +/- 5% tied to AVDD	3.7	4.0	4.3	V
		$V_{VM} > 6.7 \text{ V}$, $0 \text{ mA} \leq I_{BK} \leq 40 \text{ mA}$, VSEL_BK pin tied to AVDD	5.2	5.7	6.2	V
		$V_{VM} < 6.0 \text{ V}$, $0 \text{ mA} \leq I_{BK} \leq 40 \text{ mA}$		V_{VM}^- $I_{BK}^*(R_{BK}+2)$ ⁽¹⁾		V
V_{BK_RIP}	Buck regulator ripple voltage	$V_{VM} > 6 \text{ V}$, $0 \text{ mA} \leq I_{BK} \leq 200 \text{ mA}$, Buck regulator with inductor, $L_{BK} = 47 \mu\text{H}$, C_{BK} $= 22 \mu\text{F}$	-100		100	mV
		$V_{VM} > 6 \text{ V}$, $0 \text{ mA} \leq I_{BK} \leq 50 \text{ mA}$, Buck regulator with inductor, $L_{BK} = 22 \mu\text{H}$, C_{BK} $= 22 \mu\text{F}$	-100		100	mV
		$V_{VM} > 6 \text{ V}$, $0 \text{ mA} \leq I_{BK} \leq 50 \text{ mA}$, Buck regulator with resistor; $R_{BK} = 22 \Omega$, C_{BK} $= 22 \mu\text{F}$	-100		100	mV
I_{BK}	External buck regulator load	$L_{BK} = 47 \mu\text{H}$, $C_{BK} = 22 \mu\text{F}$, BUCK_PS_DIS = 1b			200	mA
		$L_{BK} = 47 \mu\text{H}$, $C_{BK} = 22 \mu\text{F}$, BUCK_PS_DIS = 0b			200 – I_{AVDD}	mA
		$L_{BK} = 22 \mu\text{H}$, $C_{BK} =$ $22 \mu\text{F}$, BUCK_PS_DIS = 1b			50	mA
		$L_{BK} = 22 \mu\text{H}$, $C_{BK} = 22 \mu\text{F}$, BUCK_PS_DIS = 0b			50 – I_{AVDD}	mA
		$R_{BK} = 22 \Omega$, $C_{BK} =$ $22 \mu\text{F}$, BUCK_PS_DIS = 1b			40	mA
		$R_{BK} = 22 \Omega$, $C_{BK} = 22 \mu\text{F}$, BUCK_PS_DIS = 0b			40 – I_{AVDD}	mA
f_{SW_BK}	Buck regulator switching frequency	Regulation Mode	20		535	kHz
		Linear Mode	20		535	kHz

$T_J = -40^{\circ}\text{C}$ to $+150^{\circ}\text{C}$, $V_{VM} = 4.5$ to 35 V (unless otherwise noted). Typical limits apply for $T_A = 25^{\circ}\text{C}$, $V_{VM} = 24$ V

PARAMETER		TEST CONDITIONS	MIN	TYP	MAX	UNIT
V_{BK_UV}	Buck regulator undervoltage lockout (SPI Device)	V_{BK} rising, BUCK_SEL = 00b	2.7	2.8	2.9	V
		V_{BK} falling, BUCK_SEL = 00b	2.5	2.6	2.7	V
		V_{BK} rising, BUCK_SEL = 01b	4.2	4.4	4.55	V
		V_{BK} falling, BUCK_SEL = 01b	4.0	4.2	4.35	V
		V_{BK} rising, BUCK_SEL = 10b	2.7	2.8	2.9	V
		V_{BK} falling, BUCK_SEL = 10b	2.5	2.6	2.7	V
		V_{BK} rising, BUCK_SEL = 11b	4.2	4.4	4.55	V
		V_{BK} falling, BUCK_SEL = 11b	4	4.2	4.35	V
V_{BK_UV}	Buck regulator undervoltage lockout (HW Device)	V_{BK} rising, VSEL_BK pin tied to AGND	2.7	2.8	2.9	V
		V_{BK} falling, VSEL_BK pin tied to AGND	2.5	2.6	2.7	V
		V_{BK} rising, VSEL_BK pin to 47 k Ω +/- 5% tied to AVDD	4.3	4.4	4.5	V
		V_{BK} falling, VSEL_BK pin to 47 k Ω +/- 5% tied to AVDD	4.1	4.2	4.3	V
		V_{BK} rising, VSEL_BK pin to Hi-Z	2.7	2.8	2.9	V
		V_{BK} falling, VSEL_BK pin to Hi-Z	2.5	2.6	2.7	V
		V_{BK} rising, VSEL_BK pin tied to AVDD	4.2	4.4	4.55	V
		V_{BK} falling, VSEL_BK pin tied to AVDD	4.0	4.2	4.35	V
$V_{BK_UV_HYS}$	Buck regulator undervoltage lockout hysteresis	Rising to falling threshold	90	200	320	mV
I_{BK_CL}	Buck regulator Current limit threshold (SPI Device)	BUCK_CL = 0b	360	600	900	mA
		BUCK_CL = 1b	80	150	250	mA
I_{BK_CL}	Buck regulator Current limit threshold (HW Device)		360	600	900	mA
I_{BK_OCP}	Buck regulator Overcurrent protection trip point		2	3	4	A
t_{BK_RETRY}	Overcurrent protection retry time		0.7	1	1.3	ms
LOGIC-LEVEL INPUTS (BRAKE, DIR, DRVOFF, nSLEEP, PWM, SCLK, SDI)						
V_{IL}	Input logic low voltage		0		0.6	V
V_{IH}	Input logic high voltage	Other Pins	1.5		5.5	V
		nSLEEP	1.6		5.5	V
V_{HYS}	Input logic hysteresis	Other Pins	180	300	420	mV
		nSLEEP	95	250	420	mV
I_{IL}	Input logic low current	V_{PIN} (Pin Voltage) = 0 V	-1		1	μ A
I_{IH}	Input logic high current	nSLEEP, V_{PIN} (Pin Voltage) = 5 V	10		30	μ A
		Other pins, V_{PIN} (Pin Voltage) = 5 V	30		75	μ A
R_{PD}	Input pulldown resistance	nSLEEP	150	200	300	k Ω
		Other pins	70	100	130	k Ω
C_{ID}	Input capacitance			30		pF
LOGIC-LEVEL INPUTS (nSCS)						
V_{IL}	Input logic low voltage		0		0.6	V
V_{IH}	Input logic high voltage		1.5		5.5	V
V_{HYS}	Input logic hysteresis		180	300	420	mV
I_{IL}	Input logic low current	V_{PIN} (Pin Voltage) = 0 V			75	μ A
I_{IH}	Input logic high current	V_{PIN} (Pin Voltage) = 5 V	-1		25	μ A
R_{PU}	Input pullup resistance		80	100	130	k Ω
C_{ID}	Input capacitance			30		pF

MCT8316Z

SLVSF18B – MARCH 2021 – REVISED NOVEMBER 2021

 $T_J = -40^{\circ}\text{C}$ to $+150^{\circ}\text{C}$, $V_{VM} = 4.5$ to 35 V (unless otherwise noted). Typical limits apply for $T_A = 25^{\circ}\text{C}$, $V_{VM} = 24\text{ V}$

PARAMETER		TEST CONDITIONS	MIN	TYP	MAX	UNIT
FOUR-LEVEL INPUTS (SLEW, VSEL_BK)						
V_{L1}	Input mode 1 voltage	Tied to AGND	0		$0.2 \cdot \frac{AVD}{D}$	V
V_{L2}	Input mode 2 voltage	Hi-Z	$0.27 \cdot \frac{AV}{DD}$	$0.5 \cdot AVDD$	$0.545 \cdot \frac{AV}{DD}$	V
V_{L3}	Input mode 3 voltage	47 k Ω +/- 5% tied to AVDD	$0.606 \cdot \frac{AV}{DD}$	$0.757 \cdot \frac{AVD}{D}$	$0.909 \cdot \frac{AV}{DD}$	V
V_{L4}	Input mode 4 voltage	Tied to AVDD	$0.945 \cdot \frac{AV}{DD}$		AVDD	V
R_{PU}	Input pullup resistance	To AVDD	70	100	130	k Ω
R_{PD}	Input pulldown resistance	To AGND	70	100	130	k Ω
FOUR-LEVEL INPUTS (OCP/SR)						
V_{L1}	Input mode 1 voltage	Tied to AGND	0		$0.09 \cdot \frac{AV}{DD}$	V
V_{L2}	Input mode 2 voltage	22 k Ω \pm 5% to AGND	$0.12 \cdot \frac{AV}{DD}$	$0.15 \cdot AVDD$	$0.2 \cdot \frac{AVD}{D}$	V
V_{L3}	Input mode 3 voltage	100 k Ω \pm 5% to AGND	$0.27 \cdot \frac{AV}{DD}$	$0.33 \cdot AVDD$	$0.4 \cdot \frac{AVD}{D}$	V
V_{L4}	Input mode 4 voltage	Hi-Z	$0.45 \cdot \frac{AV}{DD}$	$0.5 \cdot AVDD$	$0.55 \cdot \frac{AV}{DD}$	V
V_{L5}	Input mode 5 voltage	100 k Ω \pm 5% to AVDD	$0.6 \cdot \frac{AVD}{D}$	$0.66 \cdot AVDD$	$0.73 \cdot \frac{AV}{DD}$	V
V_{L6}	Input mode 6 voltage	22 k Ω \pm 5% to AVDD	$0.77 \cdot \frac{AV}{DD}$	$0.85 \cdot AVDD$	$0.9 \cdot \frac{AVD}{D}$	V
V_{L7}	Input mode 7 voltage	Tied to AVDD	$0.94 \cdot \frac{AV}{DD}$		AVDD	V
R_{PU}	Input pullup resistance	To AVDD	80	100	120	k Ω
R_{PD}	Input pulldown resistance	To AGND	80	100	120	k Ω
OPEN-DRAIN OUTPUTS (FGOUT, nFAULT)						
V_{OL}	Output logic low voltage	$I_{OD} = 5\text{ mA}$			0.4	V
I_{OH}	Output logic high current	$V_{OD} = 5\text{ V}$	-1		1	μA
C_{OD}	Output capacitance				30	pF
PUSH-PULL OUTPUTS (SDO)						
V_{OL}	Output logic low voltage	$I_{OP} = 5\text{ mA}$	0		0.4	V
V_{OH}	Output logic high voltage	$I_{OP} = 5\text{ mA}$	2.2		5.5	V
I_{OL}	Output logic low leakage current	$V_{OP} = 0\text{ V}$	-1		1	μA
I_{OH}	Output logic high leakage current	$V_{OP} = 5\text{ V}$	-1		1	μA
C_{OD}	Output capacitance				30	pF
DRIVER OUTPUTS						
$R_{DS(ON)}$	Total MOSFET on resistance (High-side + Low-side)	$V_{VM} > 6\text{ V}$, $I_{OUT} = 1\text{ A}$, $T_A = 25^{\circ}\text{C}$		95	120	m Ω
		$V_{VM} < 6\text{ V}$, $I_{OUT} = 1\text{ A}$, $T_A = 25^{\circ}\text{C}$		105	130	m Ω
		$V_{VM} > 6\text{ V}$, $I_{OUT} = 1\text{ A}$, $T_J = 150^{\circ}\text{C}$		140	185	m Ω
		$V_{VM} < 6\text{ V}$, $I_{OUT} = 1\text{ A}$, $T_J = 150^{\circ}\text{C}$		145	190	m Ω

$T_J = -40^{\circ}\text{C}$ to $+150^{\circ}\text{C}$, $V_{VM} = 4.5$ to 35 V (unless otherwise noted). Typical limits apply for $T_A = 25^{\circ}\text{C}$, $V_{VM} = 24$ V

PARAMETER		TEST CONDITIONS	MIN	TYP	MAX	UNIT
SR	Phase pin slew rate switching low to high (Rising from 20 % to 80 %)	$V_{VM} = 24$ V, SLEW = 00b or SLEW pin tied to AGND	14	25	45	V/us
		$V_{VM} = 24$ V, SLEW = 01b or SLEW pin to Hi-Z	30	50	80	V/us
		$V_{VM} = 24$ V, SLEW = 10b or SLEW pin to 47 k Ω +/- 5% to AVDD	80	125	185	V/us
		$V_{VM} = 24$ V, SLEW = 11b or SLEW pin tied to AVDD	130	200	280	V/us
SR	Phase pin slew rate switching high to low (Falling from 80 % to 20 %)	$V_{VM} = 24$ V, SLEW = 00b or SLEW pin tied to AGND	14	25	45	V/us
		$V_{VM} = 24$ V, SLEW = 01b or SLEW pin to Hi-Z	30	50	80	V/us
		$V_{VM} = 24$ V, SLEW = 10b or SLEW pin to 47 k Ω +/- 5% to AVDD	80	125	185	V/us
		$V_{VM} = 24$ V, SLEW = 11b or SLEW pin tied to AVDD	110	200	280	V/us
I_{LEAK}	Leakage current on OUTx	$V_{OUTx} = V_{VM}$, nSLEEP = 1			5	mA
	Leakage current on OUTx	$V_{OUTx} = 0$ V, nSLEEP = 1			1	μ A
t_{DEAD}	Output dead time (high to low / low to high)	$V_{VM} = 24$ V, SR = 25 V/ μ s, HS driver ON to LS driver OFF		1800	3400	ns
		$V_{VM} = 24$ V, SR = 50 V/ μ s, HS driver ON to LS driver OFF		1100	1550	ns
		$V_{VM} = 24$ V, SR = 125 V/ μ s, HS driver ON to LS driver OFF		650	1000	ns
		$V_{VM} = 24$ V, SR = 200 V/ μ s, HS driver ON to LS driver OFF		500	750	ns
t_{PD}	Propagation delay (high-side / low-side ON/OFF)	$V_{VM} = 24$ V, PWM = 1 to OUTx transision, SR = 25 V/ μ s		2000	4550	ns
		$V_{VM} = 24$ V, PWM = 1 to OUTx transision, SR = 50V/ μ s		1200	2150	ns
		$V_{VM} = 24$ V, PWM = 1 to OUTx transision, SR = 125 V/ μ s		800	1350	ns
		$V_{VM} = 24$ V, PWM = 1 to OUTx transision, SR = 200 V/ μ s		650	1050	ns
t_{MIN_PULSE}	Minimum output pulse width	SR = 200 V/ μ s	600			ns
CURRENT SENSE AMPLIFIER						
G_{CSA}	Current sense gain (SPI Device)	CSA_GAIN = 00		0.15		V/A
		CSA_GAIN = 01		0.3		V/A
		CSA_GAIN = 10		0.6		V/A
		CSA_GAIN = 11		1.2		V/A
G_{CSA}	Current sense gain (HW Device)	GAIN pin tied to AGND		0.15		V/A
		GAIN pin to Hi-Z		0.3		V/A
		GAIN pin to 47 k Ω \pm 5% to AVDD		0.6		V/A
		GAIN pin tied to AVDD		1.2		V/A
G_{CSA_ERR}	Current sense gain error	$T_A = 25^{\circ}\text{C}$, $I_{PHASE} < 4$ A	-2		2	%
		$T_A = 25^{\circ}\text{C}$, $I_{PHASE} > 4$ A	-3		3	%
		$I_{PHASE} < 4$ A	-3		3	%
		$I_{PHASE} > 4$ A	-5		5	%
I_{MATCH}	Current sense gain error matching between phases A, B and C	$T_A = 25^{\circ}\text{C}$	-3		3	%
			-5		5	%

MCT8316Z

SLVSF18B – MARCH 2021 – REVISED NOVEMBER 2021

 $T_J = -40^{\circ}\text{C}$ to $+150^{\circ}\text{C}$, $V_{VM} = 4.5$ to 35 V (unless otherwise noted). Typical limits apply for $T_A = 25^{\circ}\text{C}$, $V_{VM} = 24\text{ V}$

PARAMETER		TEST CONDITIONS	MIN	TYP	MAX	UNIT
FS _{POS}	Full scale positive current measurement		8			A
FS _{NEG}	Full scale negative current measurement				-8	A
V _{LINEAR}	SOX output voltage linear range		0.25	$V_{VREF} - 0.25$		V
I _{OFFSET}	Current sense offset low side current in	Phase current = 0 A, G _{CSA} = 0.15 V/A	-50		50	mA
		Phase current = 0 A, G _{CSA} = 0.3 V/A	-50		50	mA
		Phase current = 0 A, G _{CSA} = 0.6 V/A	-50		50	mA
		Phase current = 0 A, G _{CSA} = 1.2 V/A	-50		50	mA
t _{SET}	Settling time to $\pm 1\%$, 30 pF	Step on SOX = 1.2 V, G _{CSA} = 0.15 V/A			1	μs
		Step on SOX = 1.2 V, G _{CSA} = 0.3 V/A			1	μs
		Step on SOX = 1.2 V, G _{CSA} = 0.6 V/A			1	μs
		Step on SOX = 1.2 V, G _{CSA} = 1.2 V/A			1	μs
V _{DRIFT}	Drift offset	Phase current = 0 A	-160		160	$\mu\text{A}/^{\circ}\text{C}$
I _{VREF}	VREF input current	VREF = 3.0 V			50	μA
PSRR	Power Supply Rejection Ratio	AVDD to SOx, DC	55		80	dB
		AVDD to SOx, 10 kHz	39		56	dB
		AVDD to SOx, 500 kHz	5		22	dB
HALL COMPARATORS						
V _{ICM}	Input Common Mode Voltage (Hall)		0.5		AVDD - 1.2	V
V _{HYS}	Voltage hysteresis (SPI Device)	HALL_HYS = 0	1.5	5	8	mV
		HALL_HYS = 1	35	50	75	mV
	Voltage hysteresis (HW Device)		1.5	5	8	mV
ΔV_{HYS}	Hall comparator hysteresis difference	Between Hall A, Hall B and Hall C comparator	-8		8	mV
V _{H(MIN)}	Minimum Hall Differential Voltage		40			mV
I _I	Input leakage current	HPX = HNX = 0 V	-1		1	μA
t _{HDG}	Hall deglitch time		0.7	1.15	1.7	μs
t _{HEDG}	Hall Enable deglitch time	During Power up		1.4		μs
PULSE-BY-PULSE CURRENT LIMIT						
V _{LIM}	Voltage on VLIM pin for cycle by cycle current limit		AVDD/2		AVDD/2 - 0.4	V
I _{LIMIT}	Current limit corresponding to VLIM pin voltage range		0		8	A
I _{LIM_AC}	Current limit accuracy		-10		10	%
t _{BLANK}	Cycle by cycle current limit blank time			5		μs
ADVANCE ANGLE						
θ_{ADV}	Advance Angle Setting (SPI Device)	ADVANCE_LVL = 000 b		0		$^{\circ}$
		ADVANCE_LVL = 001 b		4		$^{\circ}$
		ADVANCE_LVL = 010 b		7		$^{\circ}$
		ADVANCE_LVL = 011 b		11		$^{\circ}$
		ADVANCE_LVL = 100 b		15		$^{\circ}$
		ADVANCE_LVL = 101 b		20		$^{\circ}$
		ADVANCE_LVL = 110 b		25		$^{\circ}$
		ADVANCE_LVL = 111 b		30		$^{\circ}$

$T_J = -40^{\circ}\text{C}$ to $+150^{\circ}\text{C}$, $V_{VM} = 4.5$ to 35 V (unless otherwise noted). Typical limits apply for $T_A = 25^{\circ}\text{C}$, $V_{VM} = 24$ V

PARAMETER		TEST CONDITIONS	MIN	TYP	MAX	UNIT
θ_{ADV}	Advance Angle Setting (HW Device)	Advance pin tied to AGND		0		$^{\circ}$
		Advance pin tied to $22\text{ k}\Omega \pm 5\%$ to AGND		4		$^{\circ}$
		Advance pin tied to $100\text{ k}\Omega \pm 5\%$ to AGND		11		$^{\circ}$
		Advance pin tied to Hi-Z		15		$^{\circ}$
		Advance pin tied to $100\text{ k}\Omega \pm 5\%$ to AVDD		20		$^{\circ}$
		Advance pin tied to $22\text{ k}\Omega \pm 5\%$ to AVDD		25		$^{\circ}$
		Advance pin tied to Tied to AVDD		30		$^{\circ}$
PROTECTION CIRCUITS						
V_{UVLO}	Supply undervoltage lockout (UVLO)	VM rising	4.3	4.4	4.5	V
		VM falling	4.1	4.2	4.3	V
V_{UVLO_HYS}	Supply undervoltage lockout hysteresis	Rising to falling threshold	140	200	350	mV
t_{UVLO}	Supply undervoltage deglitch time		3	5	7	μs
V_{OVP}	Supply overvoltage protection (OVP) (SPI Device)	Supply rising, OVP_EN = 1, OVP_SEL = 0	32.5	34	35	V
		Supply falling, OVP_EN = 1, OVP_SEL = 0	31.8	33	34.3	V
		Supply rising, OVP_EN = 1, OVP_SEL = 1	20	22	23	V
		Supply falling, OVP_EN = 1, OVP_SEL = 1	19	21	22	V
V_{OVP_HYS}	Supply overvoltage protection (OVP) (SPI Device)	Rising to falling threshold, OVP_SEL = 1	0.9	1	1.1	V
		Rising to falling threshold, OVP_SEL = 0	0.7	0.8	0.9	V
t_{OVP}	Supply overvoltage deglitch time		2.5	5	7	μs
V_{CPUV}	Charge pump undervoltage lockout (above VM)	Supply rising	2.3	2.5	2.7	V
		Supply falling	2.2	2.4	2.6	V
V_{CPUV_HYS}	Charge pump UVLO hysteresis	Rising to falling threshold	75	100	140	mV
V_{AVDD_UV}	Analog regulator undervoltage lockout	Supply rising	2.7	2.85	3	V
		Supply falling	2.5	2.65	2.8	V
$V_{AVDD_UV_HYS}$	Analog regulator undervoltage lockout hysteresis	Rising to falling threshold	180	200	240	mV
I_{OCP}	Overcurrent protection trip point (SPI Device)	OCP_LVL = 0b	10	16	20	A
		OCP_LVL = 1b	15	24	28	A
	Overcurrent protection trip point (HW Device)	OCP pin tied to AGND	10	16	21.5	A
		OCP pin tied to AVDD	15	24	31	A
t_{OCP}	Overcurrent protection deglitch time (SPI Device)	OCP_DEG = 00b	0.06	0.3	0.6	μs
		OCP_DEG = 01b	0.3	0.6	1.1	μs
		OCP_DEG = 10b	0.7	1.25	1.8	μs
		OCP_DEG = 11b	1.1	1.6	2.5	μs
	Overcurrent protection deglitch time (HW Device)		0.06	0.3	0.6	μs
t_{RETRY}	Overcurrent protection retry time (SPI Device)	OCP_RETRY = 0	4	5	6	ms
		OCP_RETRY = 1	450	500	560	ms
t_{RETRY}	Overcurrent protection retry time (HW Device)		4	5	6	ms

MCT8316Z

SLVSF18B – MARCH 2021 – REVISED NOVEMBER 2021

 $T_J = -40^{\circ}\text{C}$ to $+150^{\circ}\text{C}$, $V_{VM} = 4.5$ to 35 V (unless otherwise noted). Typical limits apply for $T_A = 25^{\circ}\text{C}$, $V_{VM} = 24$ V

PARAMETER		TEST CONDITIONS	MIN	TYP	MAX	UNIT
t_{MTR_LOCK}	Motor lock detection time (SPI Device)	MOTOR_LOCK_TDET = 00b	270	300	330	ms
		MOTOR_LOCK_TDET = 01b	450	500	550	ms
		MOTOR_LOCK_TDET = 10b	900	1000	1100	ms
		MOTOR_LOCK_TDET = 11b	4500	5000	5500	ms
t_{MTR_LOCK}	Motor lock detection time (HW Device)		900	1000	1100	ms
$t_{MTR_LOCK_RETRY}$	Motor lock retry time (SPI Device)	MOTOR_LOCK_RETRY = 0b	450	500	550	ms
		MOTOR_LOCK_RETRY = 1b	4500	5000	5500	ms
$t_{MTR_LOCK_RETRY}$	Motor lock retry time (HW Device)		450	500	550	ms
T_{OTW}	Thermal warning temperature (FET)	Die temperature (T_J)	160	170	180	$^{\circ}\text{C}$
T_{OTW_HYS}	Thermal warning hysteresis (FET)	Die temperature (T_J)	25	30	35	$^{\circ}\text{C}$
T_{TSD}	Thermal shutdown temperature	Die temperature (T_J)	175	185	195	$^{\circ}\text{C}$
T_{TSD_HYS}	Thermal shutdown hysteresis	Die temperature (T_J)	25	30	35	$^{\circ}\text{C}$
T_{TSD}	Thermal shutdown temperature (FET)	Die temperature (T_J)	170	180	190	$^{\circ}\text{C}$
T_{TSD_HYS}	Thermal shutdown hysteresis (FET)	Die temperature (T_J)	25	30	35	$^{\circ}\text{C}$

 (1) R_{LBK} is resistance of inductor L_{BK}

7.6 SPI Timing Requirements

		MIN	NOM	MAX	UNIT
t_{READY}	SPI ready after power up			1	ms
t_{HI_nSCS}	nSCS minimum high time	300			ns
t_{SU_nSCS}	nSCS input setup time	25			ns
t_{HD_nSCS}	nSCS input hold time	25			ns
t_{SCLK}	SCLK minimum period	100			ns
t_{SCLKH}	SCLK minimum high time	50			ns
t_{SCLKL}	SCLK minimum low time	50			ns
t_{SU_SDI}	SDI input data setup time	25			ns
t_{HD_SDI}	SDI input data hold time	25			ns
t_{DLY_SDO}	SDO output data delay time			25	ns
t_{EN_SDO}	SDO enable delay time			50	ns
t_{DIS_SDO}	SDO disable delay time			50	ns

7.7 SPI Secondary Mode Timings

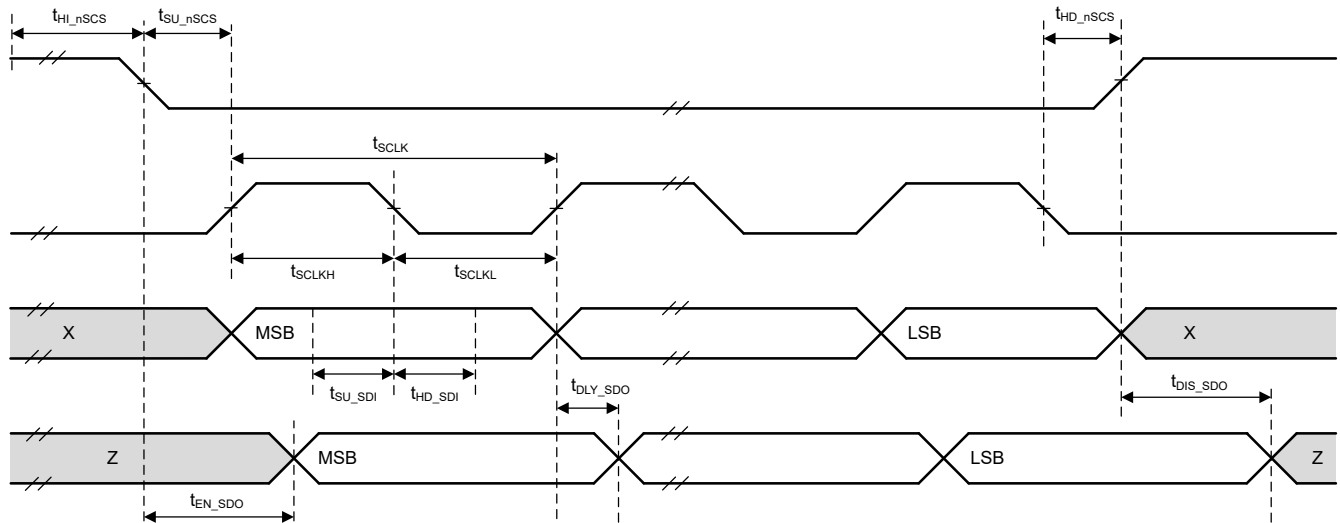

Figure 7-1. SPI Secondary Mode Timing Diagram

7.8 Typical Characteristics

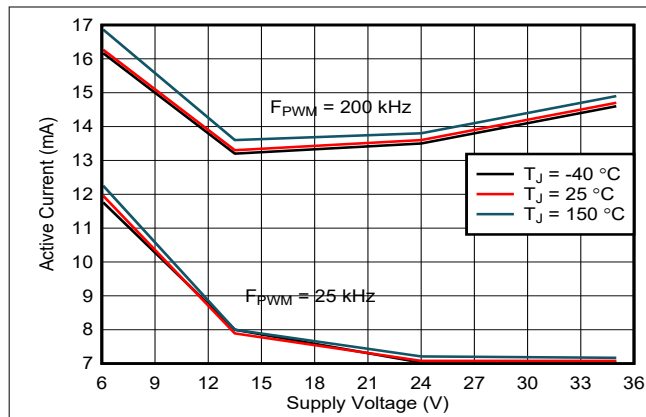

Figure 7-2. Supply current over supply voltage

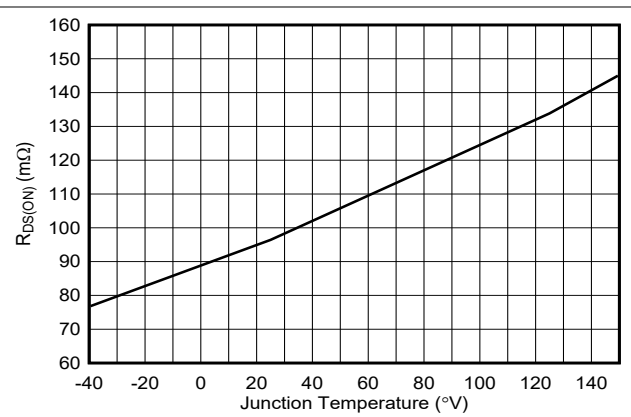

Figure 7-3. $R_{DS(ON)}$ (high and low side combined) for MOSFETs over temperature

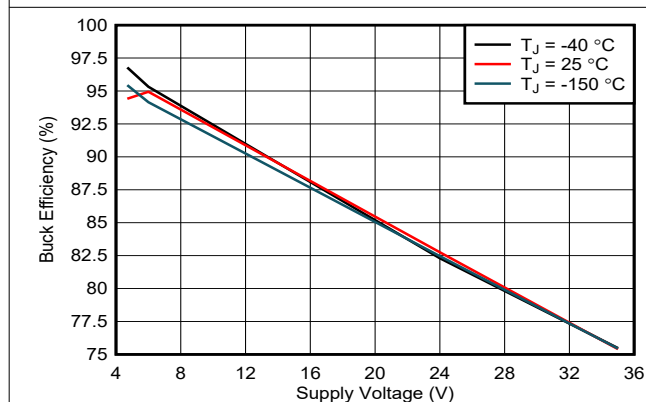

Figure 7-4. Buck regulator efficiency over supply voltage

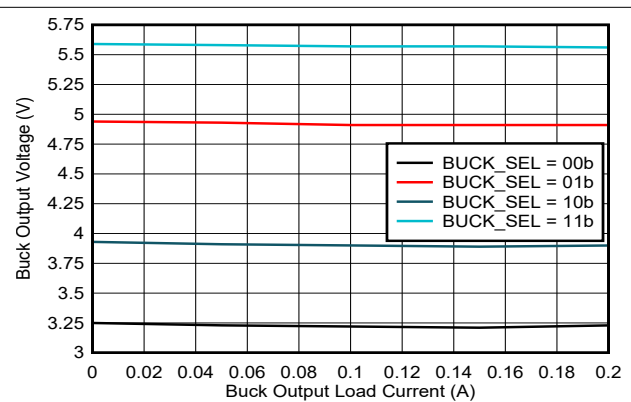

Figure 7-5. Buck regulator output voltage over load current

8 Detailed Description

8.1 Overview

The MCT8316Z device is an integrated 100-m Ω (combined high-side and low-side MOSFET's on-state resistance) driver for 3-phase motor-drive applications. The device reduces system component count, cost, and complexity by integrating three half-bridge MOSFETs, gate drivers, charge pump, linear regulator for the external load and buck regulator. A standard serial peripheral interface (SPI) provides a simple method for configuring the various device settings and reading fault diagnostic information through an external controller. Alternatively, a hardware interface (H/W) option allows for configuring the most commonly used settings through fixed external resistors.

The architecture uses an internal state machine to protect against short-circuit events, and protect against dv/dt parasitic turnon of the internal power MOSFET.

The MCT8316Z device integrates three-phase sensed trapezoidal commutation using analog or digital hall sensors for position detection.

In addition to the high level of device integration, the MCT8316Z device provides a wide range of integrated protection features. These features include power-supply undervoltage lockout (UVLO), charge-pump undervoltage lockout (CPUV), overcurrent protection (OCP), AVDD undervoltage lockout (AVDD_UV), buck regulator ULVO for MCT8316ZR/T and overtemperature shutdown (OTW and OTSD). Fault events are indicated by the nFAULT pin with detailed information available in the SPI registers on the SPI device version.

The MCT8316ZT and MCT8316ZR device are available in 0.5-mm pin pitch, VQFN surface-mount packages. The VQFN package size is 7 mm \times 5 mm.

8.2 Functional Block Diagram

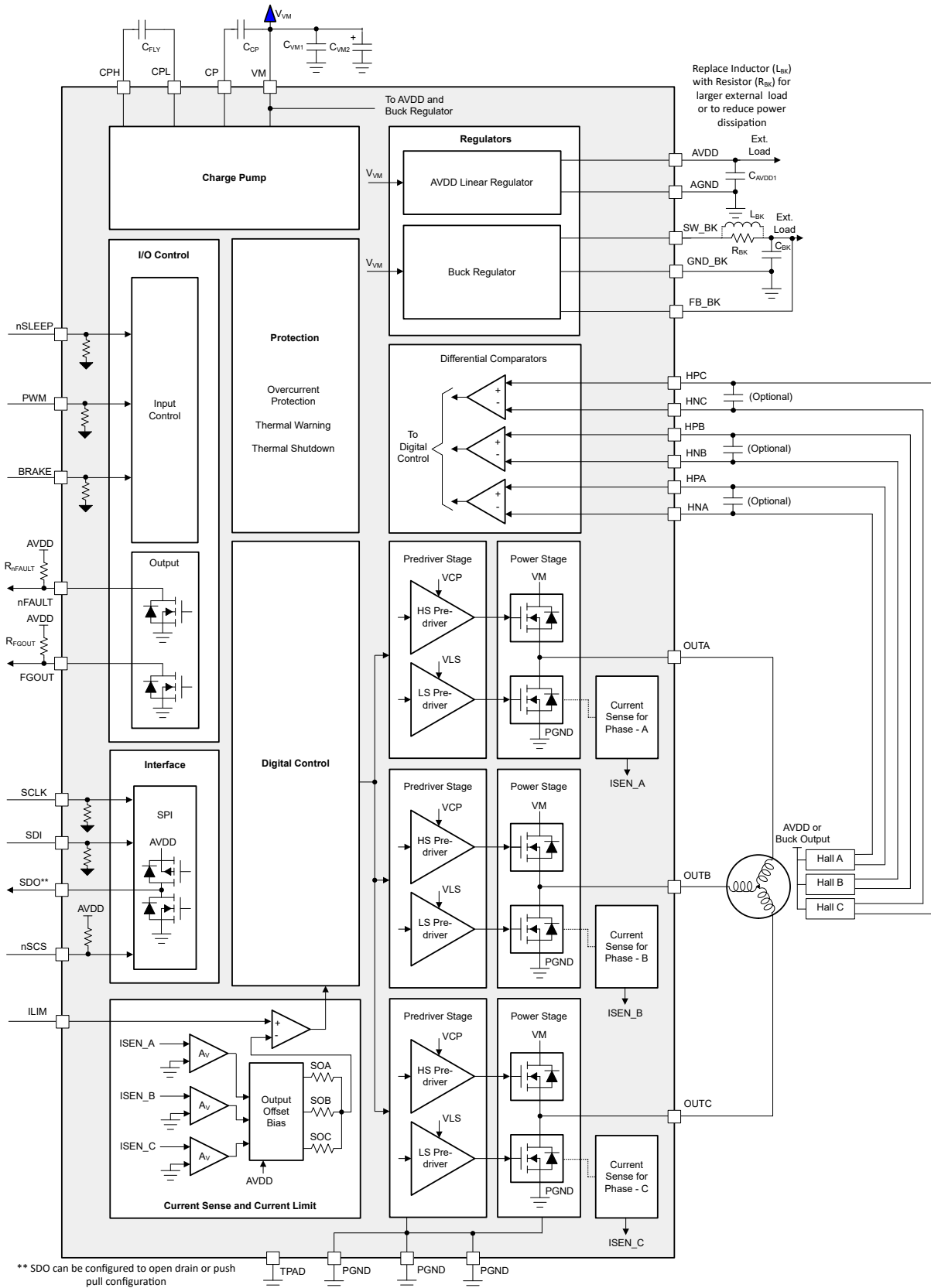

Figure 8-1. MCT8316ZR Block Diagram

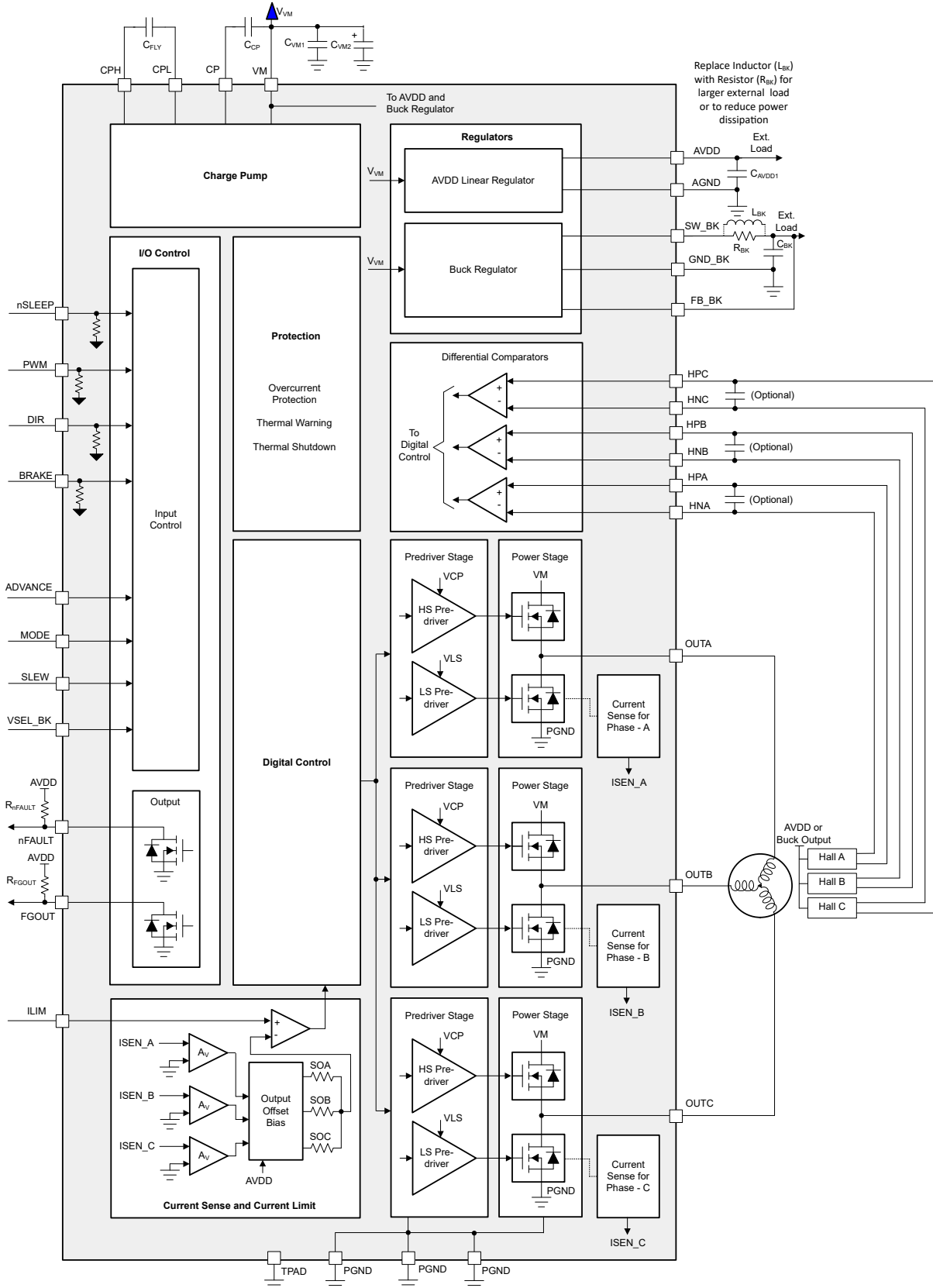

Figure 8-2. MCT8316ZT Block Diagram

8.3 Feature Description

Table 8-1 lists the recommended values of the external components for the driver.

Note

TI recommends to connect pull up on nFAULT even if it is not used to avoid undesirable entry into internal test mode. If external supply is used to pull up nFAULT, ensure that it is pulled to >2.2V on power up or the device will enter internal test mode.

Table 8-1. MCT8316Z External Components

COMPONENTS	PIN 1	PIN 2	RECOMMENDED
C _{VM1}	VM	PGND	X5R or X7R, 0.1- μ F, TI recommends a capacitor voltage rating at least twice the normal operating voltage of the device
C _{VM2}	VM	PGND	≥ 10 - μ F, TI recommends a capacitor voltage rating at least twice the normal operating voltage of the device
C _{CP}	CP	VM	X5R or X7R, 16-V, 1- μ F capacitor
C _{FLY}	CPH	CPL	X5R or X7R, 47-nF, TI recommends a capacitor voltage rating at least twice the normal operating voltage of the pin
C _{AVDD}	AVDD	AGND	X5R or X7R, 1- μ F, ≥ 6.3 -V. In order for AVDD to accurately regulate output voltage, capacitor should have effective capacitance between 0.7- μ F to 1.3- μ F at 3.3-V across operating temperature.
C _{BK}	SW_BK	GND_BK	X5R or X7R, 22- μ F, buck-output rated capacitor. TI recommends a capacitor voltage rating at least twice the normal operating voltage of the pin
L _{BK}	SW_BK	FB_BK	Output inductor
R _{nFAULT}	VCC	nFAULT	5.1-k Ω , Pullup resistor
R _{MODE}	MODE	AGND or AVDD	MCT8316Z hardware interface
R _{SLEW}	SLEW	AGND or AVDD	MCT8316Z hardware interface
R _{ADVANCE}	ADVANCE	AGND or AVDD	MCT8316Z hardware interface
R _{VSEL_BK}	VSEL_BK	AGND or AVDD	MCT8316Z hardware interface
C _{ILIM}	ILIM	AGND	X5R or X7R, 0.1- μ F, AVDD-rated capacitor (Optional)

8.3.1 Output Stage

The MCT8316Z device consists of an integrated 100-m Ω (combined high-side and low-side FET's on-state resistance) NMOS FETs connected in a three-phase bridge configuration. A doubler charge pump provides the proper gate-bias voltage to the high-side NMOS FET's across a wide operating-voltage range in addition to providing 100% duty-cycle support. An internal linear regulator provides the gate-bias voltage for the low-side MOSFETs. The device has three VM motor power-supply pins which are to be connected together to the motor-supply voltage.

8.3.2 PWM Control Mode (1x PWM Mode)

The MCT8316Z family of devices provides seven different control modes to support various commutation and control methods. The MCT8316Z device provides a 1x PWM control mode for driving the BLDC motor in trapezoidal current-control mode. The MCT8316Z device uses 6-step block commutation tables that are stored internally. This feature lets a three-phase BLDC motor be controlled using a single PWM sourced from a simple controller. The PWM is applied on the PWM pin and determines the output frequency and duty cycle of the half-bridges.

The MCT8316Z family of devices supports both analog and digital hall inputs by changing mode input setting. Differential hall inputs should be connected to HPx and HNx pins (see Figure 8-3). Digital hall inputs should be connected to the HPx pins while keeping the HNx pins floating (see Figure 8-4).

The half-bridge output states are managed by the HPA, HNA, HPB, HNB, HPC and HNC pins in analog mode and HPA, HPB, HPC in digital mode which are used as state logic inputs. The state inputs are the position feedback of the BLDC motor. The 1x PWM mode usually operates with synchronous rectification (low-side MOSFET recirculation); however, the mode can be configured to use asynchronous rectification (MOSFET body diode freewheeling) as shown below

Table 8-2. PWM_MODE Configuration

MODE Type	MODE Pin (Hardware Variant)	Hall Configuration	Modulation	ASR and AAR Mode
Mode 1	Connected to AGND	Analog Hall Input	Asynchronous	ASR and AAR Disabled
Mode 2	Connected to AGND with R _{MODE1}	Digital Hall Input	Asynchronous	ASR and AAR Disabled
Mode 3	Connected to AGND with R _{MODE2}	Analog Hall Input	Synchronous	ASR and AAR Disabled
Mode 4	Hi-Z	Digital Hall Input	Synchronous	ASR and AAR Disabled
Mode 5	Connected to AVDD with R _{MODE2}	Analog Hall Input	Synchronous	ASR and AAR Enabled
Mode 6	Connected to AVDD with R _{MODE1}	Digital Hall Input	Synchronous	ASR and AAR Enabled
Mode 7	Connected to AVDD			

Note

Texas Instruments does not recommend changing the MODE pin or PWM_MODE register during operation of the power MOSFETs. Set PWM to a low level before changing the MODE pin or PWM_MODE register.

8.3.2.1 Analog Hall Input Configuration

Figure 8-3 shows the connection of Analog Hall inputs to the driver. Analog hall elements are fed to the hall comparators, which zero crossing is used to generate the commutation logic.

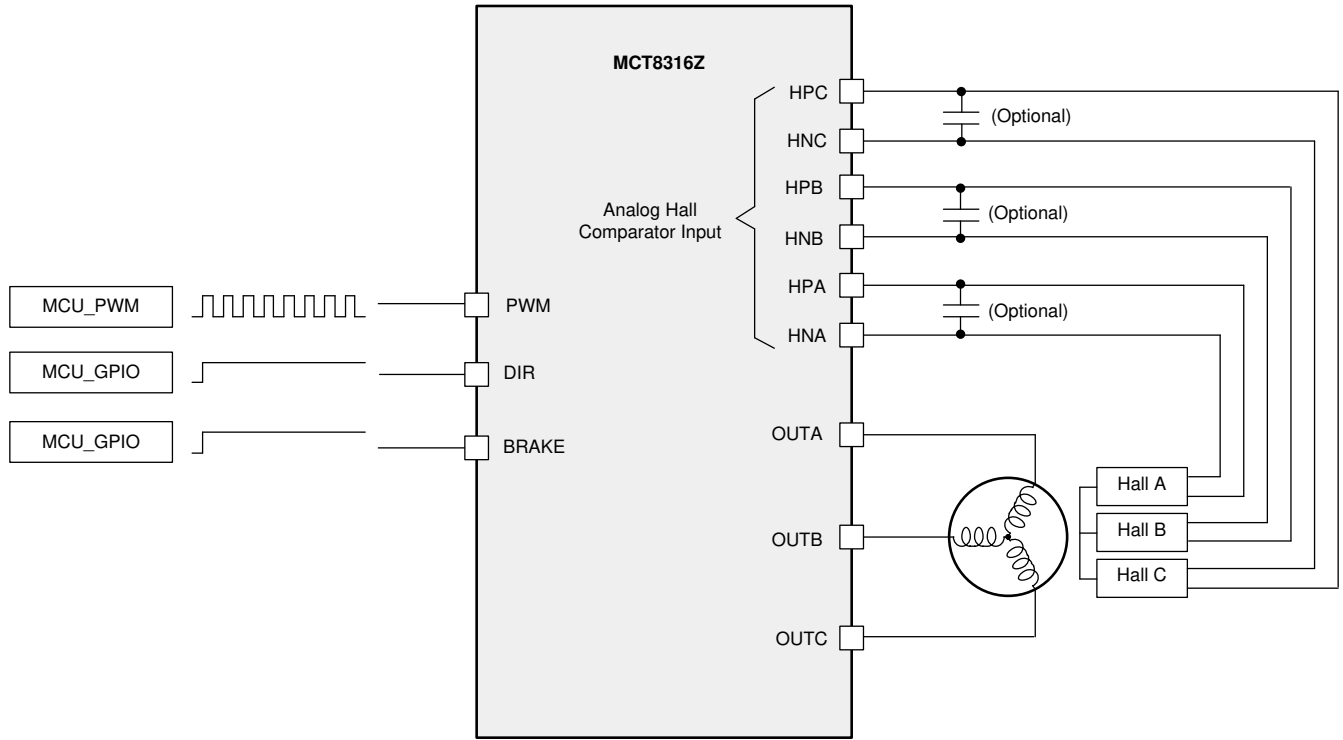

Figure 8-3. 1x PWM Mode with Analog Hall Input

Note

Texas Instruments recommends motor direction (DIR) change when the motor is stationary.

8.3.2.2 Digital Hall Input Configuration

Figure 8-4 shows the connection of Digital Hall inputs to the driver.

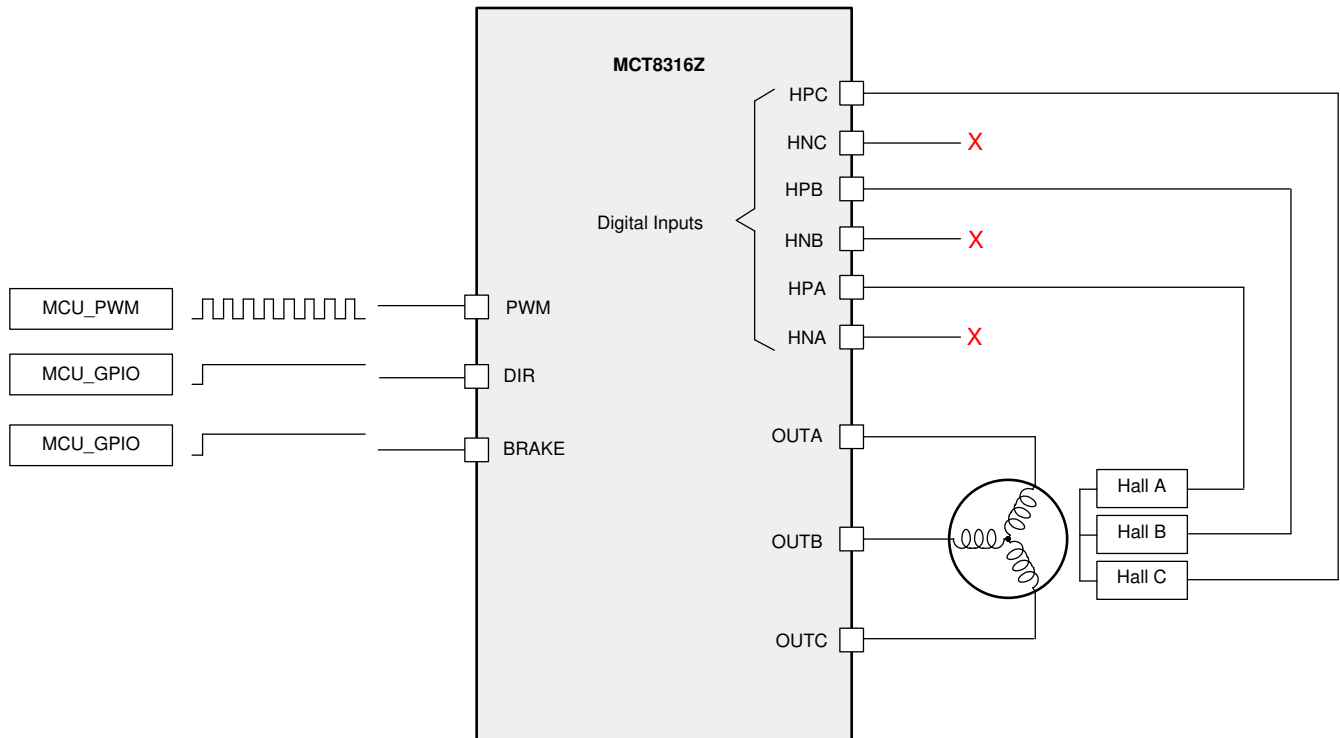

Figure 8-4. 1x PWM Mode with Digital Hall Input

8.3.2.3 Asynchronous Modulation

The DIR pin controls the direction of BLDC motor in either clockwise or counter-clockwise direction. Tie the DIR pin low if this feature is not required.

The BRAKE input halts the motor by turning off all high-side MOSFETs and turning on all low-side MOSFETs when it is pulled high. This brake is independent of the states of the other input pins. Tie the BRAKE pin low if this feature is not required.

Table 8-3 shows the configuration in 1x PWM mode with asynchronous modulation.

Table 8-3. Asynchronous Modulation

STATE	HALL INPUTS						DRIVER OUTPUTS						DESCRIPTION
	DIR = 0			DIR = 1			PHASE A		PHASE B		PHASE C		
	HALL_A /HPA	HALL_B /HPB	HALL_C /HPC	HALL_A /HPA	HALL_B /HPB	HALL_C /HPC	High Side	Low Side	High Side	Low Side	High Side	Low Side	
Stop	0	0	0	0	0	0	L	L	L	L	L	L	Stop
Align	1	1	1	1	1	1	PWM	L	L	H	L	H	Align
1	1	1	0	0	0	1	L	L	PWM	L	L	H	B → C
2	1	0	0	0	1	1	PWM	L	L	L	L	H	A → C
3	1	0	1	0	1	0	PWM	L	L	H	L	L	A → B
4	0	0	1	1	1	0	L	L	L	H	PWM	L	C → B
5	0	1	1	1	0	0	L	H	L	L	PWM	L	C → A
6	0	1	0	1	0	1	L	H	PWM	L	L	L	B → A

8.3.2.4 Synchronous Modulation

Table 8-4 shows the configuration in 1x PWM mode with synchronous modulation.

Table 8-4. Synchronous Modulation

STATE	HALL INPUTS						DRIVER OUTPUTS						DESCRIPTION
	DIR = 0			DIR = 1			PHASE A		PHASE B		PHASE C		
	HALL_A /HPA	HALL_B /HPB	HALL_C /HPC	HALL_A /HPA	HALL_B /HPB	HALL_C /HPC	High Side	Low Side	High Side	Low Side	High Side	Low Side	
Stop	0	0	0	0	0	0	L	L	L	L	L	L	Stop
Align	1	1	1	1	1	1	PWM	!PWM	L	H	L	H	Align
1	1	1	0	0	0	1	L	L	PWM	!PWM	L	H	B → C
2	1	0	0	0	1	1	PWM	!PWM	L	L	L	H	A → C
3	1	0	1	0	1	0	PWM	!PWM	L	H	L	L	A → B
4	0	0	1	1	1	0	L	L	L	H	PWM	!PWM	C → B
5	0	1	1	1	0	0	L	H	L	L	PWM	!PWM	C → A
6	0	1	0	1	0	1	L	H	PWM	!PWM	L	L	B → A

8.3.2.5 Motor Operation

Figure 8-5 and Figure 8-6 shows the BLDC motor commutation with direction setting (DIR) as 0 and 1 respectively.

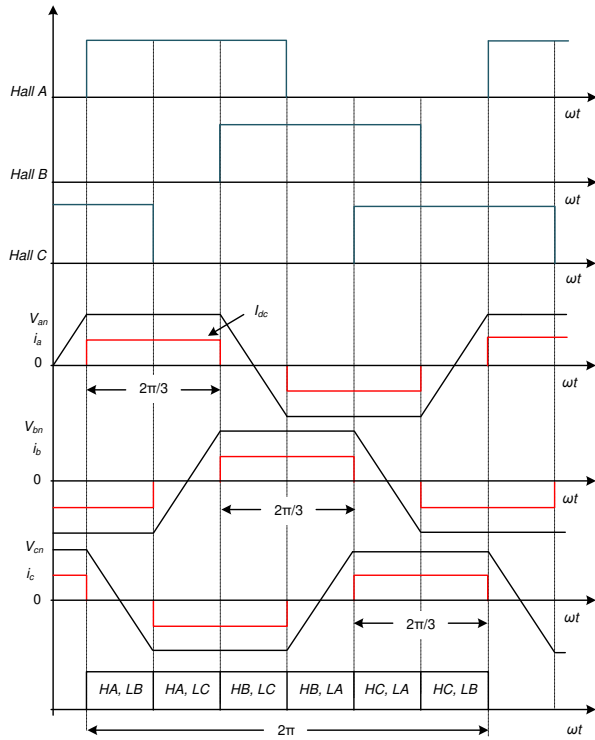

Figure 8-5. BLDC Motor Commutation with DIR = 0

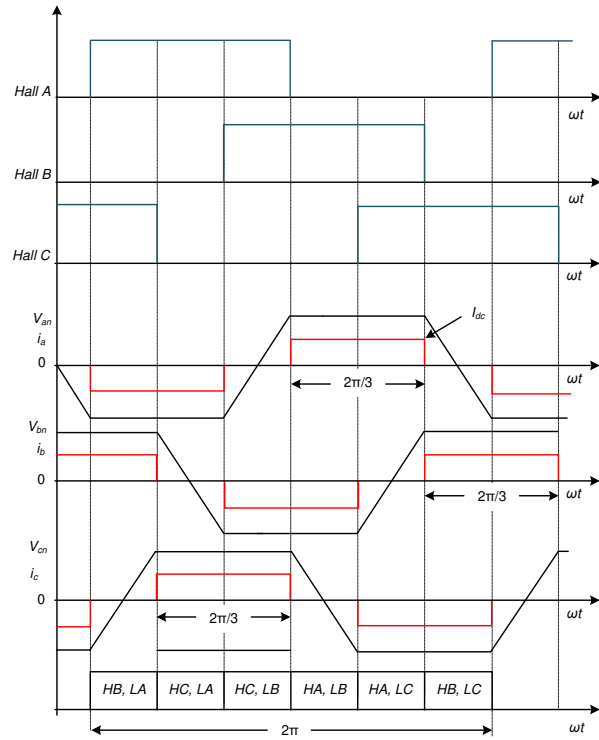

Figure 8-6. BLDC Motor Commutation with DIR = 1

8.3.3 Device Interface Modes

The MCT8316Z family of devices supports two different interface modes (SPI and hardware) to let the end application design for either flexibility or simplicity. The two interface modes share the same four pins, allowing the different versions to be pin-to-pin compatible. This compatibility lets application designers evaluate with one interface version and potentially switch to another with minimal modifications to their design.

8.3.3.1 Serial Peripheral Interface (SPI)

The SPI devices support a serial communication bus that lets an external controller send and receive data with the MCT8316Z. This support lets the external controller configure device settings and read detailed fault information. The interface is a four wire interface using the SCLK, SDI, SDO, and nSCS pins which are described as follows:

- The SCLK pin is an input that accepts a clock signal to determine when data is captured and propagated on the SDI and SDO pins.
- The SDI pin is the data input.
- The SDO pin is the data output. The SDO pin can be configured to either open-drain or push-pull through SDO_MODE.
- The nSCS pin is the chip select input. A logic low signal on this pin enables SPI communication with the MCT8316Z.

For more information on the SPI, see the [Section 8.5](#) section.

8.3.3.2 Hardware Interface

Hardware interface devices convert the four SPI pins into four resistor-configurable inputs which are ADVANCE, MODE, SLEW and VSEL_BK.

This conversion lets the application designer configure the most common device settings by tying the pin logic high or logic low, or with a simple pullup or pulldown resistor. This removes the requirement for an SPI bus from the external controller. General fault information can still be obtained through the nFAULT pin.

- The MODE pin configures the PWM control mode.
- The SLEW pin configures the slew rate of the output voltage.
- The ADVANCE pin configures the lead angle of the output with respect to hall signals.
- The VSEL_BK pin is used to configure the buck regulator voltage.

For more information on the hardware interface, see the [Section 8.3.10](#) section.

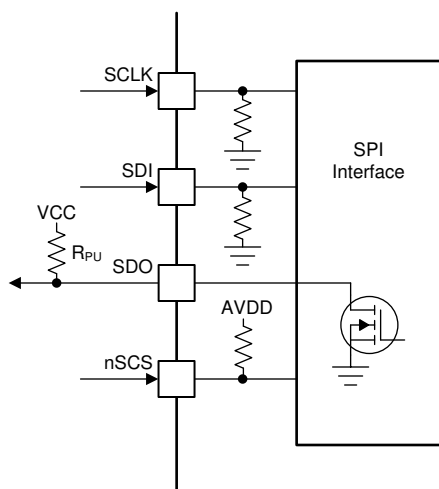

Figure 8-7. MCT8316ZR SPI Interface

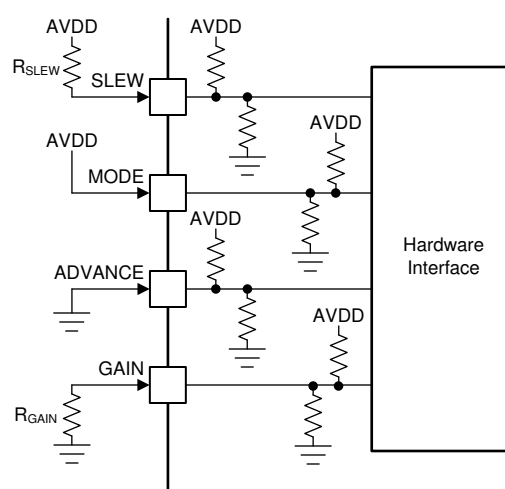

Figure 8-8. MCT8316ZT Hardware Interface

8.3.4 Step-Down Mixed-Mode Buck Regulator

The MCT8316ZR and MCT8316ZT has an integrated mixed-mode buck regulator in conjunction with AVDD to supply regulated 3.3 V or 5.0 V power for an external controller or system voltage rail. Additionally, the buck output can also be configured to 4.0 V or 5.7 V for supporting the extra headroom for external LDO for generating a 3.3 V or 5.0 V supplies. The output voltage of the buck is set by the VSEL_BK pin in the MCT8316ZT device (hardware variant) and BUCK_SEL bits in the MCT8316ZR device (SPI variant).

The buck regulator has a low quiescent current of ~1-2 mA during light loads to prolong battery life. The device improves performance during line and load transients by implementing a pulse-frequency current-mode control scheme which requires less output capacitance and simplifies frequency compensation design.

To disable the buck regulator, set the BUCK_DIS bit in the MCT8316ZR (SPI variant). The buck regulator cannot be disabled in the MCT8316ZT (hardware variant).

Note

If the buck regulator is unused, the buck pins SW_BK, GND_BK, and FB_BK cannot be left floating or connected to ground. The buck regulator components L_{BK}/R_{BK} and C_{BK} must be connected in hardware.

Table 8-5. Recommended settings for Buck Regulator

Buck Mode	Buck output voltage	Max output current from AVDD (I_{AVDD})	Max output current from Buck (I_{BK})	Buck current limit	AVDD power sequencing
Inductor - 47 μ H	3.3 V or 4.0 V	30 mA	200 mA - I_{AVDD}	600 mA (BUCK_CL = 0b)	Not supported (BUCK_PS_DIS = 1)
Inductor - 47 μ H	5.0 V or 5.7 V	30 mA	200 mA - I_{AVDD}	600 mA (BUCK_CL = 0b)	Supported (BUCK_PS_DIS = 0)
Inductor - 22 μ H	5.0 V or 5.7 V	30 mA	50 mA - I_{AVDD}	150 mA (BUCK_CL = 1b)	Not supported (BUCK_PS_DIS = 1)
Inductor - 22 μ H	3.3 V or 4.0 V	30 mA	50 mA - I_{AVDD}	150 mA (BUCK_CL = 1b)	Supported (BUCK_PS_DIS = 0)
Resistor - 22 μ H	5.0 V or 5.7 V	30 mA	40 mA - I_{AVDD}	150 mA (BUCK_CL = 1b)	Not supported (BUCK_PS_DIS = 1)
Resistor - 22 μ H	3.3 V or 4.0 V	30 mA	40 mA - I_{AVDD}	150 mA (BUCK_CL = 1b)	Supported (BUCK_PS_DIS = 0)

8.3.4.1 Buck in Inductor Mode

The buck regulator in MCT8316Z device is primarily designed to support low inductance of $47\mu\text{H}$ and $22\mu\text{H}$ inductors. The $47\mu\text{H}$ inductor allows the buck regulator to operate up to 200 mA load current support, whereas the $22\mu\text{H}$ inductor limits the load current to 50 mA.

Figure 8-9 shows the connection of buck regulator in inductor mode.

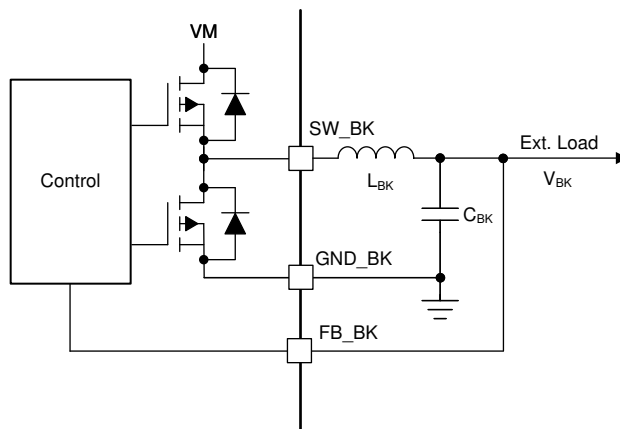

Figure 8-9. Buck (Inductor Mode)

8.3.4.2 Buck in Resistor mode

If the external load requirements is less than 40mA, the inductor can be replaced with a resistor. In resistor mode the power is dissipated across the external resistor and the efficiency is lower than buck in inductor mode.

Figure 8-10 shows the connection of buck regulator in resistor mode.

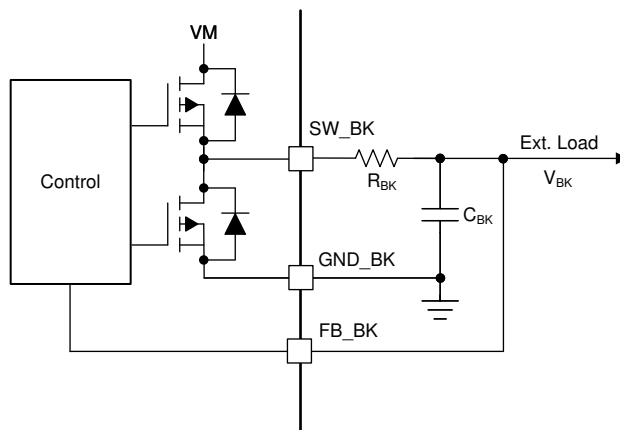

Figure 8-10. Buck (Resistor Mode)

8.3.4.3 Buck Regulator with External LDO

The buck regulator also supports the voltage requirement to feed to external LDO to generate standard 3.3 V or 5.0 V output rail with higher accuracies. The buck output voltage should be configured to 4 V or 5.5 V to provide for a extra headroom to support the external LDO for generating 3.3 V or 5 V rail as shown in [Figure 8-11](#).

This allows for a lower-voltage LDO design to save cost and better thermal management due to low drop-out voltage.

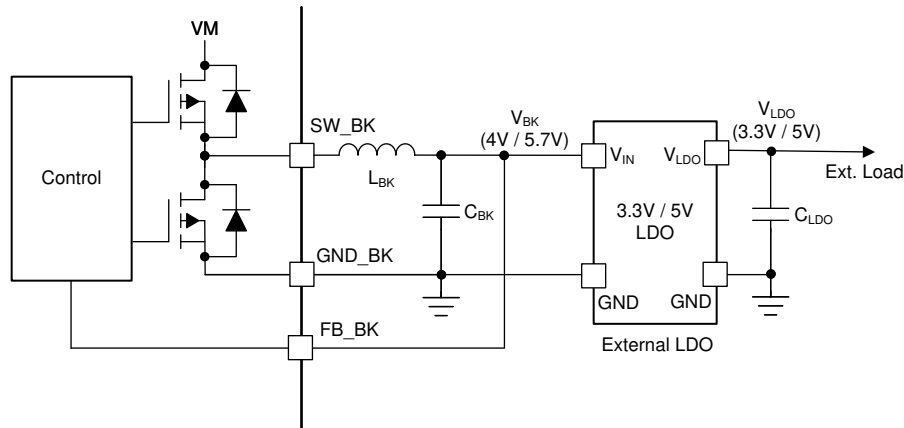

Figure 8-11. Buck Regulator with External LDO

8.3.4.4 AVDD Power Sequencing on Buck Regulator

The AVDD LDO has an option of using the power supply from mixed mode buck regulator to reduce power dissipation internally. The power sequencing mode allows on-the-fly changeover of LDO power supply from DC mains (VM) to buck output (VBK) as shown in [Figure 8-12](#). This sequencing can be configured through the BUCK_PS_DIS bit . Power sequencing is supported only when buck output voltage is set to 5.0 V or 5.7 V.

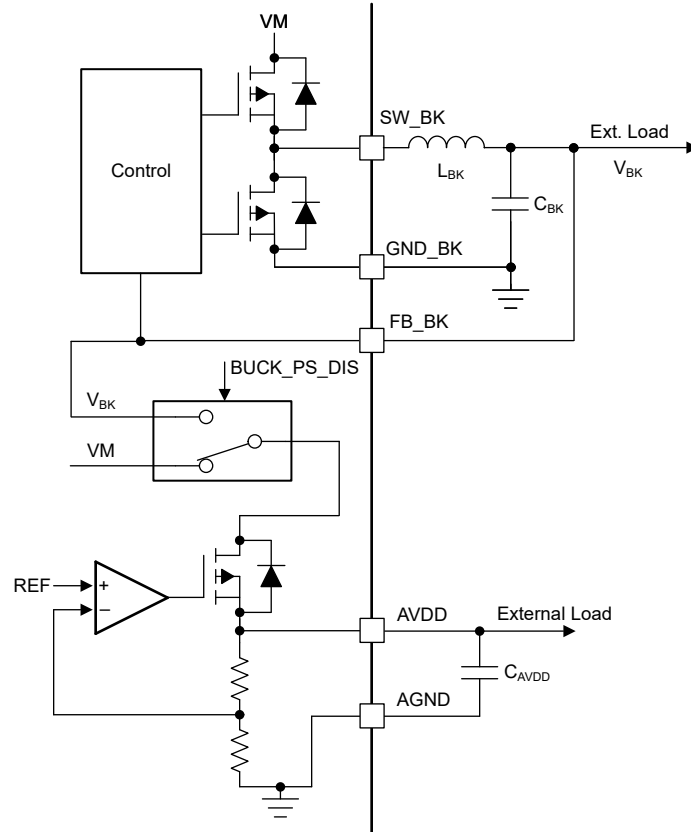

Figure 8-12. AVDD Power Sequencing on mixed mode Buck Regulator

8.3.4.5 Mixed mode Buck Operation and Control

The buck regulator implements a pulse frequency modulation (PFM) architecture with peak current mode control. The output voltage of the buck regulator is compared with the internal reference voltage (V_{BK_REF}) which is internally generated depending on the buck-output voltage setting (BUCK_SEL) which constitutes an outer voltage control loop. Depending on the comparator output going high ($V_{BK} < V_{BK_REF}$) or low ($V_{BK} > V_{BK_REF}$), the high-side power FET of the buck turns on and turns off respectively. An independent current control loop monitors the current in high-side power FET (I_{BK}) and turns off the high-side FET when the current becomes higher than the buck current limit (I_{BK_CL}). This implements a current limit control for the buck regulator. Figure 8-13 shows the architecture of the buck and various control/protection loops.

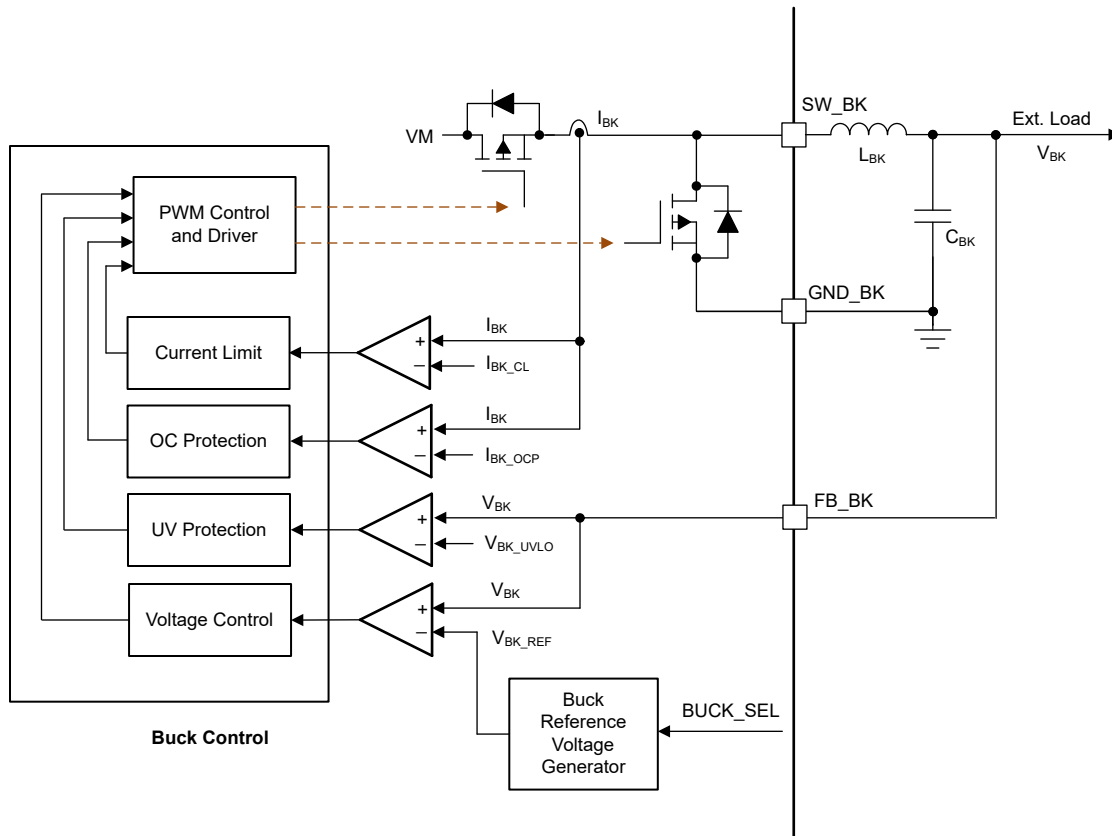

Figure 8-13. Buck Operation and Control Loops

8.3.5 AVDD Linear Voltage Regulator

A 3.3-V, linear regulator is integrated into the MCT8316Z family of devices and is available for use by external circuitry. The AVDD regulator is used for powering up the internal digital circuitry of the device and additionally, this regulator can also provide the supply voltage for a low-power MCU or other circuitry supporting low current (up to 30 mA). The output of the AVDD regulator should be bypassed near the AVDD pin with a X5R or X7R, 1- μ F, 6.3-V ceramic capacitor routed directly back to the adjacent AGND ground pin.

The AVDD nominal, no-load output voltage is 3.3V.

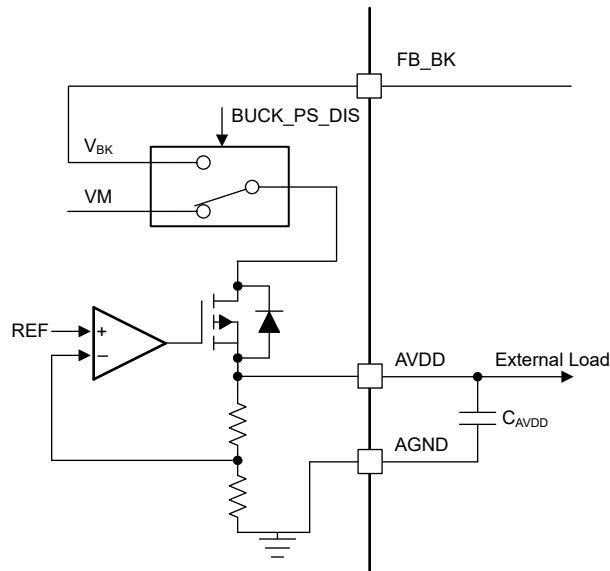

Figure 8-14. AVDD Linear Regulator Block Diagram

Use [Equation 1](#) to calculate the power dissipated in the device by the AVDD linear regulator with VM as supply (BUCK_PD_DIS = 1)

$$P = (V_{VM} - V_{AVDD}) \times I_{AVDD} \quad (1)$$

For example, at a V_{VM} of 24 V, drawing 20 mA out of AVDD results in a power dissipation as shown in [Equation 2](#).

$$P = (24 \text{ V} - 3.3 \text{ V}) \times 20 \text{ mA} = 414 \text{ mW} \quad (2)$$

Use [Equation 3](#) to calculate the power dissipated in the device by the AVDD linear regulator with buck output as supply (BUCK_PD_DIS = 0)

$$P = (V_{FB_BK} - V_{AVDD}) \times I_{AVDD} \quad (3)$$

8.3.6 Charge Pump

Because the output stages use N-channel FETs, the device requires a gate-drive voltage higher than the VM power supply to enhance the high-side FETs fully. The MCT8316Z integrates a charge-pump circuit that generates a voltage above the VM supply for this purpose.

The charge pump requires two external capacitors for operation. See the block diagram, pin descriptions and see section (Section 8.3) for details on these capacitors (value, connection, and so forth).

The charge pump shuts down when nSLEEP is low.

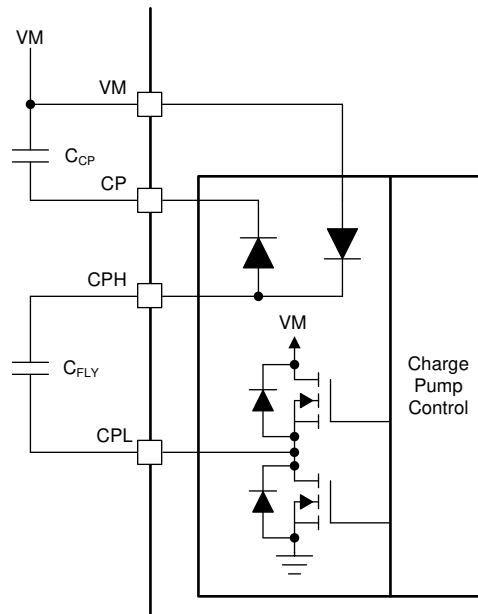

Figure 8-15. MCT8316Z Charge Pump

8.3.7 Slew Rate Control

An adjustable gate-drive current control to the MOSFETs of half-bridges is implemented to achieve the slew rate control. The MOSFET VDS slew rates are a critical factor for optimizing radiated emissions, energy and duration of diode recovery spikes, and switching voltage transients related to parasitics. These slew rates are predominantly determined by the rate of gate charge to internal MOSFETs as shown in Figure 8-16.

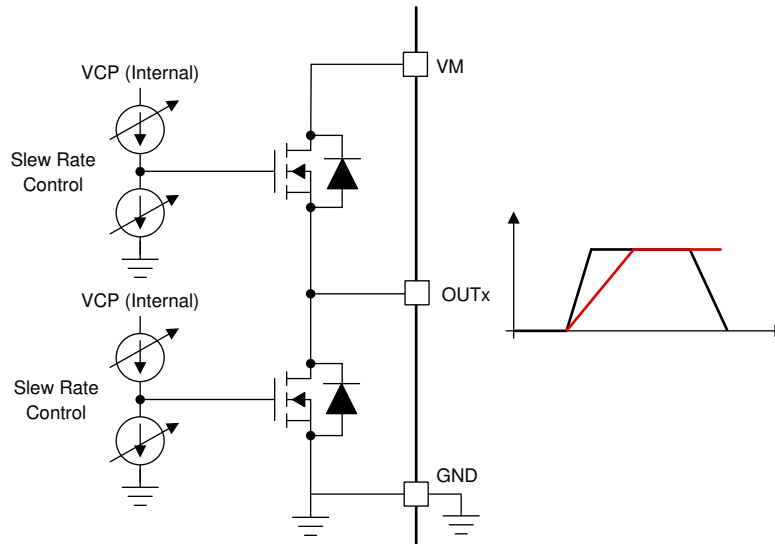

Figure 8-16. Slew Rate Circuit Implementation

The slew rate of each half-bridge can be adjusted by the SLEW pin in hardware device variant or by using the SLEW bits in SPI device variant. Each half-bridge can be selected to either of a slew rate setting of 25-V/ μ s, 50-V/ μ s, 125-V/ μ s or 200-V/ μ s. The slew rate is calculated by the rise time and fall time of the voltage on OUTx pin as shown in Figure 8-17.

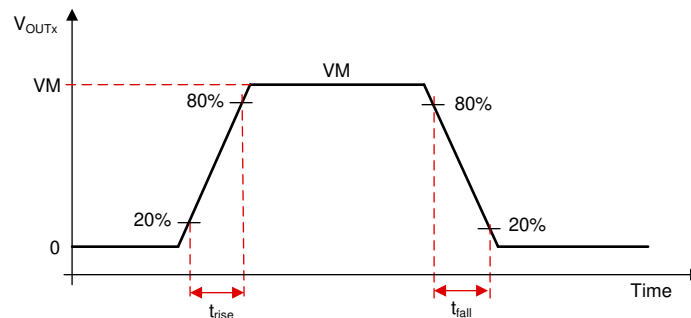

Figure 8-17. Slew Rate Timings

8.3.8 Cross Conduction (Dead Time)

The device is fully protected for any cross conduction of MOSFETs. In half-bridge configuration, the operation of high-side and low-side MOSFETs are ensured to avoid any shoot-through currents by inserting a dead time (t_{dead}). This is implemented by sensing the gate-source voltage (VGS) of the high-side and low-side MOSFETs and ensuring that VGS of high-side MOSFET has reached below turn-off levels before switching on the low-side MOSFET of same half-bridge as shown in Figure 8-18 and Figure 8-19.

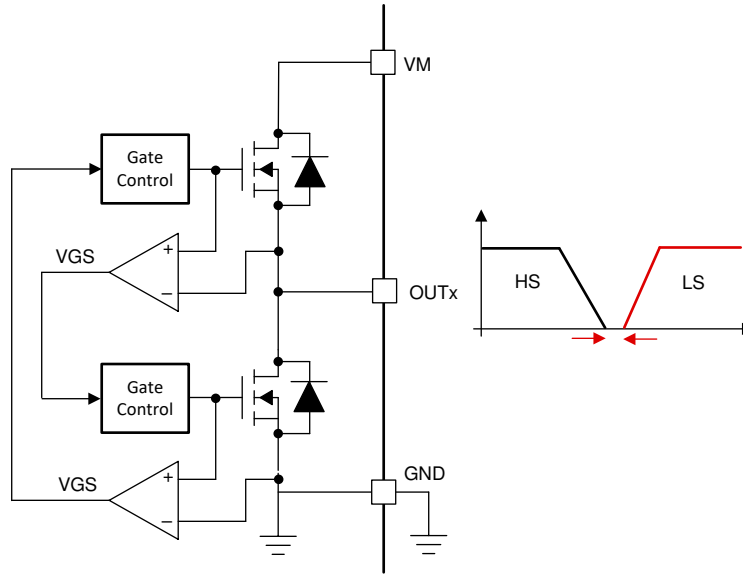

Figure 8-18. Cross Conduction Protection

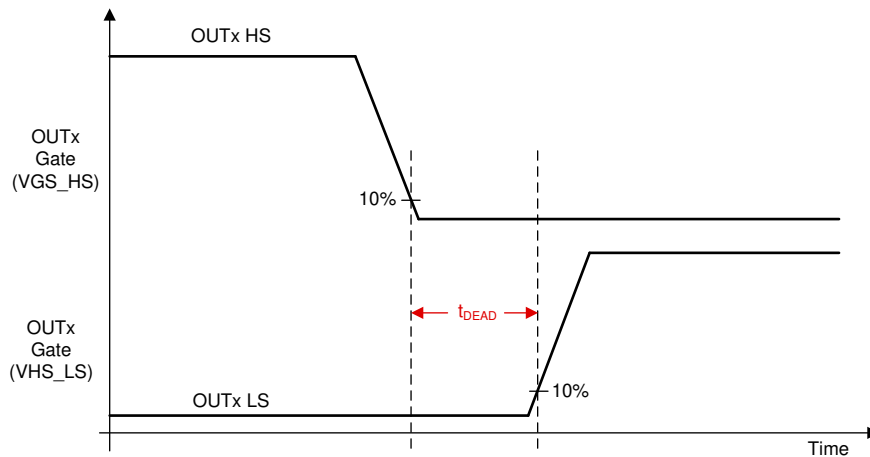

Figure 8-19. Dead Time

8.3.9 Propagation Delay

The propagation delay time (t_{pd}) is measured as the time between an input logic edge to change in gate driver voltage. This time has three parts consisting of the digital input deglitcher delay, analog driver, and comparator delay.

The input deglitcher prevents high-frequency noise on the input pins from affecting the output state of the gate drivers. To support multiple control modes, a small digital delay is added as the input command propagates through the device.

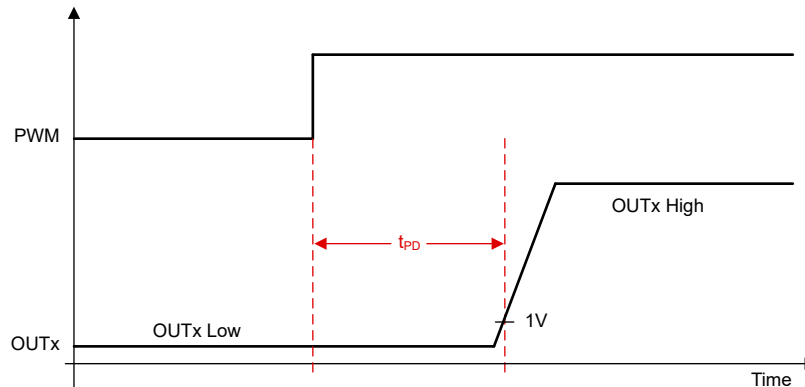

Figure 8-20. Propagation Delay Timing

8.3.9.1 Driver Delay Compensation

MCT8316Z monitors the propagation delay internally and adds a variable delay on top of it to provide fixed delay as shown in Figure 8-21 and Figure 8-22. Delay compensation feature reduces uncertainty caused in timing of current measurement and also reduces duty cycle distortion caused due to propagation delay.

The fixed delay is summation of propagation delay (t_{pd}) caused to internal driver delay and variable delay (t_{VAR}) added to compensate for uncertainty. The fixed delay can be configured through DLY_TARGET register. Refer Table 8-6 for recommendation on configuration for DLY_TARGET for different slew rate settings.

Delay compensation is only available in SPI variant MCT8316ZR and can be enabled by configuring DLYCMP_EN and DLY_TARGET. It is disabled in hardware variant MCT8316ZT

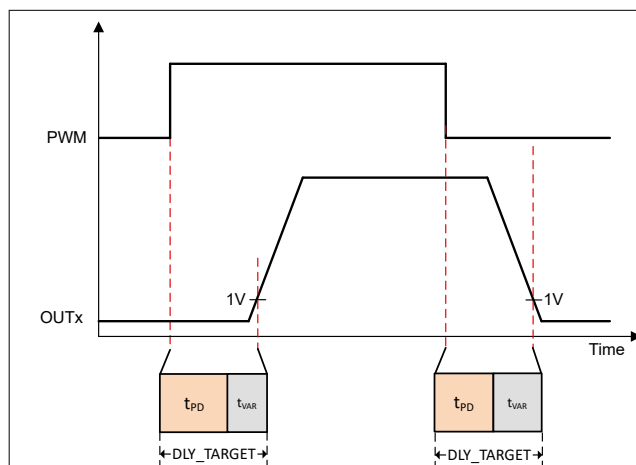

Figure 8-21. Delay Compensation with current flowing out of phase

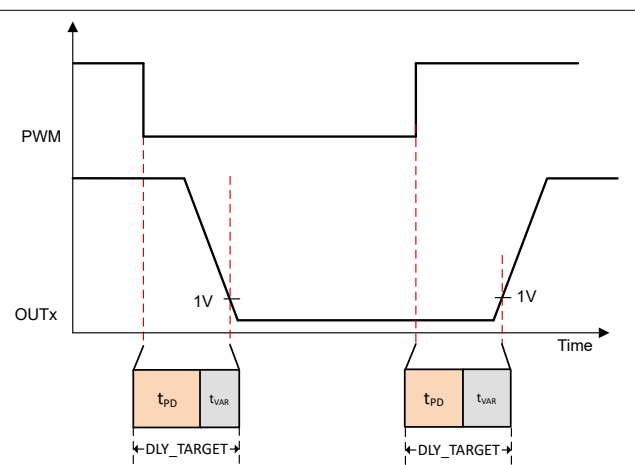

Figure 8-22. Delay Compensation with current flowing into the phase

Table 8-6. Delay Target Recommendation

SLEW RATE	DLY_TARGET
200 V/ μ s	DLY_TARGET = 0x5 (1.2 μ s)
125 V/ μ s	DLY_TARGET = 0x8 (1.8 μ s)
50 V/ μ s	DLY_TARGET = 0xB (2.4 μ s)
25 V/ μ s	DLY_TARGET = 0xF (3.2 μ s)

8.3.10 Pin Diagrams

This section presents the I/O structure of all digital input and output pins.

8.3.10.1 Logic Level Input Pin (Internal Pulldown)

Figure 8-23 shows the input structure for the logic level pins, BRAKE, DIR, DRVOFF, nSLEEP, PWM, SCLK and SDI. The input can be with a voltage or external resistor. It is recommended to put these pins low in device sleep mode to reduce leakage current through internal pull-down resistors.

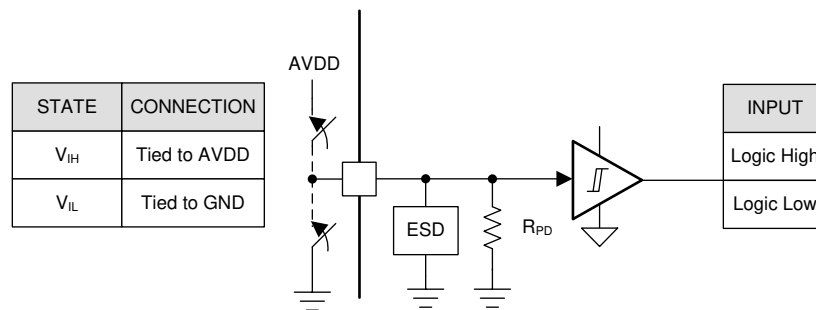

Figure 8-23. Logic-Level Input Pin Structure

8.3.10.2 Logic Level Input Pin (Internal Pullup)

Figure 8-24 shows the input structure for the logic level pin, nSCS. The input can be driven with a voltage or external resistor.

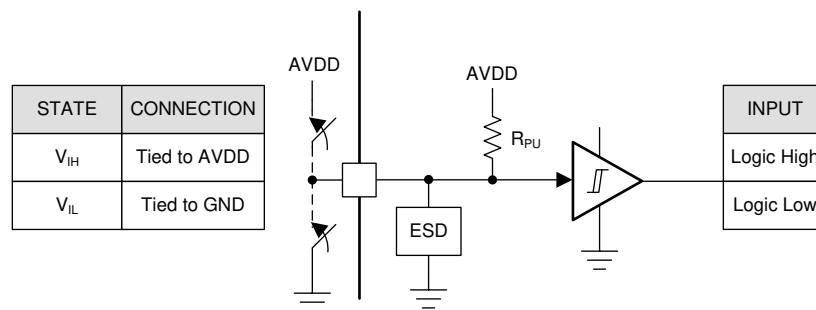

Figure 8-24. Logic nSCC

8.3.10.3 Open Drain Pin

Figure 8-25 shows the structure of the open-drain output pins, nFAULT, FGOUT and SDO in open drain mode. The open-drain output requires an external pullup resistor to function properly.

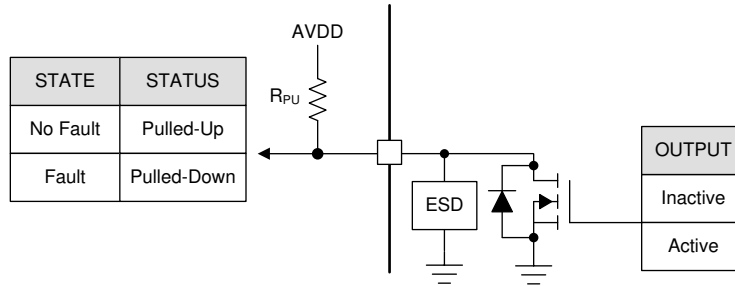

Figure 8-25. Open Drain

8.3.10.4 Push Pull Pin

Figure 8-26 shows the structure of SDO in push-pull mode.

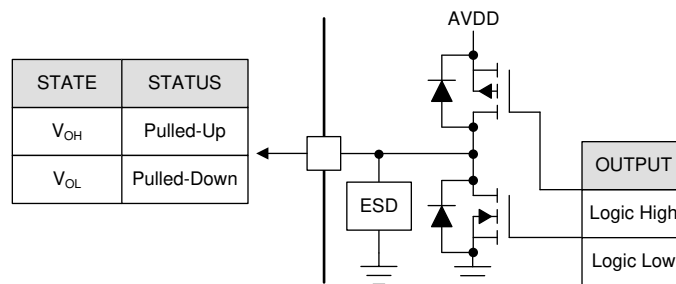

Figure 8-26. Push Pull

8.3.10.5 Four Level Input Pin

Figure 8-27 shows the structure of the four level input pins, SLEW and VSEL_BK on hardware interface devices. The input can be set with an external resistor.

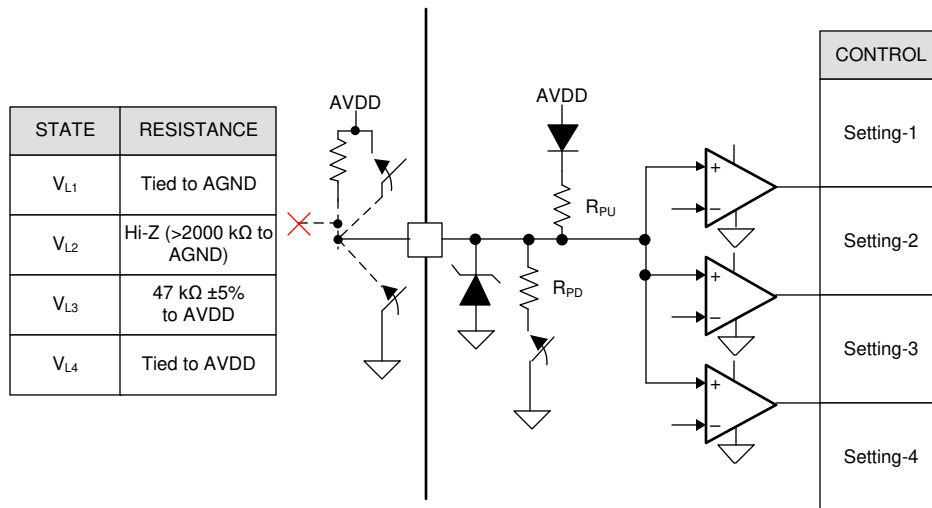

Figure 8-27. Four Level Input Pin Structure

8.3.10.6 Seven Level Input Pin

Figure 8-28 shows the structure of the seven level input pins, ADVANCE and MODE, on hardware interface devices. The input can be set with an external resistor.

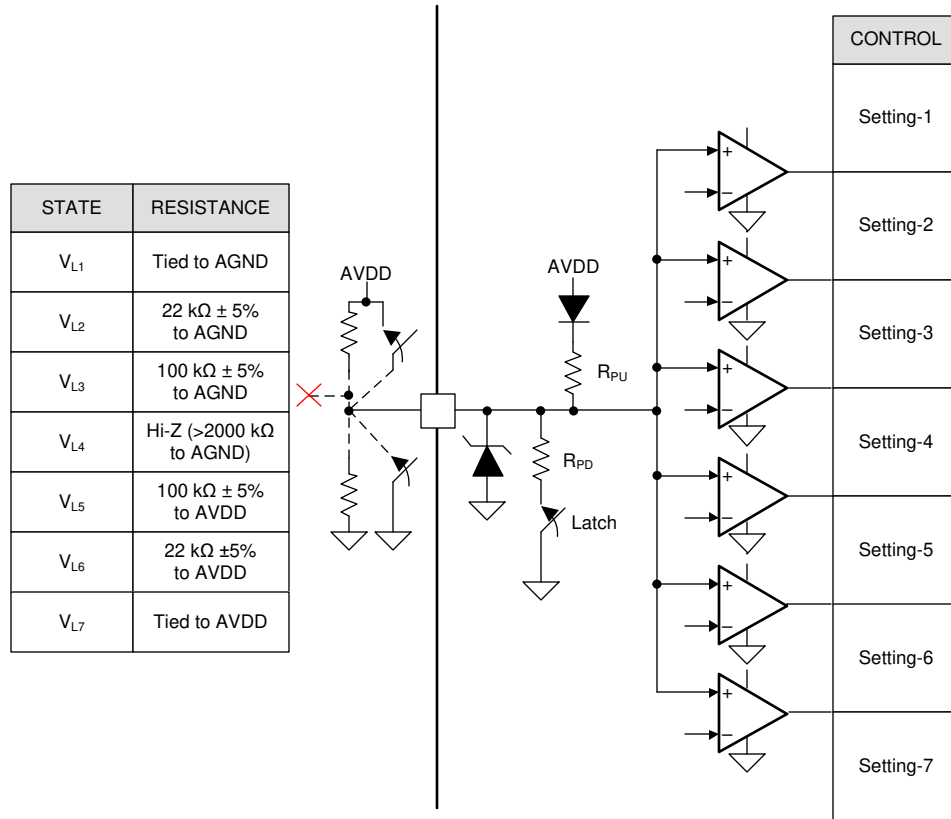

Figure 8-28. Seven Level Input Pin Structure

8.3.11 Active Demagnetization

MCT8316Z family of devices has smart rectification features (active demagnetization) which decreases power losses in the device by reducing diode conduction losses. When this feature is enabled, the device automatically turns ON the corresponding MOSFET whenever it detects diode conduction. This feature can be configured with the MODE pins in hardware variants. In SPI device variants this can be configured through EN_ASR and EN_AAR bits. The smart rectification is classified into two categories of automatic synchronous rectification (ASR) mode and automatic asynchronous rectification (AAR) mode which are described in sections below.

Note

In SPI device variants both bits, EN_ASR and EN_AAR needs to set to 1 to enable active demagnetization.

The MCT8316Z device includes a high-side (AD_HS) and low-side (AD_LS) comparator which detects the negative flow of current in the device on each half-bridge. The AD_HS comparator compares the sense-FET output with the supply voltage (VM) threshold, whereas the AD_LS comparator compares with the ground (0-V) threshold. Depending upon the flow of current from OUTx to VM or PGND to OUTx, the AD_HS or the AD_LS comparator trips. This comparator provides a reference point for the operation of active demagnetization feature.

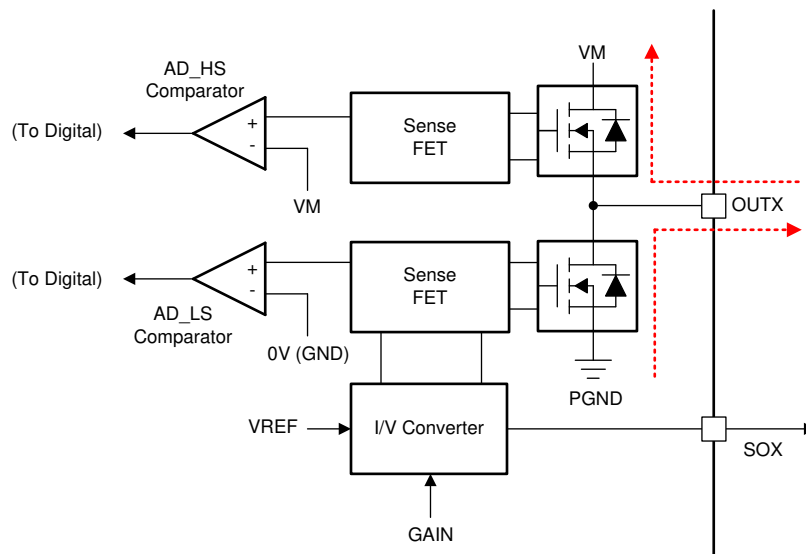

Figure 8-29. Active Demagnetization Operation

Table 8-7 shows the configuration of ASR and AAR mode in the MCT8316Z device.

Table 8-7. PWM_MODE Configuration

MODE Type	MODE Pin (Hardware Variant)	ASR and AAR configuration	Hall Configuration	Modulation	ASR and AAR Mode
Mode 1	Connected to AGND	EN_ASR = 0, EN_AAR = 0	Analog Hall Input	Asynchronous	ASR and AAR Disabled
Mode 2	Connected to AGND with R _{MODE1}	EN_ASR = 0, EN_AAR = 0	Digital Hall Input	Asynchronous	ASR and AAR Disabled
Mode 3	Connected to AGND with R _{MODE2}	EN_ASR = 0, EN_AAR = 0	Analog Hall Input	Synchronous	ASR and AAR Disabled
Mode 4	Hi-Z	EN_ASR = 0, EN_AAR = 0	Digital Hall Input	Synchronous	ASR and AAR Disabled
Mode 5	Connected to AVDD with R _{MODE2}	EN_ASR = 1, EN_AAR = 1	Analog Hall Input	Synchronous	ASR and AAR Enabled

Table 8-7. PWM_MODE Configuration (continued)

MODE Type	MODE Pin (Hardware Variant)	ASR and AAR configuration	Hall Configuration	Modulation	ASR and AAR Mode
Mode 6	Connected to AVDD with R _{MODE1}	EN_ASR = 1, EN_AAR = 1	Digital Hall Input	Synchronous	ASR and AAR Enabled
Mode 7	Connected to AVDD				

8.3.11.1 Automatic Synchronous Rectification Mode (ASR Mode)

The automatic synchronous rectification (ASR) mode is divided into two categories of ASR during commutation and ASR during PWM mode.

8.3.11.1.1 Automatic Synchronous Rectification in Commutation

Figure 8-30 shows the operation of active demagnetization during the BLDC motor commutation. As shown in Figure 8-30 (a), the current is flowing from HA to LC in one commutation state. During the commutation changeover as shown in Figure 8-30 (b), the HC switch is turned on, whereas the commutation current (due to motor inductance) in OUTA flows through the body diode of LA. This incorporates a higher diode loss depending on the commutation current. This commutation loss is reduced by turning on the LA for the commutation time as shown in Figure 8-30 (c).

Similarly the operation of high-side FET is realized in Figure 8-30 (d), (e) and (f).

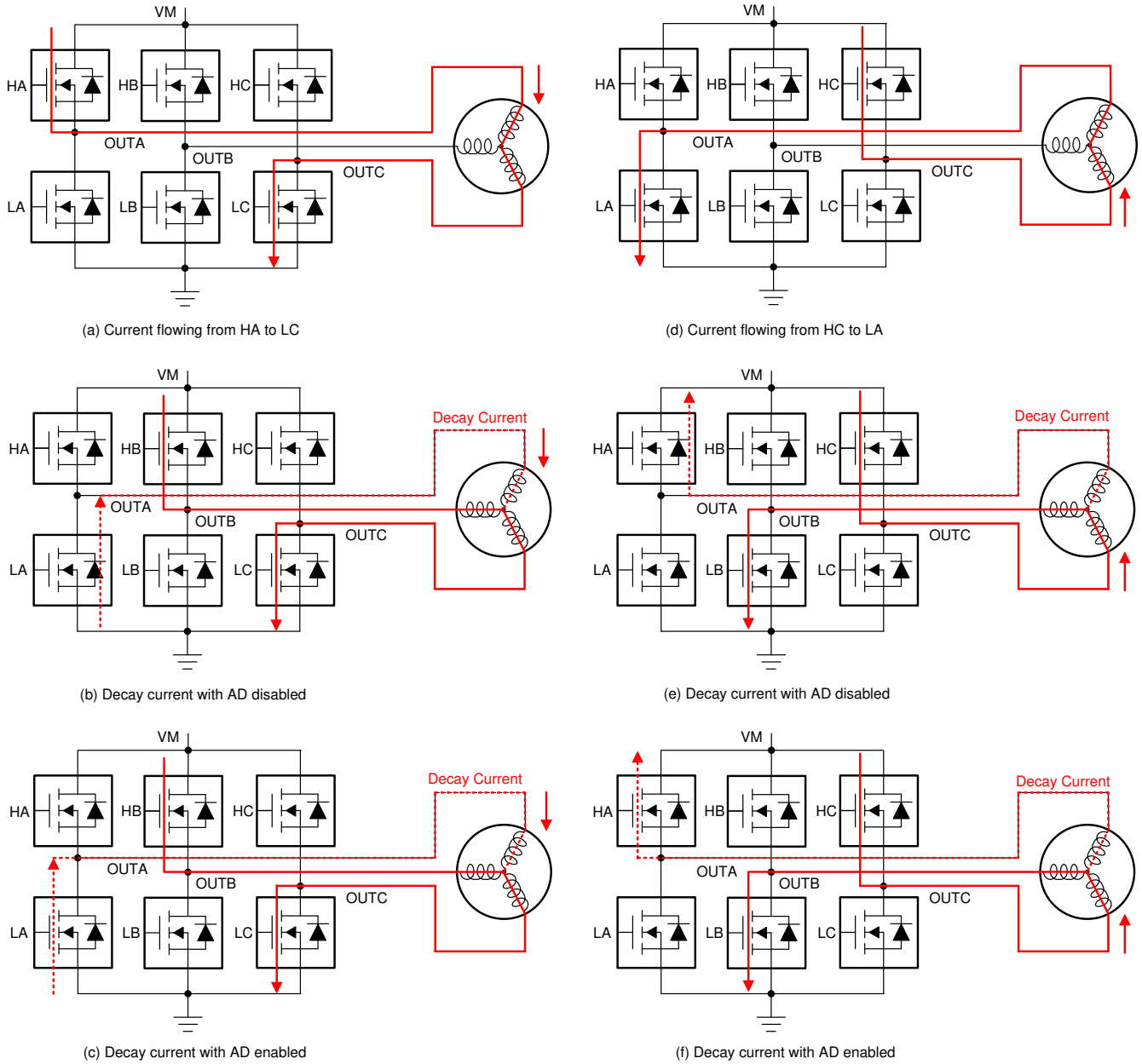

Figure 8-30. ASR in BLDC Motor Commutation

Figure 8-31 (a) shows the BLDC motor phase current waveforms for automatic synchronous rectification mode in BLDC motor operating with trapezoidal commutation. This figure shows the operation of various switches in a single commutation cycle.

Figure 8-31 (b) shows the zoomed waveform of commutation cycle with details on the ASR mode start with margin time (t_{margin}) and ASR mode early stop due to active demag. comparator threshold and delays.

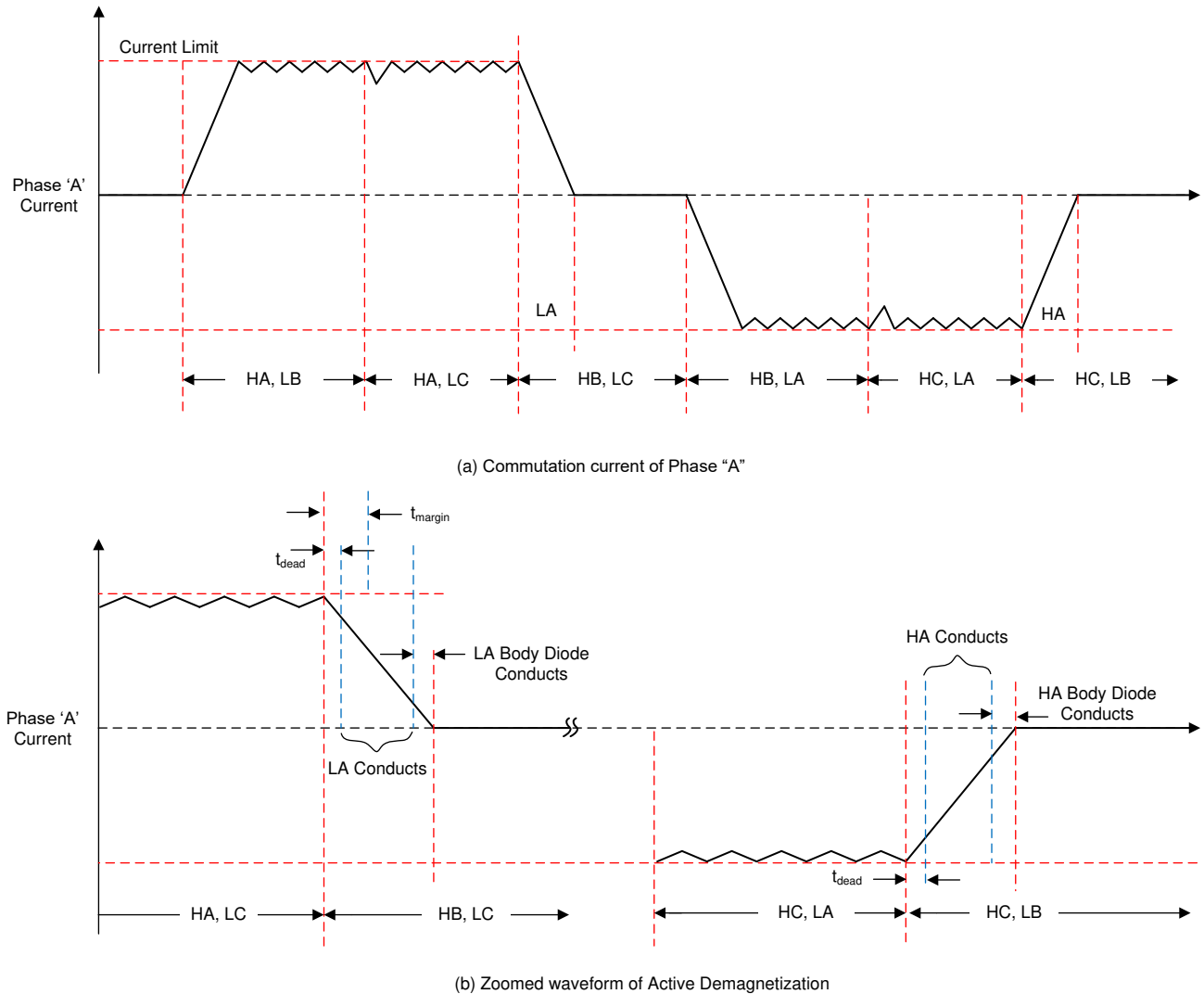

Figure 8-31. Current Waveforms for ASR in BLDC Motor Commutation

8.3.11.1.2 Automatic Synchronous Rectification in PWM Mode

Figure 8-32 shows the operation of ASR in PWM mode. As shown in this figure, a PWM is applied only on the high-side FET, whereas the low-side FET is always off. During the PWM off time, current decays from the low-side FET which results in higher power losses. Therefore, this mode supports turning on the low-side FET during the low-side diode conduction.

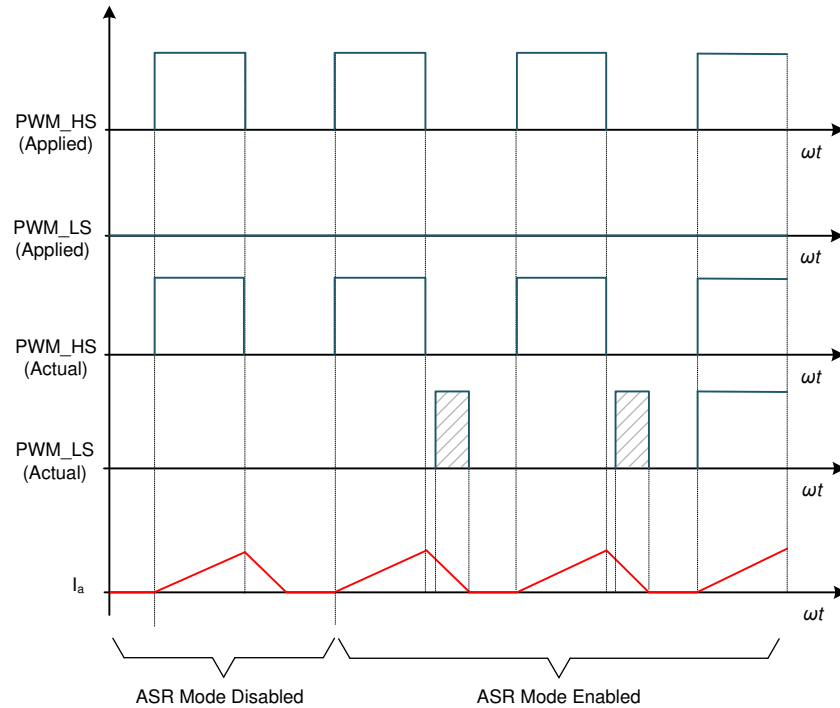

Figure 8-32. ASR in PWM Mode

8.3.11.2 Automatic Asynchronous Rectification Mode (AAR Mode)

Figure 8-33 shows the operation of AAR in PWM mode. As shown in this figure, a PWM is applied in a synchronous rectification to the high-side and low-side FETs. During the low-side FET conduction, for lower inductance motors, the current can decay to zero and becomes negative since low side FET is in on-state. This creates a negative torque on the BLDC motor operation. When AAR mode is enabled, the current during the decay is monitored and the low-side FET is turned off as soon as the current reaches near to zero. This saves the negative current building in the BLDC motor which results in better noise performance and better thermal management.

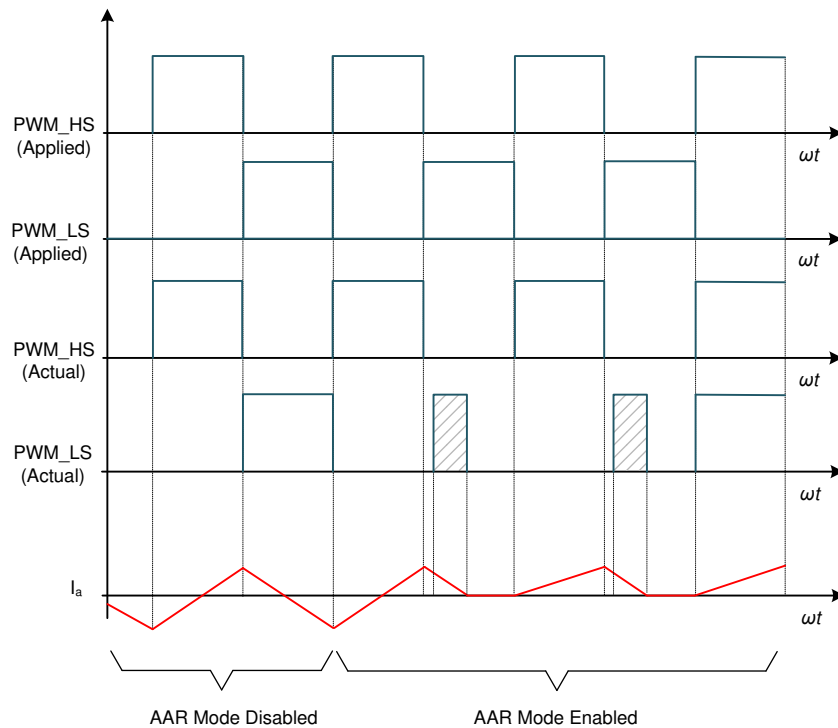

Figure 8-33. AAR in PWM Mode

8.3.12 Cycle-by-Cycle Current Limit

The current-limit circuit activates if the current flowing through the low-side MOSFET exceeds the I_{LIMIT} current. This feature restricts motor current to less than the I_{LIMIT} .

The current-limit circuitry utilizes the current sense amplifier output of the three phases compared with the voltage at ILIM pin. Figure 8-34 shows the implementation of current limit circuitry. As shown in this figure, the output of current sense amplifiers is combined with star connected resistive network. This measured voltage V_{MEAS} is compared with the external reference voltage V_{ILIM} pin to realize the current limit implementation. The relation between current sensed on OUTX pin and V_{MEAS} threshold is given as:

$$V_{MEAS} = \left(\frac{V_{AVDD}}{2} \right) - ((I_{OUTA} + I_{OUTB} + I_{OUTC}) \times GAIN/3) \quad (4)$$

where

- AVDD is 3.3-V LDO output
- OUTX is current flowing into the low-side MOSFET
- GAIN is the CSA_GAIN setting

The I_{LIMIT} threshold can be adjusted by configuring ILIM pin between $AVDD/2$ to $(AVDD/2 - 0.4)$ V. $AVDD/2$ is minimum value and when it is applied on ILIM pin cycle by cycle current limit is disabled, whereas maximum threshold of 8A can be configured by applying $(AVDD/2 - 0.4)$ V on ILIM pin.

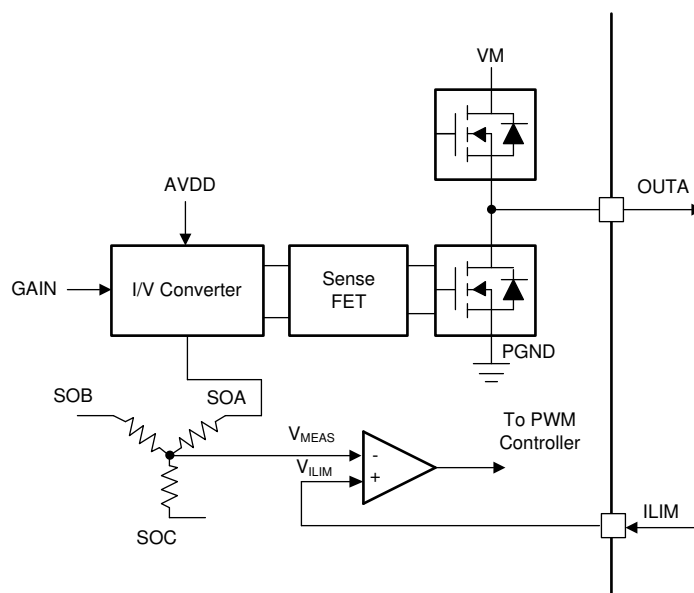

Figure 8-34. Current Limit Implementation

When then the current limit activates, the high-side FET is disabled until the beginning of the next PWM cycle as shown in Figure 8-35. The low-side FETs can operate in brake mode or high-Z mode by configuring the ILIM_RECIR bit in the SPI device variant.

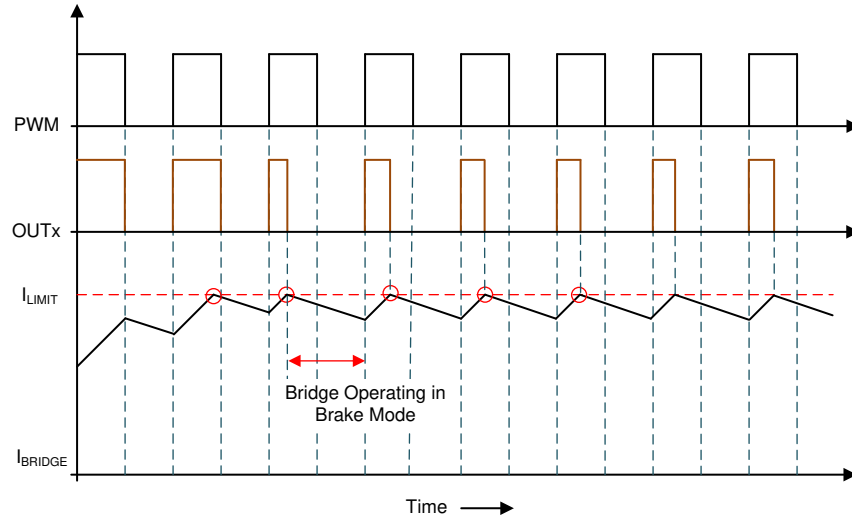

Figure 8-35. Cycle-by-Cycle Current-Limit Operation

In the MCT8316Z device, when the current limit activates in synchronous rectification mode, the current recirculates through the low-side FETs while the high-side FETs are disabled as shown in [Figure 8-36](#)

Moreover, when the current limit activates in asynchronous rectification mode, the current recirculates through the body diodes of the low-side FETs while the high-side FETs are disabled as shown in [Figure 8-37](#)

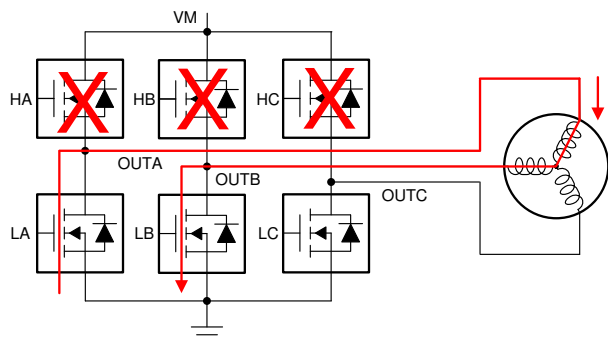

Figure 8-36. Brake State

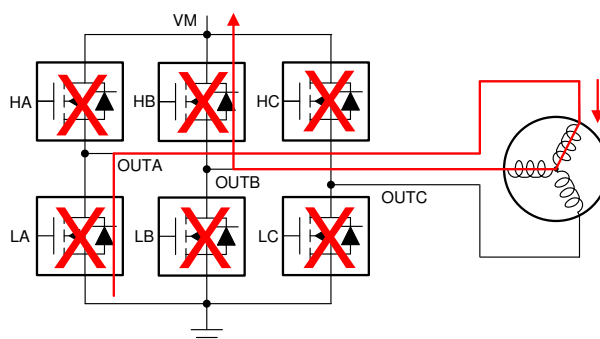

Figure 8-37. Coast State

Note

The current-limit circuit is ignored immediately after the PWM signal goes active for a short blanking time to prevent false trips of the current-limit circuit.

Note

During the brake operation, a high-current can flow through the low-side FETs which can eventually trigger the over current protection circuit. This allows the body-diode of the high-side FET to conduct and pump brake energy to the VM supply rail.

8.3.12.1 Cycle by Cycle Current Limit with 100% Duty Cycle Input

In case of 100% duty cycle applied on PWM input, there is no edge available to turn high-side FET back on. To overcome this problem, MCT8316Z has built in internal PWM clock which is used to turn high-side FET back on once it is disabled after exceeding I_{LIMIT} threshold. In SPI variant MCT8316ZR, this internal PWM clock can be configured to either 20 kHz or 40 kHz through PWM_100_DUTY_SEL. In H/W variant MCT8316ZT PWM internal clock is set to 20 kHz. Figure 8-38 shows operation with 100 % duty cycle.

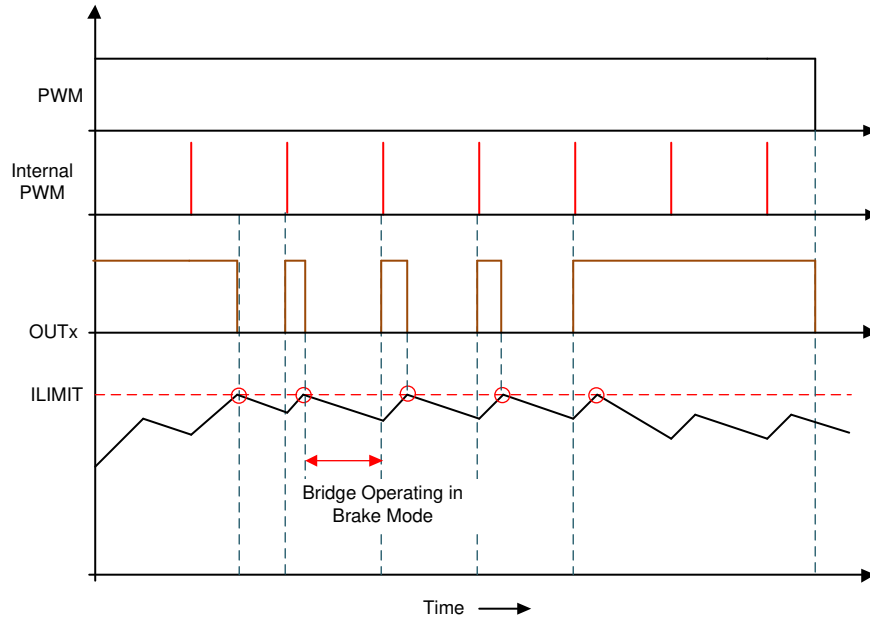

Figure 8-38. Cycle-by-Cycle Current-Limit Operation with 100% PWM Duty Cycle

8.3.13 Hall Comparators (Analog Hall Inputs)

Three comparators are provided to process the raw signals from the Hall-effect sensors to commutate the motor. The Hall comparators sense the zero crossings of the differential inputs and pass the information to digital logic. The Hall comparators have hysteresis, and their detect threshold is centered at 0. The hysteresis is defined as shown in Figure 8-39.

In addition to the hysteresis, the Hall inputs are deglitched with a circuit that ignores any extra Hall transitions for a period of t_{HDEG} after sensing a valid transition. Ignoring these transitions for the t_{HDEG} time prevents PWM noise from being coupled into the Hall inputs, which can result in erroneous commutation.

If excessive noise is still coupled into the Hall comparator inputs, adding capacitors between the positive and negative inputs of the Hall comparators may be required. The ESD protection circuitry on the Hall inputs implements a diode to the AVDD pin. Because of this diode, the voltage on the Hall inputs should not exceed the AVDD voltage.

Because the AVDD pin is disabled in sleep mode (nSLEEP inactive), the Hall inputs should not be driven by external voltages in sleep mode. If the Hall sensors are powered externally, the supply to the Hall sensors should be disabled if the MCT8316Z device is put into sleep mode. In addition, the Hall sensors' power supply should be powered up after enabling the motor otherwise an invalid Hall state may cause a delay in motor operation.

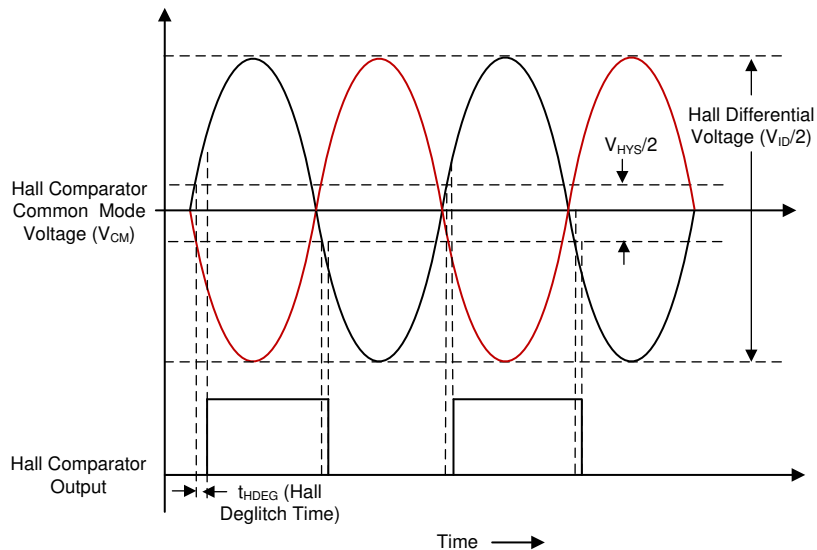

Figure 8-39. Hall Comparators Operation

8.3.14 Advance Angle

The MCT8316Z includes device an advance angle feature to advance the commutation by a specified electrical angle based on the voltage on the ADVANCE pin (in H/W device variant) or the ADVANCE bits (in SPI device variant). [Figure 8-40](#) shows the operation of advance angle feature.

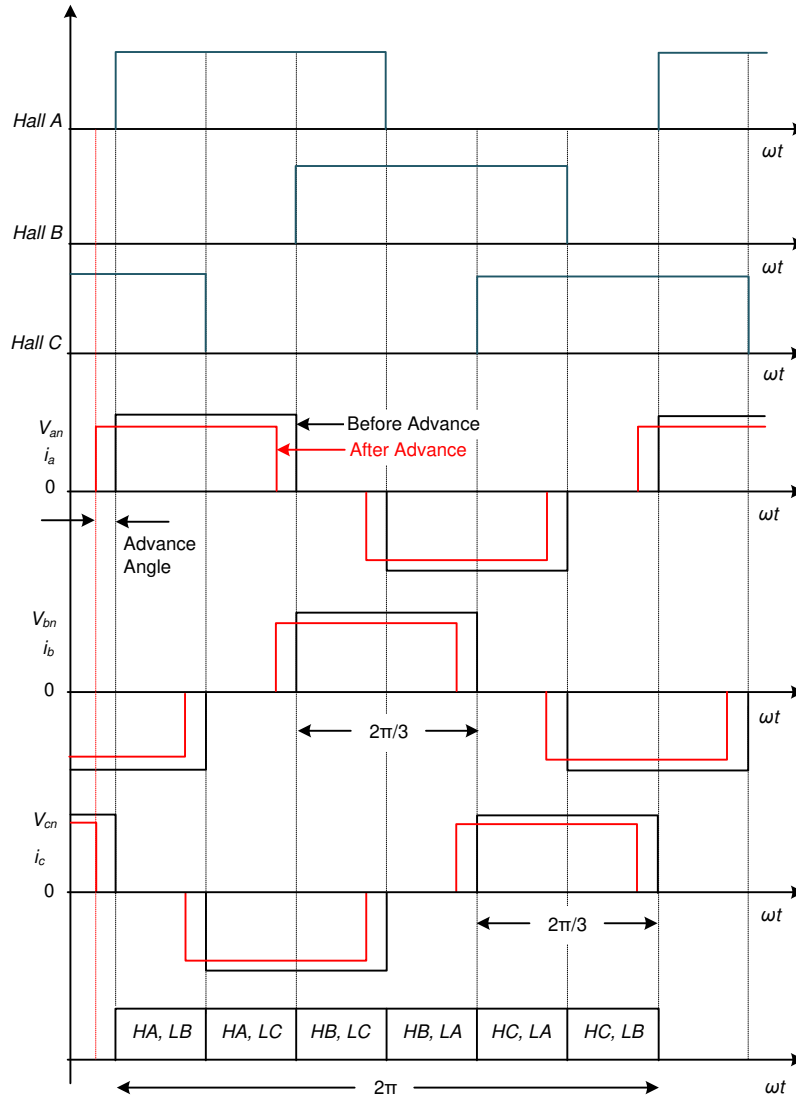

Figure 8-40. Advance Angle

8.3.15 FGOUT Signal

The MCT8316Z device also has an open-drain FGOUT signal that can be used for closed-loop speed control of a BLDC motor. This signal includes the information of all three Hall-elements inputs as shown in Section 8.3.15. In the MCT8316ZR (SPI variant), FGOUT can be configured to be a different division factor of Hall signals as shown in Section 8.3.15. In the MCT8316ZT (Hardware variant), the default mode is FGOUT_SEL = 00b.

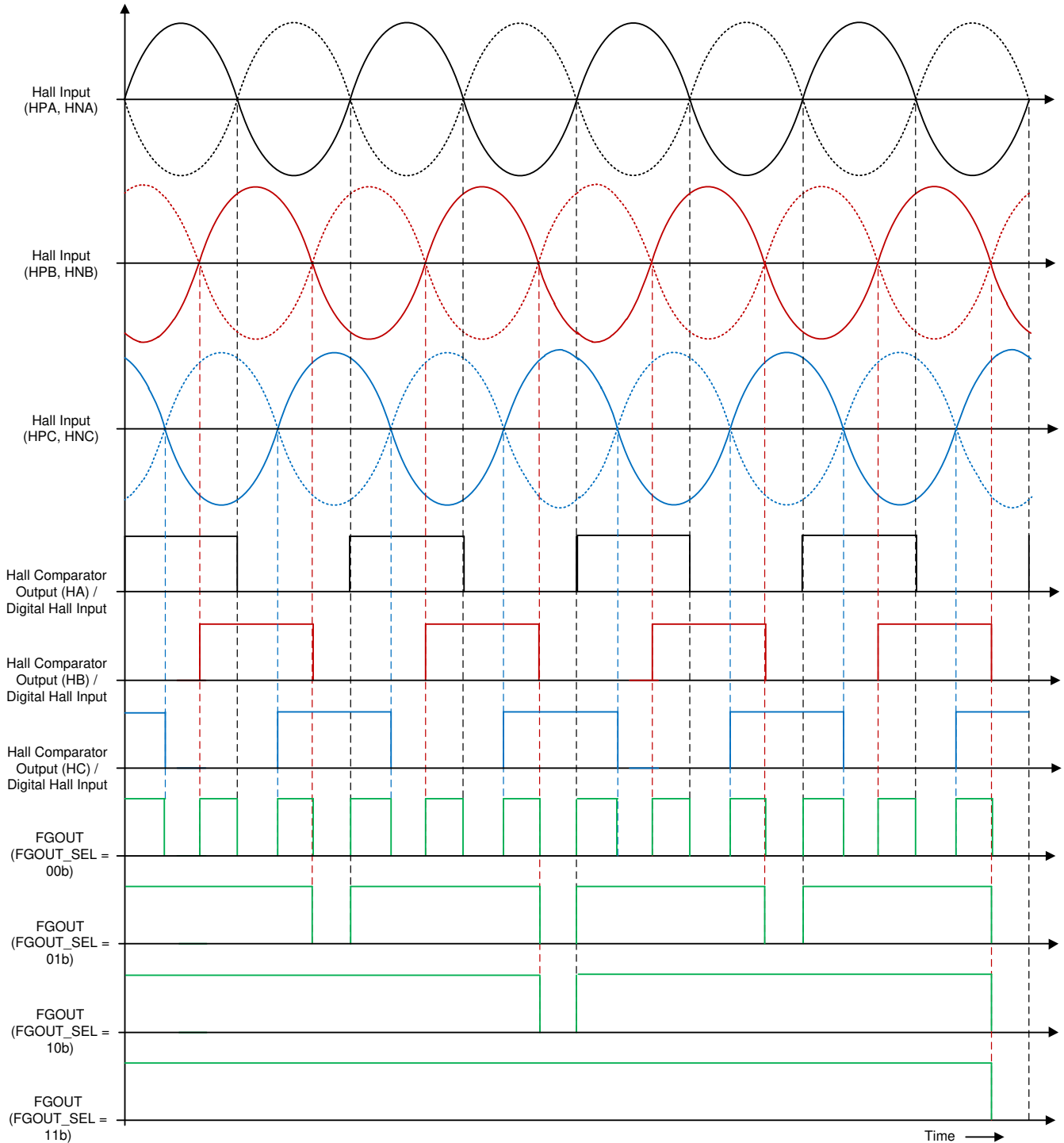

Figure 8-41. FGOUT Signal

8.3.16 Protections

The MCT8316Z family of devices is protected against VM undervoltage, charge pump undervoltage, and overcurrent events. [Table 8-8](#) summarizes various faults details.

Table 8-8. Fault Action and Response (SPI Devices)

FAULT	CONDITION	CONFIGURATION	REPORT	H-BRIDGE	LOGIC	RECOVERY
VM undervoltage (NPOR)	$V_{VM} < V_{UVLO}$	—	—	Hi-Z	Disabled	Automatic: $V_{VM} > V_{UVLO_R}$ CLR_FLT, nSLEEP Reset Pulse (NPOR bit)
AVDD undervoltage (NPOR)	$V_{AVDD} < V_{AVDD_UV}$	—	—	Hi-Z	Disabled	Automatic: $V_{AVDD} > V_{AVDD_UV_R}$ CLR_FLT, nSLEEP Reset Pulse (NPOR bit)
Buck undervoltage (BUCK_UV)	$V_{FB_BK} < V_{BK_UV}$	—	nFAULT	Active	Active	Automatic: $V_{FB_BK} > V_{BUCK_UV_R}$ CLR_FLT, nSLEEP Reset Pulse (BUCK_UV bit)
Charge pump undervoltage (VCP_UV)	$V_{CP} < V_{CPUV}$	—	nFAULT	Hi-Z	Active	Automatic: $V_{VCP} > V_{CPUV}$ CLR_FLT, nSLEEP Reset Pulse (VCP_UV bit)
OverVoltage Protection (OVP)	$V_{VM} > V_{OVP}$	OVP_EN = 0b	None	Active	Active	No action (OVP Disabled)
		OVP_EN = 1b	FAULT	Hi-Z	Active	Automatic: $V_{VM} < V_{OVP}$ CLR_FLT, nSLEEP Reset Pulse (OVP bit)
Overcurrent Protection (OCP)	$I_{PHASE} > I_{OCP}$	OCP_MODE = 00b	nFAULT	Hi-Z	Active	Latched: CLR_FLT, nSLEEP Reset Pulse (OCP bits)
		OCP_MODE = 01b	nFAULT	Hi-Z	Active	Retry: t_{RETRY}
		OCP_MODE = 10b	nFAULT	Active	Active	Automatic: CLR_FLT, nSLEEP Reset Pulse (OCP bits)
		OCP_MODE = 11b	None	Active	Active	No action
Buck Overcurrent Protection (BUCK_OCP)	$I_{BK} > I_{BK_OC}$	—	nFAULT	Active	Active	Retry: t_{RETRY}
SPI Error (SPI_FLT)	SCLK fault and ADDR fault	SPI_FLT_REP = 0b	nFAULT	Active	Active	Automatic: CLR_FLT, nSLEEP Reset Pulse (SPI_FLT bit)
		SPI_FLT_REP = 1b	None	Active	Active	No action
OTP Error (OTP_ERR)	OTP reading is erroneous	—	nFAULT	Hi-Z	Active	Latched: Power Cycle, nSLEEP Reset Pulse
Motor Lock (MTR_LOCK)	No Hall Signals > $t_{MTR_LOCK_TDET}$	MTR_LOCK_MODE = 00b	nFAULT	Hi-Z	Active	Latched: CLR_FLT, nSLEEP Pulse (MTR_LOCK bit)
		MTR_LOCK_MODE = 01b	nFAULT	Hi-Z	Active	Retry: $t_{MTR_LOCK_RETRY}$
		MTR_LOCK_MODE = 10b	nFAULT	Active	Active	Automatic: CLR_FLT, nSLEEP Reset Pulse (OCP bits)
		MTR_LOCK_MODE = 11b	None	Active	Active	No action
Thermal warning (OTW)	$T_J > T_{OTW}$	OTW_REP = 0b	None	Active	Active	No action
		OTW_REP = 1b	nFAULT	Active	Active	Automatic: $T_J < T_{OTW} - T_{HYS}$ CLR_FLT, nSLEEP Pulse (OTW bit)
Thermal shutdown (OTSD)	$T_J > T_{OTSD}$	—	nFAULT	Hi-Z	Active	Automatic: $T_J < T_{OTSD} - T_{HYS}$ CLR_FLT, nSLEEP Pulse (OTS bit)

8.3.16.1 VM Supply Undervoltage Lockout (NPOR)

If at any time the input supply voltage on the VM pin falls lower than the V_{UVLO} threshold (VM UVLO falling threshold), all of the integrated FETs, driver charge-pump and digital logic controller are disabled as shown in Figure 8-42. Normal operation resumes (driver operation) when the VM undervoltage condition is removed. The NPOR bit is reset and latched low in the IC status (IC_STAT) register once the device presumes VM. The NPOR bit remains in reset condition until cleared through the CLR_FLT bit or an nSLEEP pin reset pulse (t_{RST}).

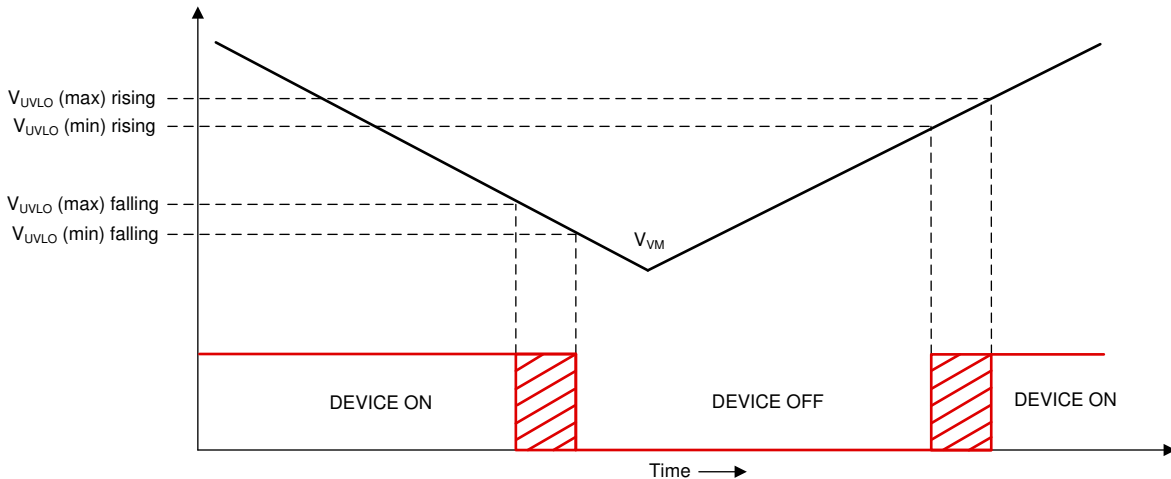

Figure 8-42. VM Supply Undervoltage Lockout

8.3.16.2 AVDD Undervoltage Lockout (AVDD_UV)

If at any time the voltage on AVDD pin falls lower than the V_{AVDD_UV} threshold, all of the integrated FETs, driver charge-pump and digital logic controller are disabled. Normal operation resumes (driver operation) when the AVDD undervoltage condition is removed. The NPOR bit is reset and latched low in the IC status (IC_STAT) register once the device presumes VM. The NPOR bit remains in reset condition until cleared through the CLR_FLT bit or an nSLEEP pin reset pulse (t_{RST}).

8.3.16.3 BUCK Undervoltage Lockout (BUCK_UV)

If at any time the voltage on VFB_BK pin falls lower than the V_{BK_UV} threshold, the integrated FETs of the buck regulator are disabled while the driver FETs, charge pump, and digital logic control continue to operate normally. The nFAULT pin is driven low in the event of a buck undervoltage fault, and the BK_FLT bit in IC_STAT register is set in SPI devices. The FAULT and BUCK_UV bits are also latched high in the registers on SPI devices. Normal operation starts again (buck regulator operation and the nFAULT pin is released) when the BUCK undervoltage condition clears. The BK_FLT and BUCK_UV bits stay set until cleared through the CLR_FLT bit or an nSLEEP pin reset pulse (t_{RST}).

8.3.16.4 VCP Charge Pump Undervoltage Lockout (CPUV)

If at any time the voltage on the VCP pin (charge pump) falls lower than the V_{CPUV} threshold voltage of the charge pump, all of the integrated FETs are disabled and the nFAULT pin is driven low. The FAULT and VCP_UV bits are also latched high in the registers on SPI devices. Normal operation starts again (driver operation and the nFAULT pin is released) when the VCP undervoltage condition clears. The CPUV bit stays set until cleared through the CLR_FLT bit or an nSLEEP pin reset pulse (t_{RST}). The CPUV protection is always enabled in both hardware and SPI device variants.

8.3.16.5 Overvoltage Protections (OV)

If at any time input supply voltage on the VM pins rises higher lower than the V_{OVP} threshold voltage, all of the integrated FETs are disabled and the nFAULT pin is driven low. The FAULT and OVP bits are also latched high in the registers on SPI devices. Normal operation starts again (driver operation and the nFAULT pin is released) when the OVP condition clears. The OVP bit stays set until cleared through the CLR_FLT bit or an nSLEEP pin

reset pulse (t_{RST}). Setting the OVP_EN bit high on the SPI devices enables this protection feature. On hardware interface devices, the OVP protection is always enabled and set to a 34-V threshold.

The OVP threshold is also programmable on the SPI device variant. The OVP threshold can be set to 20-V or 32-V based on the OVP_SEL bit.

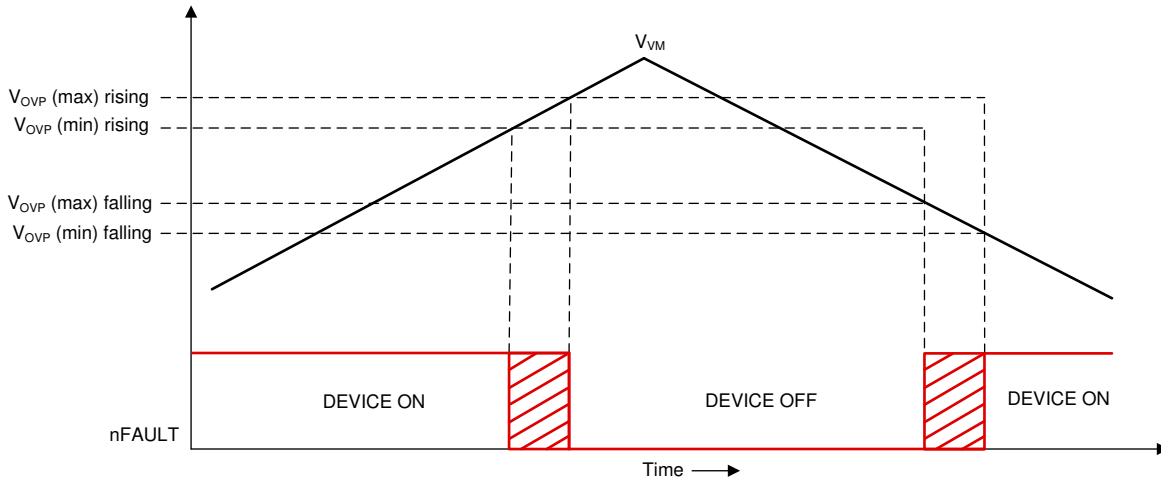

Figure 8-43. Over Voltage Protection

8.3.16.6 Overcurrent Protection (OCP)

A MOSFET overcurrent event is sensed by monitoring the current flowing through FETs. If the current across a FET exceeds the I_{OCP} threshold for longer than the t_{OCP_DEG} deglitch time, an OCP event is recognized and action is done according to the OCP_MODE bit. On hardware interface devices, the I_{OCP} threshold is fixed at 16-A threshold, the t_{OCP_DEG} is fixed at 0.6- μs , and the OCP_MODE bit is configured for latched shutdown. On SPI devices, the I_{OCP} threshold is set through the OCP_LVL SPI register, the t_{OCP_DEG} is set through the OCP_DEG SPI register, and the OCP_MODE bit can operate in four different modes: OCP latched shutdown, OCP automatic retry, OCP report only, and OCP disabled.

8.3.16.6.1 OCP Latched Shutdown (OCP_MODE = 00b)

After a OCP event in this mode, all MOSFETs are disabled and the nFAULT pin is driven low. The FAULT, OCP, and corresponding FET's OCP bits are latched high in the SPI registers. Normal operation starts again (driver operation and the nFAULT pin is released) when the OCP condition clears and a clear faults command is issued either through the CLR_FLT bit or an nSLEEP reset pulse (t_{RST}).

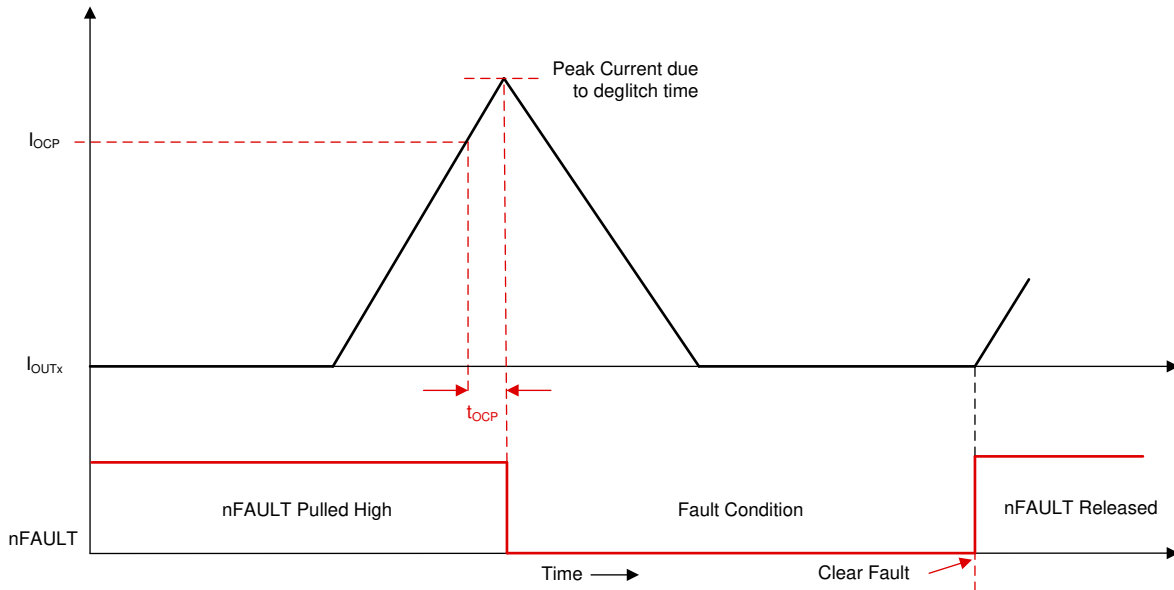

Figure 8-44. Overcurrent Protection - Latched Shutdown Mode

8.3.16.6.2 OCP Automatic Retry (OCP_MODE = 01b)

After a OCP event in this mode, all the FETs are disabled and the nFAULT pin is driven low. The FAULT, OCP, and corresponding FET's OCP bits are latched high in the SPI registers. Normal operation starts again automatically (driver operation and the nFAULT pin is released) after the t_{RETRY} time elapses. After the t_{RETRY} time elapses, the FAULT, OCP, and corresponding FET's OCP bits stay latched until a clear faults command is issued either through the CLR_FLT bit or an nSLEEP reset pulse (t_{RST}).

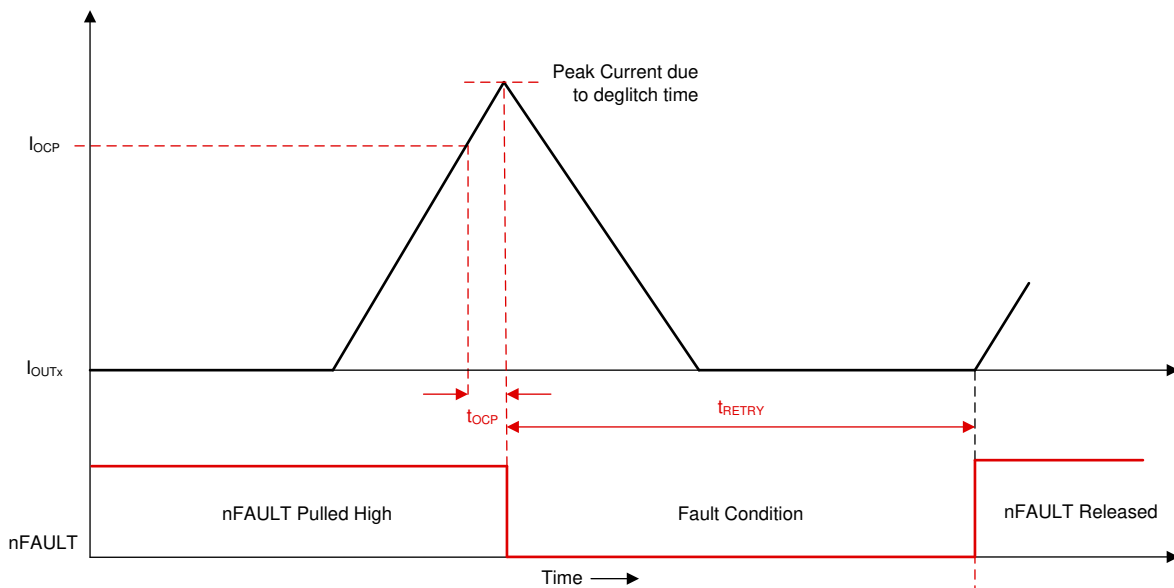

Figure 8-45. Overcurrent Protection - Automatic Retry Mode

8.3.16.6.3 OCP Report Only (OCP_MODE = 10b)

No protective action occurs after a OCP event in this mode. The overcurrent event is reported by driving the nFAULT pin low and latching the FAULT, OCP, and corresponding FET's OCP bits high in the SPI registers. The MCT8316Z continues to operate as usual. The external controller manages the overcurrent condition by acting

appropriately. The reporting clears (nFAULT pin is released) when the OCP condition clears and a clear faults command is issued either through the CLR_FLT bit or an nSLEEP reset pulse (t_{RST}).

8.3.16.6.4 OCP Disabled (OCP_MODE = 11b)

No action occurs after a OCP event in this mode.

8.3.16.7 Buck Overcurrent Protection

A buck overcurrent event is sensed by monitoring the current flowing through buck regulator's FETs. If the current across the buck regulator FET exceeds the I_{BK_OCP} threshold for longer than the t_{BK_OCP} deglitch time, an OCP event is recognized. The buck OCP mode is configured in automatic retry setting. In this setting, after a buck OCP event is detected, all the buck regulator's FETs are disabled and the nFAULT pin is driven low. The FAULT, BK_FLT, and BUCK_OCP bits are latched high in the SPI registers. Normal operation starts again automatically (driver operation and the nFAULT pin is released) after the t_{BK_RETRY} time elapses. The FAULT, BK_FLT, and BUCK_OCP bits stay latched until the t_{RETRY} period expires.

8.3.16.8 Motor Lock (MTR_LOCK)

During motor is in lock condition the hall signals will be not available, so a Motor Lock event is sensed by monitoring the hall signals. If the hall signals are not present for longer than the t_{MTR_LOCK} , a MTR_LCK event is recognized and action is done according to the MTR_LOCK_MODE bits. On hardware interface devices, the t_{MTR_LOCK} threshold is set to 1000-ms, and the MTR_LOCK_MODE bit is configured for latched shutdown. On SPI devices, the t_{MTR_LOCK} threshold is set through the MTR_LOCK_TDET register and the MTR_LOCK_MODE bit can operate in four different modes: MTR_LOCK latched shutdown, MTR_LOCK automatic retry, MTR_LOCK report only, and MTR_LOCK disabled.

8.3.16.8.1 MTR_LOCK Latched Shutdown (MTR_LOCK_MODE = 00b)

After a motor lock event in this mode, all FETs are disabled and the nFAULT pin is driven low. The FAULT and MTR_LOCK bits are latched high in the SPI registers. Normal operation starts again (driver operation and the nFAULT pin is released) when a clear faults command is issued either through the CLR_FLT bit or an nSLEEP reset pulse (t_{RST}).

8.3.16.8.2 MTR_LOCK Automatic Retry (MTR_LOCK_MODE = 01b)

After a motor lock event in this mode, all the external MOSFETs are disabled and the nFAULT pin is driven low. The FAULT and MTR_LOCK bits are latched high in the SPI registers. Normal operation starts again automatically (driver operation and the nFAULT pin is released) after the $t_{MTR_LOCK_RETRY}$ time elapses. The FAULT and MTR_LOCK bits stay latched until the $t_{MTR_LOCK_RETRY}$ period expires.

8.3.16.8.3 MTR_LOCK Report Only (MTR_LOCK_MODE= 10b)

No protective action occurs after a MTR_LOCK event in this mode. The motor lock event is reported by driving the nFAULT pin low and latching the FAULT and MTR_LOCK bits high in the SPI registers. The MCT8316Z continues to operate as usual. The external controller manages the motor lock condition by acting appropriately. The reporting clears (nFAULT pin is released) when a clear faults command is issued either through the CLR_FLT bit or an nSLEEP reset pulse (t_{RST}).

8.3.16.8.4 MTR_LOCK Disabled (MTR_LOCK_MODE = 11b)

No action occurs after a MTR_LOCK event in this mode.

8.3.16.8.5

Note

The motor lock detection scheme requires the PWM off-time (t_{PWM_OFF}) to be lower than the motor lock detection time (t_{MTR_LOCK})

8.3.16.9 Thermal Warning (OTW)

If the die temperature exceeds the trip point of the thermal warning (T_{OTW}), the OT bit in the IC status (IC_STAT) register and OTW bit in the status register is set. The reporting of OTW on the nFAULT pin can be enabled by

setting the over-temperature warning reporting (OTW_REP) bit in the configuration control register. The device performs no additional action and continues to function. In this case, the nFAULT pin releases when the die temperature decreases below the hysteresis point of the thermal warning (T_{OTW_HYS}). The OTW bit remains set until cleared through the CLR_FLT bit or an nSLEEP reset pulse (t_{RST}) and the die temperature is lower than thermal warning trip (T_{OTW}).

Note

Over temperature warning is not reported on nFAULT pin by default.

8.3.16.10 Thermal Shutdown (OTS)

If the die temperature exceeds the trip point of the thermal shutdown limit (T_{OTS}), all the FETs are disabled, the charge pump is shut down, and the nFAULT pin is driven low. In addition, the FAULT and OT bit in the IC status (IC_STAT) register and OTS bit in the status register is set. Normal operation starts again (driver operation and the nFAULT pin is released) when the overtemperature condition clears. The OTS bit stays latched high indicating that a thermal event occurred until a clear fault command is issued either through the CLR_FLT bit or an nSLEEP reset pulse (t_{RST}). This protection feature cannot be disabled.

8.4 Device Functional Modes

8.4.1 Functional Modes

8.4.1.1 Sleep Mode

The nSLEEP pin manages the state of the MCT8316Z family of devices. When the nSLEEP pin is low, the device goes to a low-power sleep mode. In sleep mode, all FETs are disabled, sense amplifiers are disabled, buck regulator (if present) is disabled, the charge pump is disabled, the AVDD regulator is disabled, and the SPI bus is disabled. The t_{SLEEP} time must elapse after a falling edge on the nSLEEP pin before the device goes to sleep mode. The device comes out of sleep mode automatically if the nSLEEP pin is pulled high. The t_{WAKE} time must elapse before the device is ready for inputs.

In sleep mode and when $V_{\text{VM}} < V_{\text{UVLO}}$, all MOSFETs are disabled.

Note

During power up and power down of the device through the nSLEEP pin, the nFAULT pin is held low as the internal regulators are enabled or disabled. After the regulators have enabled or disabled, the nFAULT pin is automatically released. The duration that the nFAULT pin is low does not exceed the t_{SLEEP} or t_{WAKE} time.

Note

TI recommends to connect pull up on nFAULT even if it is not used to avoid undesirable entry into internal test mode. If external supply is used to pull up nFAULT, ensure that it is pulled to $>2.2\text{V}$ on power up or the device will enter internal test mode.

8.4.1.2 Operating Mode

When the nSLEEP pin is high and the V_{VM} voltage is greater than the V_{UVLO} voltage, the device goes to operating mode. The t_{WAKE} time must elapse before the device is ready for inputs. In this mode the charge pump, AVDD regulator, buck regulator, and SPI bus are active.

8.4.1.3 Fault Reset (CLR_FLT or nSLEEP Reset Pulse)

In the case of device latched faults, the MCT8316Z family of devices goes to a partial shutdown state to help protect the power MOSFETs and system.

When the fault condition clears, the device can go to the operating state again by either setting the CLR_FLT SPI bit on SPI devices or issuing a reset pulse to the nSLEEP pin on either interface variant. The nSLEEP reset pulse (t_{RST}) consists of a high-to-low-to-high transition on the nSLEEP pin. The low period of the sequence should fall with the t_{RST} time window or else the device will start the complete shutdown sequence. The reset pulse has no effect on any of the regulators, device settings, or other functional blocks.

8.4.2 DRVOFF functionality

When DRVOFF pin is pulled high, all six MOSFETs are disabled. If nSLEEP is high when the DRVOFF pin is high, the charge pump, AVDD regulator, buck regulator, and SPI bus are active and any driver-related faults such as OCP will be inactive. DRVOFF pin independently disables MOSFETs which will stop motor commutation irrespective of status of PWM input pin.

Note

Since DRVOFF pin independently disables MOSFET, it can trigger fault condition resulting in nFAULT getting pulled low.

8.5 SPI Communication

8.5.1 Programming

On MCT8316Z SPI devices, an SPI bus is used to set device configurations, operating parameters, and read out diagnostic information. The SPI operates in secondary mode and connects to a controller. The SPI input data (SDI) word consists of a 16-bit word, with a 6-bit address and 8 bits of data. The SPI output consists of 16 bit word, with a 8 bits of status information (STAT register) and 8-bit register data.

A valid frame must meet the following conditions:

- The SCLK pin should be low when the nSCS pin transitions from high to low and from low to high.
- The nSCS pin should be pulled high for at least 400 ns between words.
- When the nSCS pin is pulled high, any signals at the SCLK and SDI pins are ignored and the SDO pin is placed in the Hi-Z state.
- Data is captured on the falling edge of the SCLK pin and data is propagated on the rising edge of the SCLK pin.
- The most significant bit (MSB) is shifted in and out first.
- A full 16 SCLK cycles must occur for transaction to be valid.
- If the data word sent to the SDI pin is less than or more than 16 bits, a frame error occurs and the data word is ignored.
- For a write command, the existing data in the register being written to is shifted out on the SDO pin following the 8-bit status data.

The SPI registers are reset to the default settings on power up and when the device is enters sleep mode

8.5.1.1 SPI Format

The SDI input data word is 16 bits long and consists of the following format:

- 1 read or write bit, W (bit B15)
- 6 address bits, A (bits B14 through B9)
- Parity bit, P (bit B8). Parity bit is set such that the SDI input data word has even number of 1s and 0s
- 8 data bits, D (bits B7 through B0)

The SDO output data word is 16 bits long and the first 8 bits are status bits. The data word is the content of the register being accessed.

For a write command ($W0 = 0$), the response word on the SDO pin is the data currently in the register being written to.

For a read command ($W0 = 1$), the response word is the data currently in the register being read.

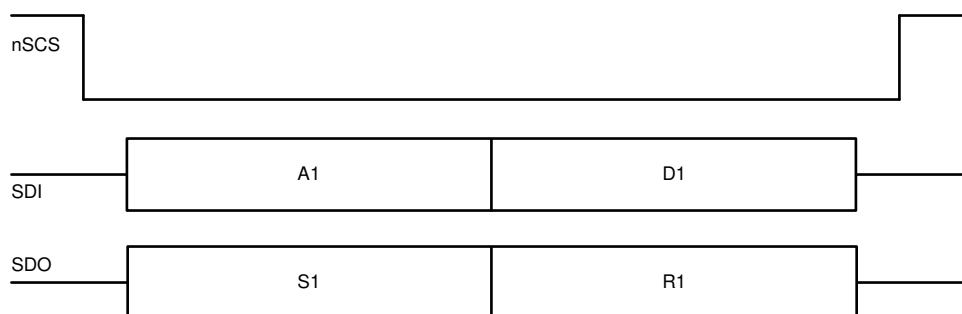

Figure 8-46.

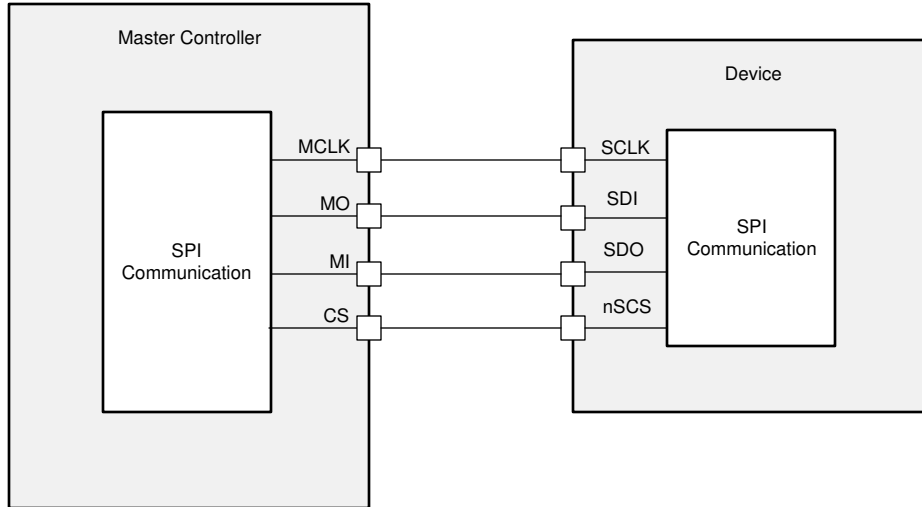

Figure 8-47.

Table 8-9. SDI Input Data Word Format

R/W	ADDRESS						Parity	DATA							
B15	B14	B13	B12	B11	B10	B9	B8	B7	B6	B5	B4	B3	B2	B1	B0
W0	A5	A4	A3	A2	A1	A0	P	D7	D6	D5	D4	D3	D2	D1	D0

Table 8-10. SDO Output Data Word Format

STATUS								DATA							
B15	B14	B13	B12	B11	B10	B9	B8	B7	B6	B5	B4	B3	B2	B1	B0
S7	S6	S5	S4	S3	S2	S1	S0	D7	D6	D5	D4	D3	D2	D1	D0

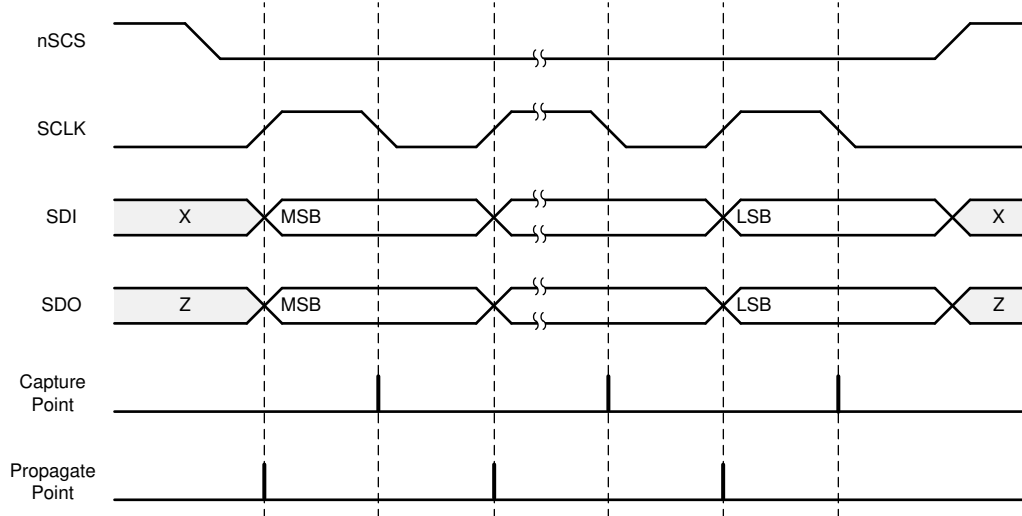

Figure 8-48. SPI Secondary Timing Diagram

SPI Error Handling

SPI Frame Error (SPI_SCLK_FLT): If the nSCS gets deasserted before the end of 16-bit frame, SPI frame error is detected and SPI_SCLK_FLT bit is set in STAT2. The SPI_SCLK_FLT status bit is latched and can be cleared when a clear faults command is issued either through the CLR_FLT bit or an nSLEEP reset pulse

SPI Address Error (SPI_ADDR_FLT): If an invalid address is provided in the ADDR field of the input SPI data on SDI, SPI address error is detected and SPI_ADDR_FLT bit in STAT2 is set. Invalid address is any

address that is not defined in [Register Map](#) i.e. address not falling in the range of address 0x0 to 0xC. The SPI_ADDR_FLT status bit is latched and can be cleared when a clear faults command is issued either through the CLR_FLT bit or an nSLEEP reset pulse

8.6 Register Map

8.6.1 STATUS Registers

[STATUS Registers](#) lists the memory-mapped registers for the STATUS registers. All register offset addresses not listed in [STATUS Registers](#) should be considered as reserved locations and the register contents should not be modified.

Table 8-11. STATUS Registers

Offset	Acronym	Register Name	Section
0h	IC_Status_Register	IC Status Register	Section 8.6.1.1
1h	Status_Register_1	Status Register 1	Section 8.6.1.2
2h	Status_Register_2	Status Register 2	Section 8.6.1.3

Complex bit access types are encoded to fit into small table cells. [STATUS Access Type Codes](#) shows the codes that are used for access types in this section.

Table 8-12. STATUS Access Type Codes

Access Type	Code	Description
Read Type		
R	R	Read
R-0	R-0	Read Returns 0s
Reset or Default Value		
-n		Value after reset or the default value

8.6.1.1 IC_Status_Register Register (Offset = 0h) [Reset = 00h]

IC_Status_Register is shown in [IC_Status_Register Register](#) and described in [IC_Status_Register Register Field Descriptions](#).

Return to the [STATUS Registers](#).

Figure 8-49. IC_Status_Register Register

7	6	5	4	3	2	1	0
MTR_LOCK	BK_FLT	SPI_FLT	OCP	NPOR	OVP	OT	FAULT
R-0h	R-0h	R-0h	R-0h	R-0h	R-0h	R-0h	R-0h

Table 8-13. IC_Status_Register Register Field Descriptions

Bit	Field	Type	Reset	Description
7	MTR_LOCK	R	0h	Motor Lock Status Bit 0h = No motor lock is detected 1h = Motor lock is detected
6	BK_FLT	R	0h	Buck Fault Bit 0h = No buck regulator fault condition is detected 1h = Buck regulator fault condition is detected
5	SPI_FLT	R	0h	SPI Fault Bit 0h = No SPI fault condition is detected 1h = SPI Fault condition is detected
4	OCP	R	0h	Over Current Protection Status Bit 0h = No overcurrent condition is detected 1h = Overcurrent condition is detected
3	NPOR	R	0h	Supply Power On Reset Bit 0h = Power on reset condition is detected on VM 1h = No power-on-reset condition is detected on VM
2	OVP	R	0h	Supply Overvoltage Protection Status Bit 0h = No overvoltage condition is detected on VM 1h = Overvoltage condition is detected on VM
1	OT	R	0h	Overtemperature Fault Status Bit 0h = No overtemperature warning / shutdown is detected 1h = Overtemperature warning / shutdown is detected
0	FAULT	R	0h	Device Fault Bit 0h = No fault condition is detected 1h = Fault condition is detected

8.6.1.2 Status_Register_1 Register (Offset = 1h) [Reset = 00h]

Status_Register_1 is shown in [Status_Register_1 Register](#) and described in [Status_Register_1 Register Field Descriptions](#).

Return to the [STATUS Registers](#).

Figure 8-50. Status_Register_1 Register

7	6	5	4	3	2	1	0
OTW	OTS	OCP_HC	OCL_LC	OCP_HB	OCP_LB	OCP_HA	OCP_LA
R-0h	R-0h	R-0h	R-0h	R-0h	R-0h	R-0h	R-0h

Table 8-14. Status_Register_1 Register Field Descriptions

Bit	Field	Type	Reset	Description
7	OTW	R	0h	Overtemperature Warning Status Bit 0h = No overtemperature warning is detected 1h = Overtemperature warning is detected
6	OTS	R	0h	Overtemperature Shutdown Status Bit 0h = No overtemperature shutdown is detected 1h = Overtemperature shutdown is detected
5	OCP_HC	R	0h	Overcurrent Status on High-side switch of OUTC 0h = No overcurrent detected on high-side switch of OUTC 1h = Overcurrent detected on high-side switch of OUTC
4	OCL_LC	R	0h	Overcurrent Status on Low-side switch of OUTC 0h = No overcurrent detected on low-side switch of OUTC 1h = Overcurrent detected on low-side switch of OUTC
3	OCP_HB	R	0h	Overcurrent Status on High-side switch of OUTB 0h = No overcurrent detected on high-side switch of OUTB 1h = Overcurrent detected on high-side switch of OUTB
2	OCP_LB	R	0h	Overcurrent Status on Low-side switch of OUTB 0h = No overcurrent detected on low-side switch of OUTB 1h = Overcurrent detected on low-side switch of OUTB
1	OCP_HA	R	0h	Overcurrent Status on High-side switch of OUTA 0h = No overcurrent detected on high-side switch of OUTA 1h = Overcurrent detected on high-side switch of OUTA
0	OCP_LA	R	0h	Overcurrent Status on Low-side switch of OUTA 0h = No overcurrent detected on low-side switch of OUTA 1h = Overcurrent detected on low-side switch of OUTA

8.6.1.3 Status_Register_2 Register (Offset = 2h) [Reset = 00h]

Status_Register_2 is shown in [Status_Register_2 Register](#) and described in [Status_Register_2 Register Field Descriptions](#).

Return to the [STATUS Registers](#).

Figure 8-51. Status_Register_2 Register

7	6	5	4	3	2	1	0
RESERVED	OTP_ERR	BUCK_OCP	BUCK_UV	VCP_UV	SPI_PARITY	SPI_SCLK_FLT	SPI_ADDR_FLT
R-0-0h	R-0h	R-0h	R-0h	R-0h	R-0-0h	R-0h	R-0h

Table 8-15. Status_Register_2 Register Field Descriptions

Bit	Field	Type	Reset	Description
7	RESERVED	R-0	0h	Reserved
6	OTP_ERR	R	0h	One Time Programmability Error 0h = No OTP error is detected 1h = OTP Error is detected
5	BUCK_OCP	R	0h	Buck Regulator Overcurrent Status Bit 0h = No buck regulator overcurrent is detected 1h = Buck regulator overcurrent is detected
4	BUCK_UV	R	0h	Buck Regulator Undervoltage Status Bit 0h = No buck regulator undervoltage is detected 1h = Buck regulator undervoltage is detected
3	VCP_UV	R	0h	Charge Pump Undervoltage Status Bit 0h = No charge pump undervoltage is detected 1h = Charge pump undervoltage is detected
2	SPI_PARITY	R-0	0h	SPI Parity Error Bit 0h = No SPI parity error is detected 1h = SPI parity error is detected
1	SPI_SCLK_FLT	R	0h	SPI Clock Framing Error Bit 0h = No SPI clock framing error is detected 1h = SPI clock framing error is detected
0	SPI_ADDR_FLT	R	0h	SPI Address Error Bit 0h = No SPI address fault is detected (due to accessing non-user register) 1h = SPI address fault is detected

8.6.2 CONTROL Registers

[CONTROL Registers](#) lists the memory-mapped registers for the CONTROL registers. All register offset addresses not listed in [CONTROL Registers](#) should be considered as reserved locations and the register contents should not be modified.

Table 8-16. CONTROL Registers

Offset	Acronym	Register Name	Section
3h	Control_Register_1	Control Register 1	Section 8.6.2.1
4h	Control_Register_2A	Control Register 2A	Section 8.6.2.2
5h	Control_Register_3	Control Register 3	Section 8.6.2.3
6h	Control_Register_4	Control Register 4	Section 8.6.2.4
7h	Control_Register_5	Control Register 5	Section 8.6.2.5
8h	Control_Register_6	Control Register 6	Section 8.6.2.6
9h	Control_Register_7	Control Register 7	Section 8.6.2.7

Table 8-16. CONTROL Registers (continued)

Offset	Acronym	Register Name	Section
Ah	Control_Register_8	Control Register 8	Section 8.6.2.8
Bh	Control_Register_9	Control Register 9	Section 8.6.2.9
Ch	Control_Register_10	Control Register 10	Section 8.6.2.10

Complex bit access types are encoded to fit into small table cells. [CONTROL Access Type Codes](#) shows the codes that are used for access types in this section.

Table 8-17. CONTROL Access Type Codes

Access Type	Code	Description
Read Type		
R	R	Read
R-0	R -0	Read Returns 0s
Write Type		
W	W	Write
W1C	W 1C	Write 1 to clear
WAPU	W APU	Write Atomic write with password unlock
Reset or Default Value		
-n		Value after reset or the default value

8.6.2.1 Control_Register_1 Register (Offset = 3h) [Reset = 00h]

Control_Register_1 is shown in [Control_Register_1 Register](#) and described in [Control_Register_1 Register Field Descriptions](#).

Return to the [CONTROL Registers](#).

Figure 8-52. Control_Register_1 Register

7	6	5	4	3	2	1	0
RESERVED					REG_LOCK		
R-0-0h					R/WAPU-0h		

Table 8-18. Control_Register_1 Register Field Descriptions

Bit	Field	Type	Reset	Description
7-3	RESERVED	R-0	0h	Reserved
2-0	REG_LOCK	R/WAPU	0h	Register Lock Bits 0h = No effect unless locked or unlocked 1h = No effect unless locked or unlocked 2h = No effect unless locked or unlocked 3h = Write 011b to this register to unlock all registers 4h = No effect unless locked or unlocked 5h = No effect unless locked or unlocked 6h = Write 110b to lock the settings by ignoring further register writes except to these bits and address 0x03h bits 2-0. 7h = No effect unless locked or unlocked

8.6.2.2 Control_Register_2A Register (Offset = 4h) [Reset = 80h]

Control_Register_2A is shown in [Control_Register_2A Register](#) and described in [Control_Register_2A Register Field Descriptions](#).

Return to the [CONTROL Registers](#).

Figure 8-53. Control_Register_2A Register

7	6	5	4	3	2	1	0
RESERVED		SDO_MODE	SLEW		PWM_MODE		CLR_FLT
R/W-2h		R/W-0h	R/W-0h		R/W-0h		W1C-0h

Table 8-19. Control_Register_2A Register Field Descriptions

Bit	Field	Type	Reset	Description
7-6	RESERVED	R/W	2h	Reserved
5	SDO_MODE	R/W	0h	SDO Mode Setting 0h = SDO IO in Open Drain Mode 1h = SDO IO in Push Pull Mode
4-3	SLEW	R/W	0h	Slew Rate Settings 0h = Slew rate is 25 V/μs 1h = Slew rate is 50 V/μs 2h = Slew rate is 125 V/μs 3h = Slew rate is 200 V/μs
2-1	PWM_MODE	R/W	0h	Device Mode Selection 0h = Asynchronous rectification with analog Hall 1h = Asynchronous rectification with digital Hall 2h = Synchronous rectification with analog Hall 3h = Synchronous rectification with digital Hall
0	CLR_FLT	W1C	0h	Clear Fault 0h = No clear fault command is issued 1h = To clear the latched fault bits. This bit automatically resets after being written.

8.6.2.3 Control_Register_3 Register (Offset = 5h) [Reset = 46h]

Control_Register_3 is shown in [Control_Register_3 Register](#) and described in [Control_Register_3 Register Field Descriptions](#).

Return to the [CONTROL Registers](#).

Figure 8-54. Control_Register_3 Register

7	6	5	4	3	2	1	0
RESERVED	RESERVED	RESERVED	PWM_100_DUTY_SEL	OVP_SEL	OVP_EN	RESERVED	OTW_REP
R-0-0h	R/W-1h	R/W-0h	R/W-0h	R/W-0h	R/W-1h	R/W-1h	R/W-0h

Table 8-20. Control_Register_3 Register Field Descriptions

Bit	Field	Type	Reset	Description
7	RESERVED	R-0	0h	Reserved
6	RESERVED	R/W	1h	Reserved
5	RESERVED	R/W	0h	Reserved
4	PWM_100_DUTY_SEL	R/W	0h	Frequency of PWM at 100% Duty Cycle 0h = 20KHz 1h = 40KHz
3	OVP_SEL	R/W	0h	Overvoltage Level Setting 0h = VM overvoltage level is 34-V 1h = VM overvoltage level is 22-V
2	OVP_EN	R/W	1h	Overvoltage Enable Bit 0h = Overvoltage protection is disabled 1h = Overvoltage protection is enabled
1	RESERVED	R/W	1h	Reserved
0	OTW_REP	R/W	0h	Overtemperature Warning Reporting Bit 0h = Over temperature reporting on nFAULT is disabled 1h = Over temperature reporting on nFAULT is enabled

8.6.2.4 Control_Register_4 Register (Offset = 6h) [Reset = 10h]

Control_Register_4 is shown in [Control_Register_4 Register](#) and described in [Control_Register_4 Register Field Descriptions](#).

Return to the [CONTROL Registers](#).

Figure 8-55. Control_Register_4 Register

7	6	5	4	3	2	1	0
DRV_OFF	OCP_CBC	OCP_DEG		OCP_RETRY	OCP_LVL	OCP_MODE	
R/W-0h	R/W-0h	R/W-1h		R/W-0h	R/W-0h	R/W-0h	

Table 8-21. Control_Register_4 Register Field Descriptions

Bit	Field	Type	Reset	Description
7	DRV_OFF	R/W	0h	Driver OFF Bit 0h = No Action 1h = Enter Low Power Standby Mode
6	OCP_CBC	R/W	0h	OCP PWM Cycle Operation Bit 0h = OCP clearing in PWM input cycle change is disabled 1h = OCP clearing in PWM input cycle change is enabled
5-4	OCP_DEG	R/W	1h	OCP Deglitch Time Settings 0h = OCP deglitch time is 0.2 μ s 1h = OCP deglitch time is 0.6 μ s 2h = OCP deglitch time is 1.25 μ s 3h = OCP deglitch time is 1.6 μ s
3	OCP_RETRY	R/W	0h	OCP Retry Time Settings 0h = OCP retry time is 5 ms 1h = OCP retry time is 500 ms
2	OCP_LVL	R/W	0h	Overcurrent Level Setting 0h = OCP level is 16 A 1h = OCP level is 24 A
1-0	OCP_MODE	R/W	0h	OCP Fault Options 0h = Overcurrent causes a latched fault 1h = Overcurrent causes an automatic retrying fault 2h = Overcurrent is report only but no action is taken 3h = Overcurrent is not reported and no action is taken

8.6.2.5 Control_Register_5 Register (Offset = 7h) [Reset = 00h]

Control_Register_5 is shown in [Control_Register_5 Register](#) and described in [Control_Register_5 Register Field Descriptions](#).

Return to the [CONTROL Registers](#).

Figure 8-56. Control_Register_5 Register

7	6	5	4	3	2	1	0
RESERVED	ILIM_RECIR	RESERVED	RESERVED	EN_AAR	EN_ASR	CSA_GAIN	
R/W-0h	R/W-0h	R/W-0h	R/W-0h	R/W-0h	R/W-0h	R/W-0h	

Table 8-22. Control_Register_5 Register Field Descriptions

Bit	Field	Type	Reset	Description
7	RESERVED	R/W	0h	Reserved
6	ILIM_RECIR	R/W	0h	Current Limit Recirculation Settings 0h = Current recirculation through FETs (Brake Mode) 1h = Current recirculation through diodes (Coast Mode)
5	RESERVED	R/W	0h	Reserved
4	RESERVED	R/W	0h	Reserved
3	EN_AAR	R/W	0h	Active Asynchronous Rectification Enable Bit 0h = AAR mode is disabled 1h = AAR mode is enabled
2	EN_ASR	R/W	0h	Active Synchronous Rectification Enable Bit 0h = ASR mode is disabled 1h = ASR mode is enabled
1-0	CSA_GAIN	R/W	0h	Current Sense Amplifier's Gain Settings 0h = CSA gain is 0.15 V/A 1h = CSA gain is 0.3 V/A 2h = CSA gain is 0.6 V/A 3h = CSA gain is 1.2 V/A

8.6.2.6 Control_Register_6 Register (Offset = 8h) [Reset = 00h]

Control_Register_6 is shown in [Control_Register_6 Register](#) and described in [Control_Register_6 Register Field Descriptions](#).

Return to the [CONTROL Registers](#).

Figure 8-57. Control_Register_6 Register

7	6	5	4	3	2	1	0
RESERVED		RESERVED	BUCK_PS_DIS	BUCK_CL	BUCK_SEL		BUCK_DIS
R-0-0h		R/W-0h	R/W-0h	R/W-0h	R/W-0h		R/W-0h

Table 8-23. Control_Register_6 Register Field Descriptions

Bit	Field	Type	Reset	Description
7-6	RESERVED	R-0	0h	Reserved
5	RESERVED	R/W	0h	Reserved
4	BUCK_PS_DIS	R/W	0h	Buck Power Sequencing Disable Bit 0h = Buck power sequencing is enabled 1h = Buck power sequencing is disabled
3	BUCK_CL	R/W	0h	Buck Current Limit Setting 0h = Buck regulator current limit is set to 600 mA 1h = Buck regulator current limit is set to 150 mA
2-1	BUCK_SEL	R/W	0h	Buck Voltage Selection 0h = Buck voltage is 3.3 V 1h = Buck voltage is 5.0 V 2h = Buck voltage is 4.0 V 3h = Buck voltage is 5.7 V
0	BUCK_DIS	R/W	0h	Buck Disable Bit 0h = Buck regulator is enabled 1h = Buck regulator is disabled

8.6.2.7 Control_Register_7 Register (Offset = 9h) [Reset = 00h]

Control_Register_7 is shown in [Control_Register_7 Register](#) and described in [Control_Register_7 Register Field Descriptions](#).

Return to the [CONTROL Registers](#).

Figure 8-58. Control_Register_7 Register

7	6	5	4	3	2	1	0
RESERVED			HALL_HYS	BRAKE_MODE	COAST	BRAKE	DIR
R-0-0h			R/W-0h	R/W-0h	R/W-0h	R/W-0h	R/W-0h

Table 8-24. Control_Register_7 Register Field Descriptions

Bit	Field	Type	Reset	Description
7-5	RESERVED	R-0	0h	Reserved
4	HALL_HYS	R/W	0h	Hall Comparator Hysteresis Settings 0h = 5 mV 1h = 50 mV
3	BRAKE_MODE	R/W	0h	Brake Mode Setting 0h = Device operation is braking in brake mode 1h = Device operation is coasting in brake mode
2	COAST	R/W	0h	Coast Bit 0h = Device coast mode is disabled 1h = Device coast mode is enabled
1	BRAKE	R/W	0h	Brake Bit 0h = Device brake mode is disabled 1h = Device brake mode is enabled
0	DIR	R/W	0h	Direction Bit 0h = Motor direction is set to clockwise direction 1h = Motor direction is set to anti-clockwise direction

8.6.2.8 Control_Register_8 Register (Offset = Ah) [Reset = 00h]

Control_Register_8 is shown in [Control_Register_8 Register](#) and described in [Control_Register_8 Register Field Descriptions](#).

Return to the [CONTROL Registers](#).

Figure 8-59. Control_Register_8 Register

7	6	5	4	3	2	1	0
FGOUT_SEL		RESERVED	MTR_LOCK_RETRY	MTR_LOCK_TDET		MTR_LOCK_MODE	
R/W-0h		R-0-0h	R/W-0h	R/W-0h		R/W-0h	

Table 8-25. Control_Register_8 Register Field Descriptions

Bit	Field	Type	Reset	Description
7-6	FGOUT_SEL	R/W	0h	Electrical Frequency Generation Output Mode Bits 0h = FGOUT frequency is 3x commutation frequency 1h = FGOUT frequency is 1x of commutation frequency 2h = FGOUT frequency is 0.5x of commutation frequency 3h = FGOUT frequency is 0.25x of commutation frequency
5	RESERVED	R-0	0h	Reserved
4	MTR_LOCK_RETRY	R/W	0h	Motor Lock Retry Time Settings 0h = 500 ms 1h = 5000 ms
3-2	MTR_LOCK_TDET	R/W	0h	Motor Lock Detection Time Settings 0h = 300 ms 1h = 500 ms 2h = 1000 ms 3h = 5000 ms
1-0	MTR_LOCK_MODE	R/W	0h	Motor Lock Fault Options 0h = Motor lock causes a latched fault 1h = Motor lock causes an automatic retrying fault 2h = Motor lock is report only but no action is taken 3h = Motor lock is not reported and no action is taken

8.6.2.9 Control_Register_9 Register (Offset = Bh) [Reset = 00h]

Control_Register_9 is shown in [Control_Register_9 Register](#) and described in [Control_Register_9 Register Field Descriptions](#).

Return to the [CONTROL Registers](#).

Figure 8-60. Control_Register_9 Register

7	6	5	4	3	2	1	0
RESERVED					ADVANCE_LVL		
R-0-0h					R/W-0h		

Table 8-26. Control_Register_9 Register Field Descriptions

Bit	Field	Type	Reset	Description
7-3	RESERVED	R-0	0h	Reserved
2-0	ADVANCE_LVL	R/W	0h	Phase Advance Setting 0h = 0° 1h = 4° 2h = 7° 3h = 11° 4h = 15° 5h = 20° 6h = 25° 7h = 30°

8.6.2.10 Control_Register_10 Register (Offset = Ch) [Reset = 00h]

Control_Register_10 is shown in [Control_Register_10 Register](#) and described in [Control_Register_10 Register Field Descriptions](#).

Return to the [CONTROL Registers](#).

Figure 8-61. Control_Register_10 Register

7	6	5	4	3	2	1	0
RESERVED			DLYCMP_EN	DLY_TARGET			
R-0-0h			R/W-0h	R/W-0h			

Table 8-27. Control_Register_10 Register Field Descriptions

Bit	Field	Type	Reset	Description
7-5	RESERVED	R-0	0h	Reserved
4	DLYCMP_EN	R/W	0h	Driver Delay Compensation enable 0h = Disable 1h = Enable
3-0	DLY_TARGET	R/W	0h	Delay Target for Driver Delay Compensation 0h = 0 us 1h = 0.4 us 2h = 0.6 us 3h = 0.8 us 4h = 1 us 5h = 1.2 us 6h = 1.4 us 7h = 1.6 us 8h = 1.8 us 9h = 2 us Ah = 2.2 us Bh = 2.4 us Ch = 2.6 us Dh = 2.8 us Eh = 3 us Fh = 3.2 us

9 Application and Implementation

Note

Information in the following applications sections is not part of the TI component specification, and TI does not warrant its accuracy or completeness. TI's customers are responsible for determining suitability of components for their purposes, as well as validating and testing their design implementation to confirm system functionality.

9.1 Application Information

The MCT8316Z can be used to drive Brushless-DC motors. The following design procedure can be used to configure the MCT8316Z.

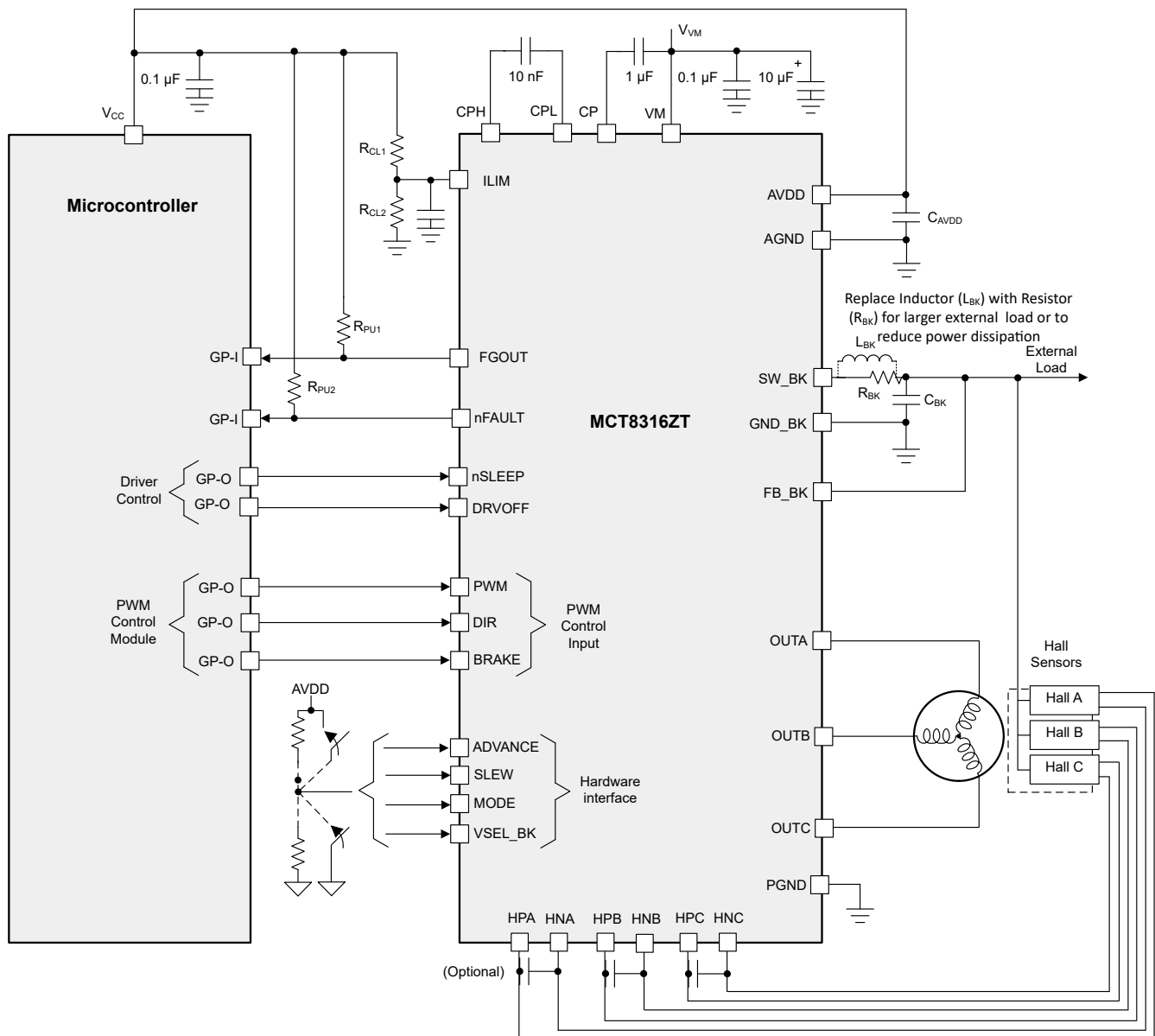

Figure 9-1. Primary Application Schematics for MCT8316ZT (hardware variant)

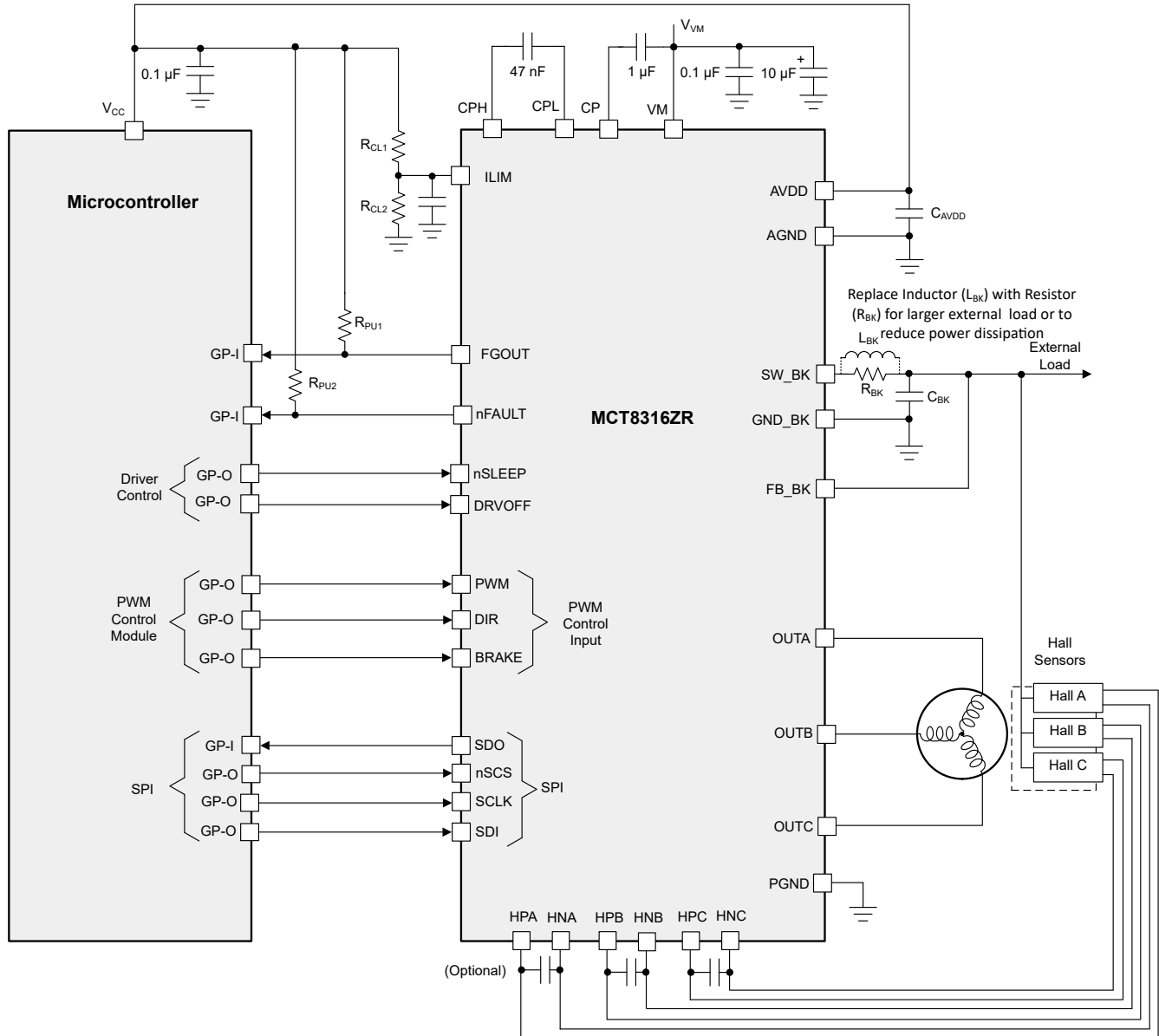

Figure 9-2. Primary Application Schematics for MCT8316ZR (SPI variant)

9.2 Hall Sensor Configuration and Connection

The combinations of Hall sensor connections in this section are common connections.

9.2.1 Typical Configuration

The Hall sensor inputs on the MCT8316Z device can interface with a variety of Hall sensors. Typically, a Hall element is used, which outputs a differential signal. To use this type of sensor, the AVDD regulator can be used to power the Hall sensor. Figure 9-3 shows the connections.

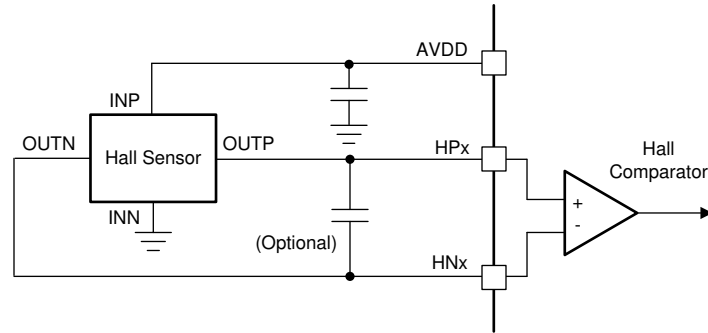

Figure 9-3. Typical Hall Sensor Configuration

Because the amplitude of the Hall-sensor output signal is very low, capacitors are often placed across the Hall inputs to help reject noise coupled from the motor. Capacitors with a value of 1 nF to 100 nF are typically used.

9.2.2 Open Drain Configuration

Some motors use digital Hall sensors with open-drain outputs. These sensors can also be used with the MCT8316Z device, with the addition of a few resistors as shown in [Figure 9-4](#).

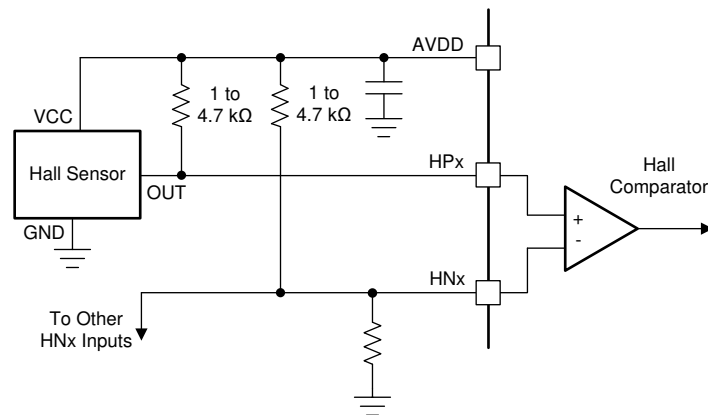

Figure 9-4. Open-Drain Hall Sensor Configuration

The negative (HNx) inputs are biased to $AVDD / 2$ by a pair of resistors between the AVDD pin and ground. For open-collector Hall sensors, an additional pullup resistor to the VREG pin is required on the positive (HPx) input. Again, the AVDD output can usually be used to supply power to the Hall sensors.

9.2.3 Series Configuration

Hall elements are also connected in series or parallel depending upon the Hall sensor current/voltage requirement. Figure 9-5 shows the series connection of Hall sensors powered via the MCT8316Z internal LDO (AVDD). This configuration is used if the current requirement per Hall sensor is high (>10 mA)

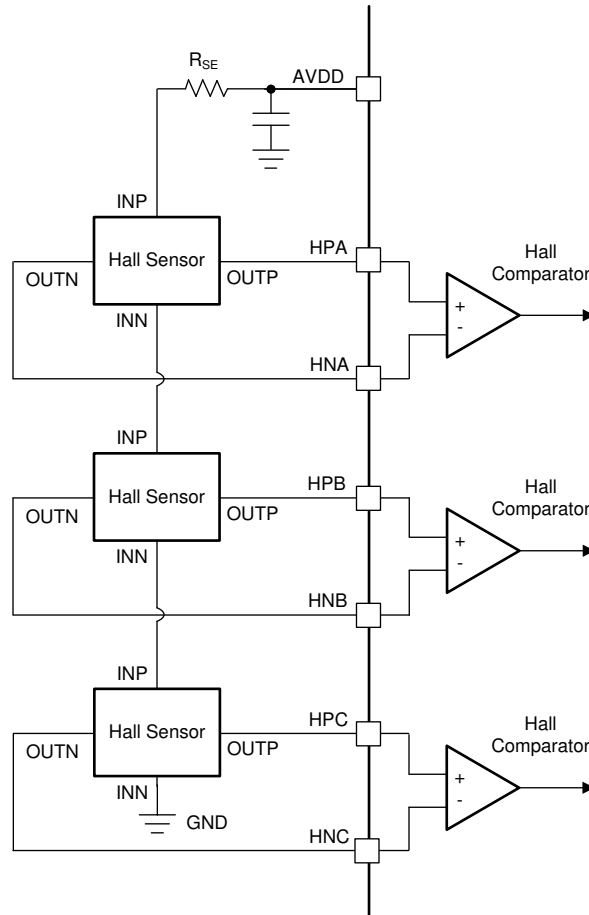

Figure 9-5. Hall Sensor Connected in Series Configuration

9.2.4 Parallel Configuration

Figure 9-6 shows the parallel connection of Hall sensors which is powered by the AVDD. This configuration can be used if the current requirement per Hall sensor is low (<10 mA).

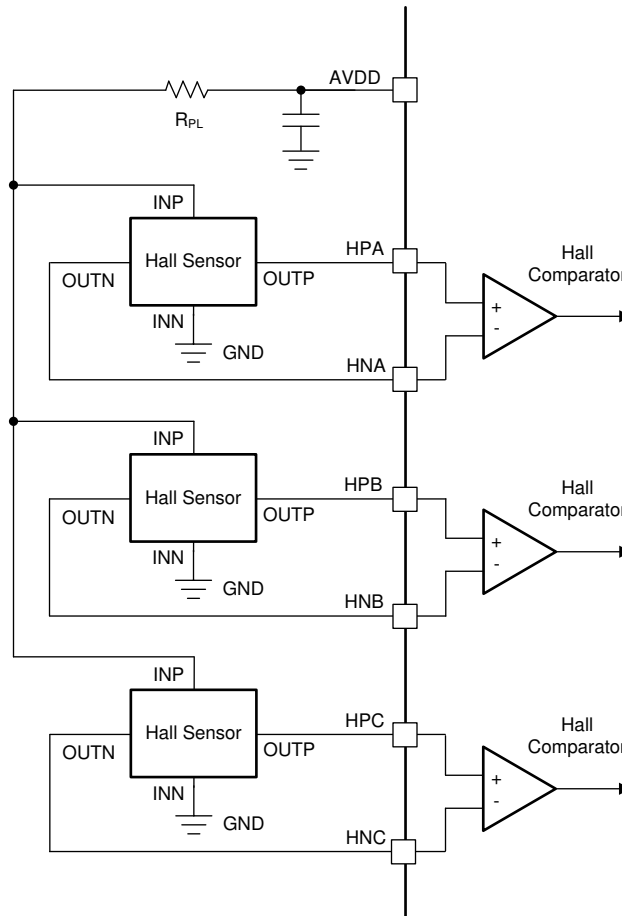

Figure 9-6. Hall Sensors Connected in Parallel Configuration

9.3 Typical Applications

9.3.1 Three-Phase Brushless-DC Motor Control With Current Limit

In this application, the MCT8316Z is used to drive a brushless-DC motor with current limit up to 100% duty cycle. The following design procedure can be used to configure the MCT8316Z in current limit mode.

9.3.1.1 Detailed Design Procedure

Table 9-1 lists the example input parameters for the system design.

Table 9-1. Design Parameters

DESIGN PARAMETERS	REFERENCE	EXAMPLE VALUE
Supply voltage	V_{VM}	24 V
Motor peak current	I_{PEAK}	2 A
PWM Frequency	f_{PWM}	50 kHz
Slew Rate Setting	SR	200 V/ μ s
Buck regulator output voltage	V_{BK}	3.3 V

9.3.1.1.1 Motor Voltage

Brushless-DC motors are typically rated for a certain voltage (for example 12 V or 24 V). Operating a motor at a higher voltage corresponds to a lower drive current to obtain the same motor power. Operating at lower voltages generally allows for more accurate control of phase currents. The MCT8316Z functions down to a supply of 4.5V. A higher operating voltage also corresponds to a higher obtainable rpm. The MCT8316Z allows for a range of possible operating voltages because of a maximum VM rating of 40 V.

9.3.1.1.2 Using Active Demagnetization

Active demagnetization reduces power losses in the device by turning on the MOSFETs automatically when the body diode starts conducting to reduce diode conduction losses. It is used in trapezoidal commutation when switching commutation states (turning a high-side MOSFET off and another high-side MOSFET on while keeping a low-side MOSFET on). Active demagnetization is enabled when EN_ASR and EN_AAR bits are set in the SPI variant or MODE pin is set to Mode 5, Mode 6, or Mode 7 in the H/W variant.

When switching commutation states with active demagnetization disabled, dead time is inserted and the low-side MOSFET's body diode conducts while turning another high-side MOSFET on to continue sourcing current through the motor. This conduction period causes higher power losses due to the forward-bias voltage of the diode and slower dissipation of current. Figure 9-7 shows the body diode conducting when switching commutation states.

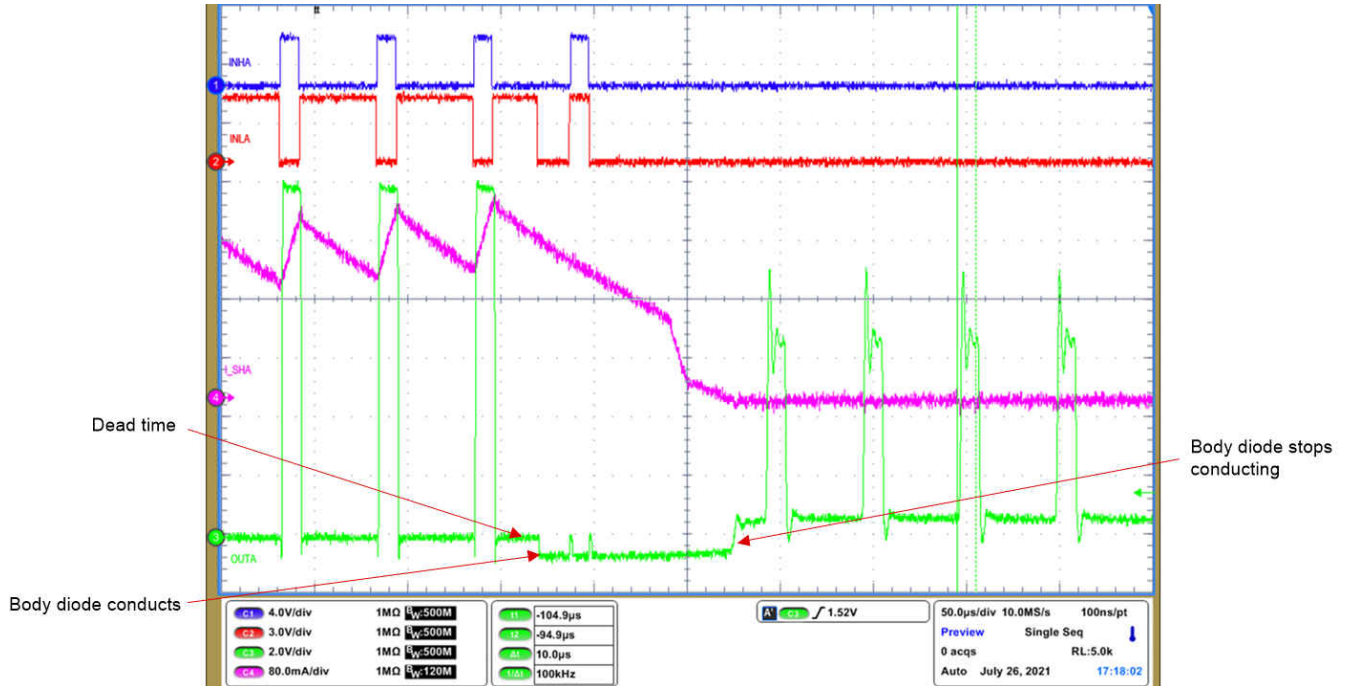

Figure 9-7. Active demagnetization disabled in MCT8316Z

When active demagnetization is enabled, the AD_HS and AD_LS comparators detect when the sense FET voltage is higher or lower than the programmed threshold. After the dead time period, if the threshold is exceeded for a fixed amount of time, the body diode is conducting and the logic core turns the low-side FET on to provide a conduction path with smaller power losses. Once the V_{DS} voltage is below the comparator threshold, the MOSFET turns off and current briefly conducts through the body diode until the current completely decays to zero. This is shown in Figure 9-8.

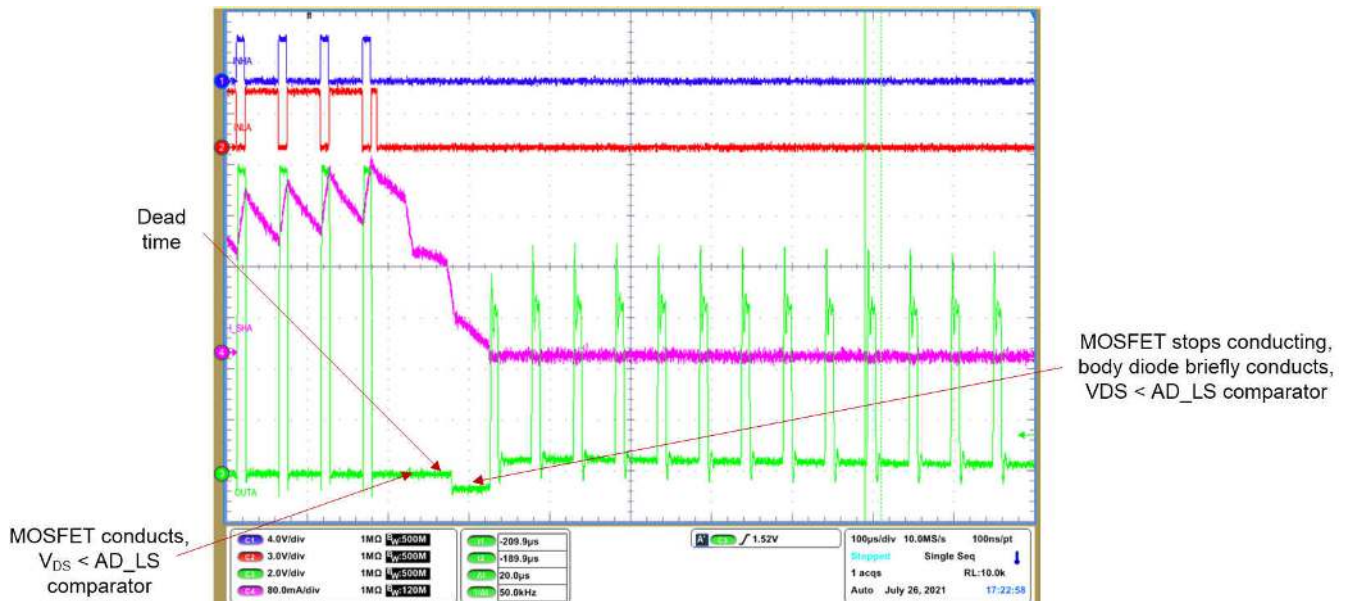

Figure 9-8. Active demagnetization enabled in MCT8316Z

9.3.1.1.3 Using Delay Compensation

Differences in delays of dead time and propagation delay can cause mismatch in the output timings of PWMs, which can lead to duty cycle distortion. In order to accommodate differences in propagation delay between various input conditions, the MCT8316ZR integrates a Delay Compensation feature.

Delay Compensation is used to match delay times for currents going into and out of phase by adding a variable delay time (t_{var}) to match a preset target delay time. This delay time is configurable in SPI devices, and it is recommended in the datasheets to choose a target delay time that is equal to the propagation delay time plus the driver dead time ($t_{pd} + t_{dead}$).

For an example of Delay Compensation implementation, please visit the [Delay and Dead Time in Integrated MOSFET Drivers](#) application note.

9.3.1.1.4 Using the Buck Regulator

In the MCT8316Z, the buck regulator components must be populated whether the buck is used or unused.

If unused, Resistor Mode should be configured by placing a small value resistor of 22-ohm for R_{BK} and a 6.3-V rated, 22- μ F capacitor for C_{BK} to minimize board space and reduce component cost. To disable the buck regulator, set the BUCK_DIS in the SPI variant. The buck cannot be disabled in the Hardware variant.

If the buck regulator is used, either the Inductor or Resistor Mode can be selected. Inductor Mode allows a 22- μ H or 47- μ H inductor be used for L_{BK} . C_{BK} is recommended to be 22- μ F. Ensure an appropriate inductor is chosen to allow for maximum peak saturation current at a 20% inductance drop since the buck can supply up to 600-mA external current.

Resistor Mode allows for power to be dissipated in an external resistor if the load requirement is less than 40-mA. Ensure the resistor is rated for the power dissipation required at worst case VM voltage dropout. See [Equation 5](#), [Equation 6](#), and [Equation 7](#) to calculate the resistor power rating required for a 24-V rated system, 3.3V buck output voltage, and 20-mA load current.

$$P_{R_{BK}} > (V_M - V_{BK}) \times I_{BK} \quad (5)$$

$$P_{R_{BK}} > (24V - 3.3V) \times 20mA \quad (6)$$

$$P_{R_{BK}} > 0.434W \quad (7)$$

9.3.1.1.5 Power Dissipation and Junction Temperature Losses

To calculate the junction temperature of the MCT8316Z from power losses, use [Equation 8](#). Note that the thermal resistance θ_{JA} depends on PCB configurations such as the ambient temperature, numbers of PCB layers, copper thickness on top and bottom layers, and the PCB area.

$$T_J[^\circ C] = P_{loss}[W] \times \theta_{JA}[\frac{^\circ C}{W}] + T_A[^\circ C] \quad (8)$$

9.3.1.2 Application Curves

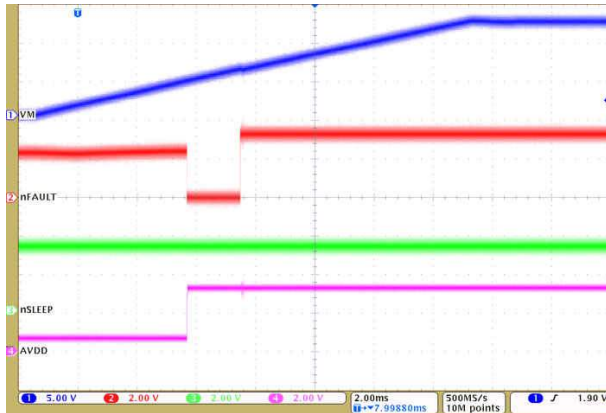

Figure 9-9. Device Powerup with VM

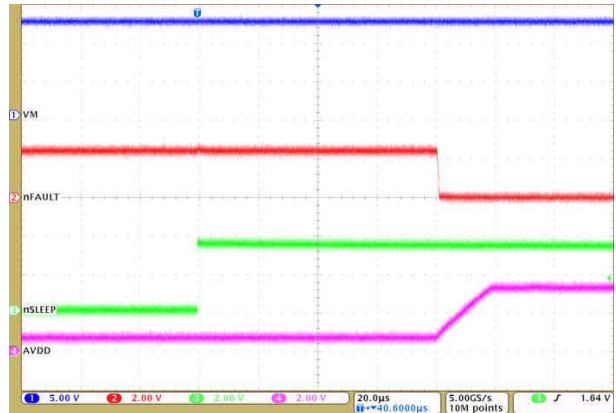

Figure 9-10. Device Powerup with nSLEEP

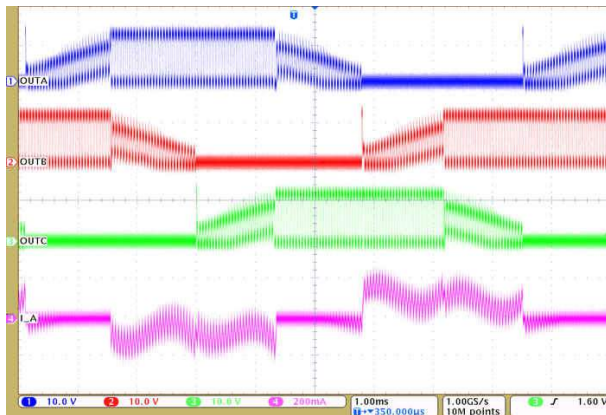

Figure 9-11. Driver PWM Operation

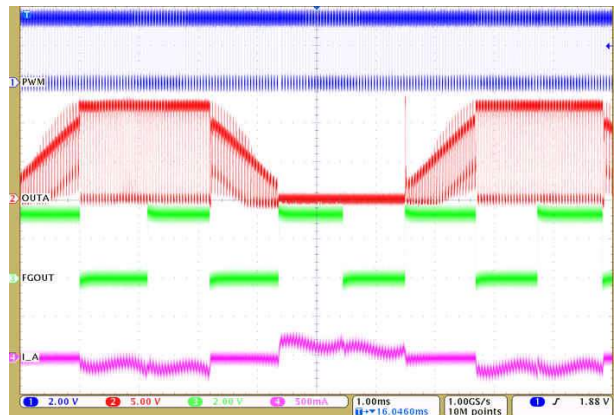

Figure 9-12. Driver PWM Operation with FGOUT

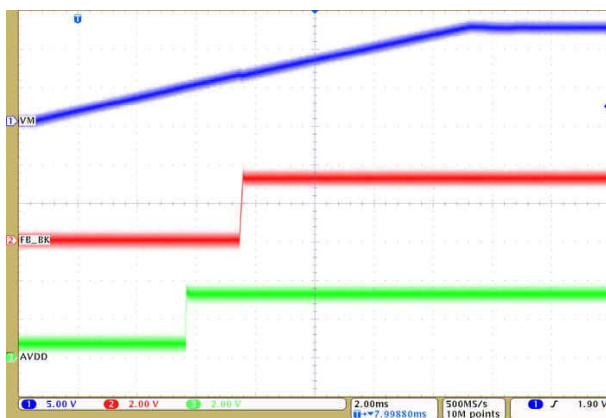

Figure 9-13. Power Management

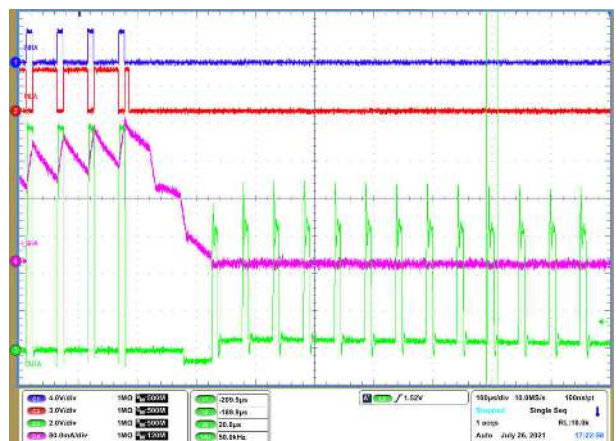

Figure 9-14. Driver PWM with Active Demagnetization (ASR and AAR)



Figure 9-15. Driver PWM Operation with Current Limit

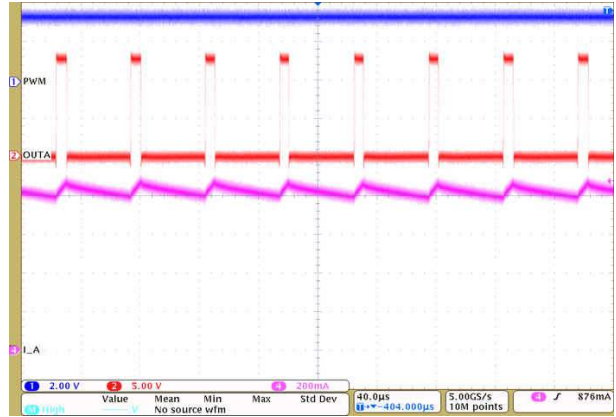

Figure 9-16. Driver 100% Operation with Current Chopping

10 Power Supply Recommendations

10.1 Bulk Capacitance

Having an appropriate local bulk capacitance is an important factor in motor drive system design. It is generally beneficial to have more bulk capacitance, while the disadvantages are increased cost and physical size.

The amount of local capacitance needed depends on a variety of factors, including:

- The highest current required by the motor system
- The capacitance and current capability of the power supply
- The amount of parasitic inductance between the power supply and motor system
- The acceptable voltage ripple
- The type of motor used (brushed dc, brushless DC, stepper)
- The motor braking method

The inductance between the power supply and the motor drive system limits the rate current can change from the power supply. If the local bulk capacitance is too small, the system responds to excessive current demands or dumps from the motor with a change in voltage. When adequate bulk capacitance is used, the motor voltage remains stable and high current can be quickly supplied.

The data sheet generally provides a recommended value, but system-level testing is required to determine the appropriate sized bulk capacitor.

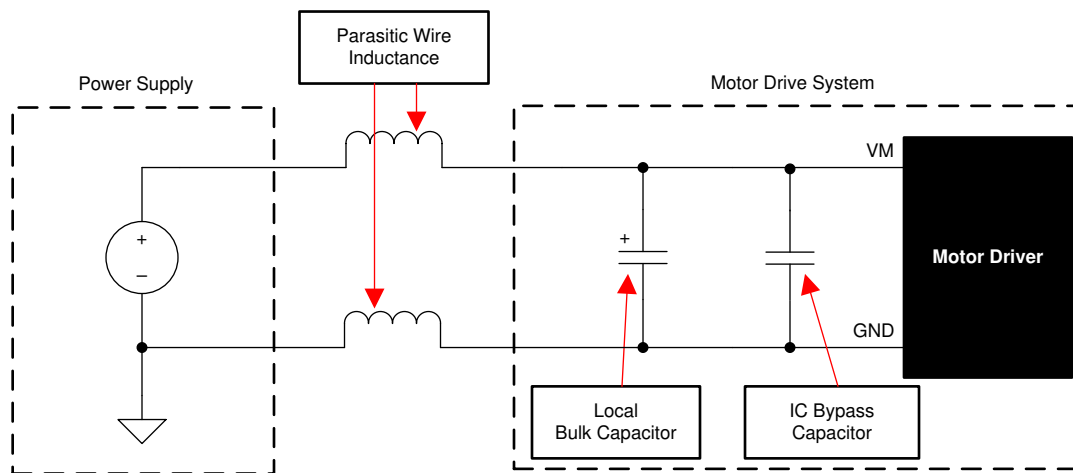

Figure 10-1. Example Setup of Motor Drive System With External Power Supply

The voltage rating for bulk capacitors should be higher than the operating voltage, to provide margin for cases when the motor transfers energy to the supply.

11 Layout

11.1 Layout Guidelines

The bulk capacitor should be placed to minimize the distance of the high-current path through the motor driver device. The connecting metal trace widths should be as wide as possible, and numerous vias should be used when connecting PCB layers. These practices minimize inductance and allow the bulk capacitor to deliver high current.

Small-value capacitors such as the charge pump, AVDD, and VREF capacitors should be ceramic and placed closely to device pins.

The high-current device outputs should use wide metal traces.

To reduce noise coupling and EMI interference from large transient currents into small-current signal paths, grounding should be partitioned between PGND and AGND. TI recommends connecting all non-power stage circuitry (including the thermal pad) to AGND to reduce parasitic effects and improve power dissipation from the device. Optionally, GND_BK can be split. Ensure grounds are connected through net-ties or wide resistors to reduce voltage offsets and maintain gate driver performance.

The device thermal pad should be soldered to the PCB top-layer ground plane. Multiple vias should be used to connect to a large bottom-layer ground plane. The use of large metal planes and multiple vias helps dissipate the $I_2 \times RDS(on)$ heat that is generated in the device.

To improve thermal performance, maximize the ground area that is connected to the thermal pad ground across all possible layers of the PCB. Using thick copper pours can lower the junction-to-air thermal resistance and improve thermal dissipation from the die surface.

Separate the SW_BUCK and FB_BUCK traces with ground separation to reduce buck switching from coupling as noise into the buck outer feedback loop. Widen the FB_BUCK trace as much as possible to allow for faster load switching.

[Recommended Layout Example for VQFN Package](#) shows a layout example for the MCT8316Z.

11.2 Layout Example

Recommended Layout Example for VQFN Package

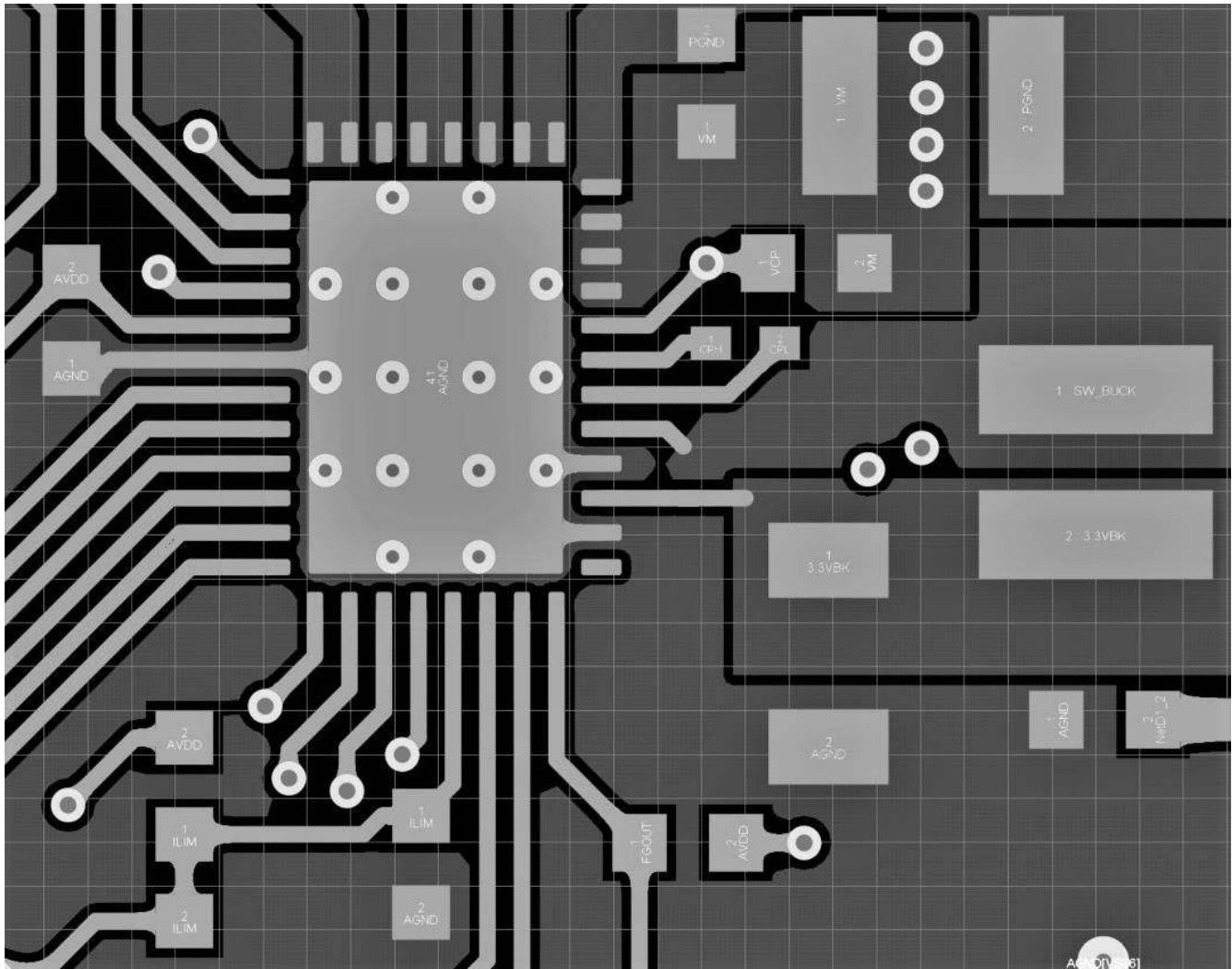

11.3 Thermal Considerations

The MCT8316Z has thermal shutdown (TSD) as previously described. A die temperature in excess of 150°C (minimally) disables the device until the temperature drops to a safe level.

Any tendency of the device to enter thermal shutdown is an indication of excessive power dissipation, insufficient heatsinking, or too high an ambient temperature.

11.3.1 Power Dissipation

The power dissipated in the output FET resistance, or $R_{DS(on)}$ dominates power dissipation in the MCT8316Z.

At start-up and fault conditions, this current is much higher than normal running current; remember to take these peak currents and their duration into consideration.

The total device dissipation is the power dissipated in each of the three half-H-bridges added together.

The maximum amount of power that the device can dissipate depends on ambient temperature and heatsinking.

Note that $R_{DS(on)}$ increases with temperature, so as the device heats, the power dissipation increases. Take this into consideration when sizing the heatsink.

A summary of equations for calculating each loss is shown below for trapezoidal control.

Table 11-1. MCT8316Z Power Losses for Trapezoidal Control

Loss type	Trapezoidal
Standby power	$P_{standby} = V_M \times I_{VM_TA}$
LDO (from VM)	$P_{LDO} = (V_M - V_{AVDD}) \times I_{AVDD}$
FET conduction	$P_{CON} = 2 \times I_{RMS(trap)} \times R_{ds,on(TA)}$
FET switching	$P_{SW} = I_{PK(trap)} \times V_{PK(trap)} \times t_{rise/fall} \times f_{PWM}$
Diode	$P_{diode} = I_{RMS(trap)} \times V_{diode} \times t_{diode} \times f_{PWM}$
Buck	$P_{BK} = 0.97 \times V_{BK} \times I_{BK}$

12 Device and Documentation Support

12.1 Support Resources

[TI E2E™ support forums](#) are an engineer's go-to source for fast, verified answers and design help — straight from the experts. Search existing answers or ask your own question to get the quick design help you need.

Linked content is provided "AS IS" by the respective contributors. They do not constitute TI specifications and do not necessarily reflect TI's views; see TI's [Terms of Use](#).

12.2 Trademarks

TI E2E™ is a trademark of Texas Instruments.

All trademarks are the property of their respective owners.

12.3 Electrostatic Discharge Caution



This integrated circuit can be damaged by ESD. Texas Instruments recommends that all integrated circuits be handled with appropriate precautions. Failure to observe proper handling and installation procedures can cause damage.

ESD damage can range from subtle performance degradation to complete device failure. Precision integrated circuits may be more susceptible to damage because very small parametric changes could cause the device not to meet its published specifications.

12.4 Glossary

[TI Glossary](#) This glossary lists and explains terms, acronyms, and definitions.

RGF0040E

PACKAGE OUTLINE

VQFN - 1 mm max height

PLASTIC QUAD FLAT PACK- NO LEAD

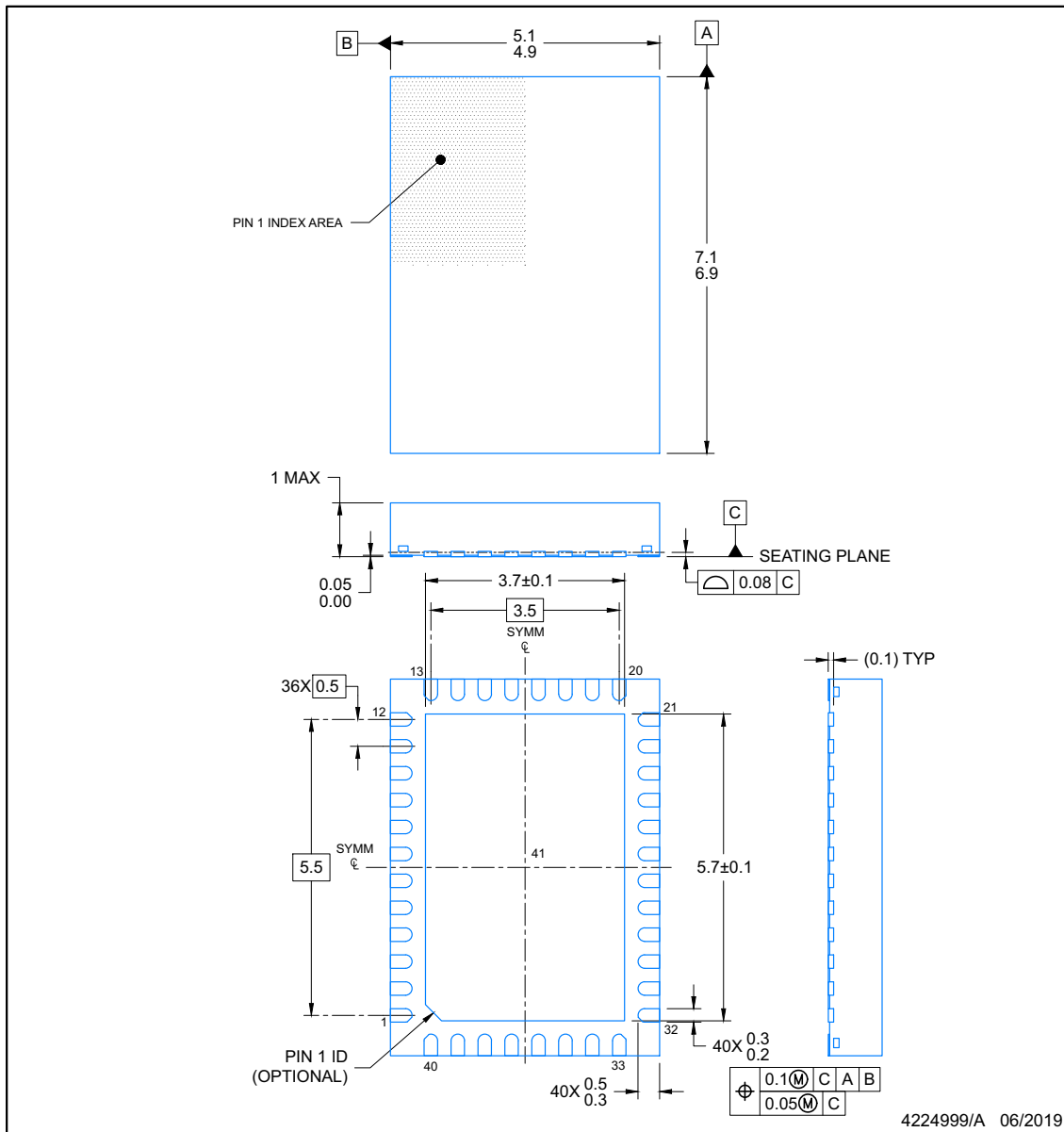

NOTES:

1. All linear dimensions are in millimeters. Any dimensions in parenthesis are for reference only. Dimensioning and tolerancing per ASME Y14.5M.
2. This drawing is subject to change without notice.
3. The package thermal pad must be soldered to the printed circuit board for optimal thermal and mechanical performance.

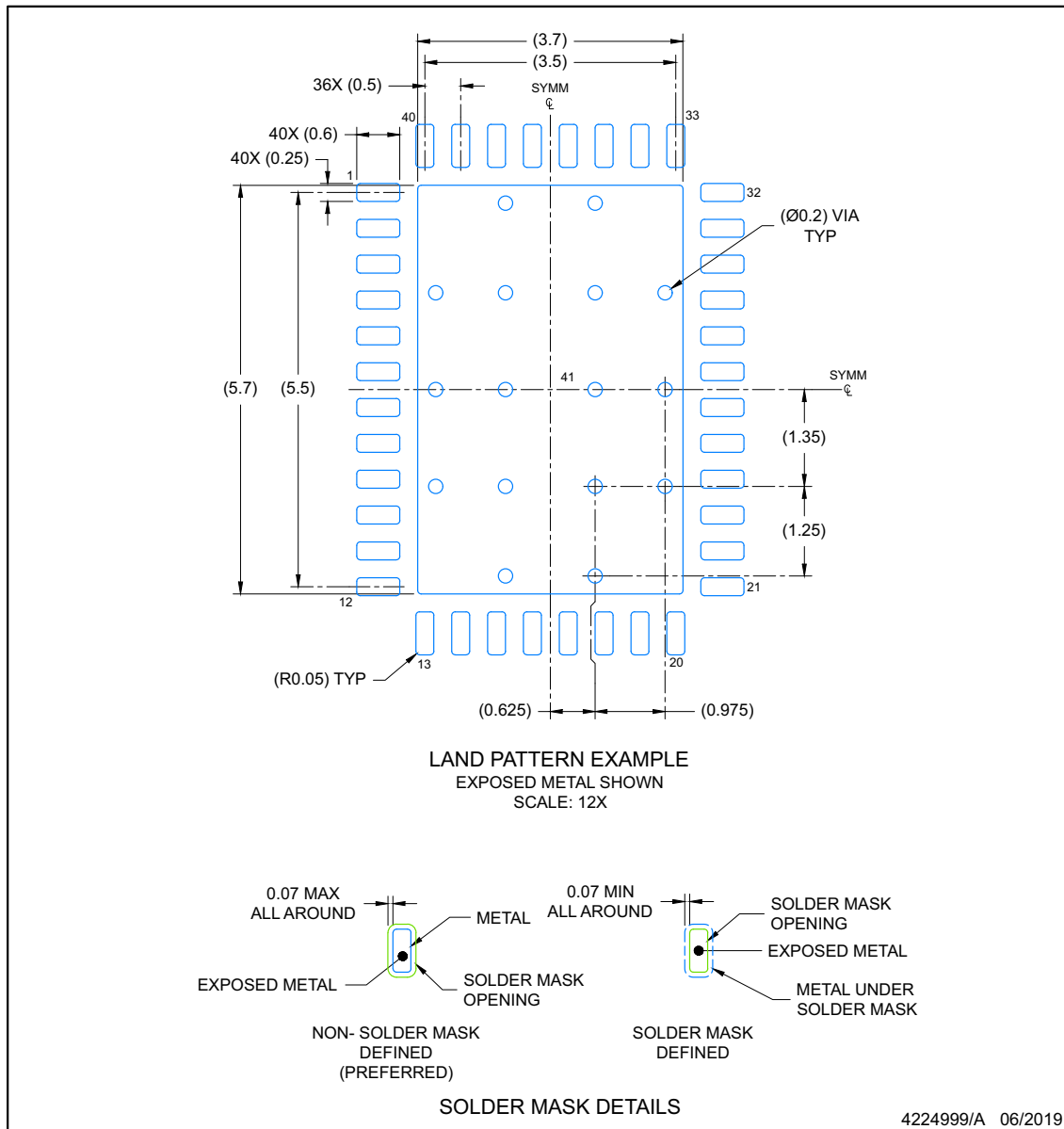

NOTES: (continued)

4. This package is designed to be soldered to a thermal pad on the board. For more information, see Texas Instruments literature number SLUA271 (www.ti.com/lit/sluea271).
5. Vias are optional depending on application, refer to device data sheet. If any vias are implemented, refer to their locations shown on this view. It is recommended that vias under paste be filled, plugged or tented.

EXAMPLE STENCIL DESIGN

RGF0040E

VQFN - 1 mm max height

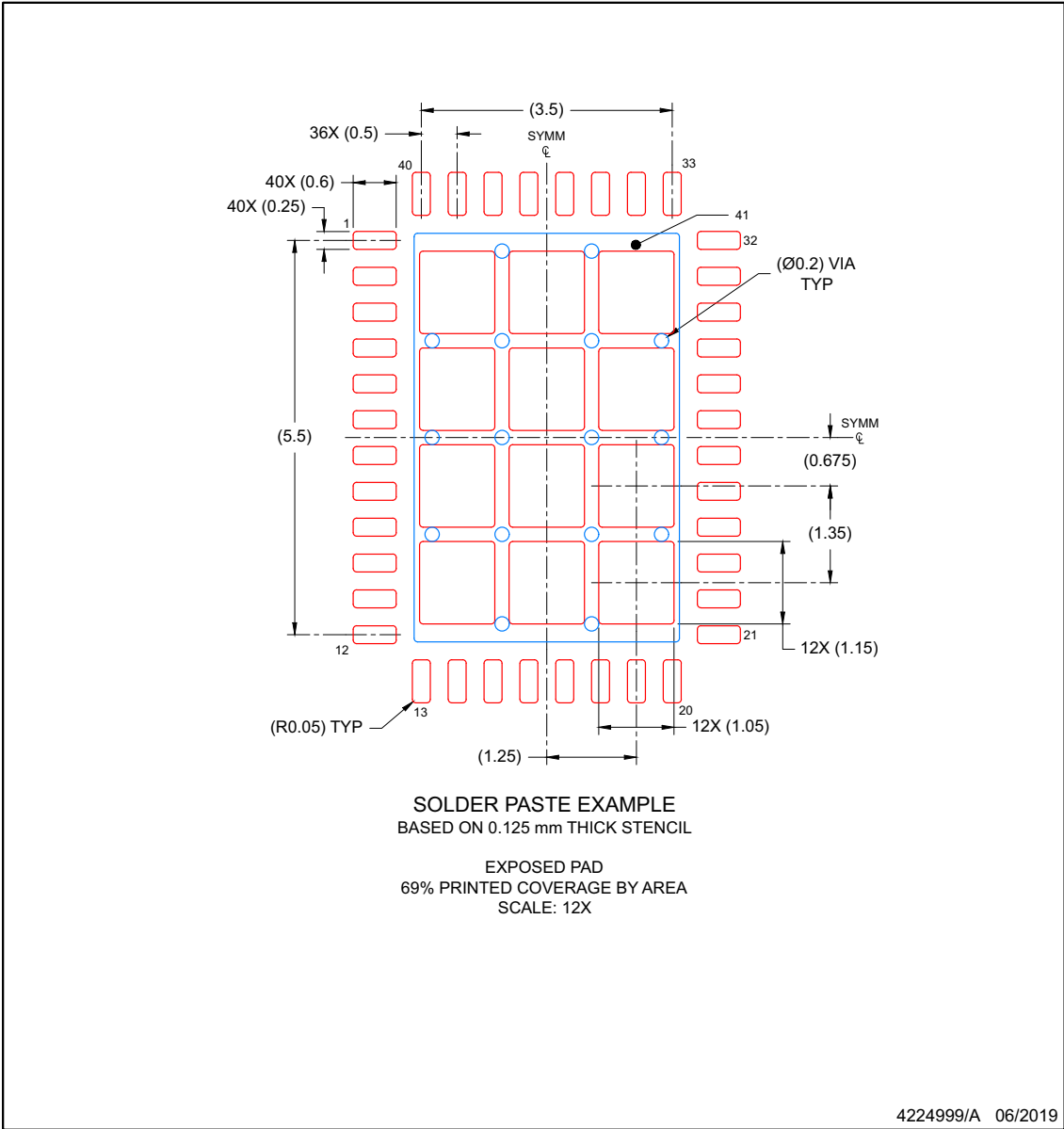

PLASTIC QUAD FLAT PACK- NO LEAD



NOTES: (continued)

6. Laser cutting apertures with trapezoidal walls and rounded corners may offer better paste release. IPC-7525 may have alternate design recommendations.

PACKAGING INFORMATION

Orderable Device	Status (1)	Package Type	Package Drawing	Pins	Package Qty	Eco Plan (2)	Lead finish/ Ball material (6)	MSL Peak Temp (3)	Op Temp (°C)	Device Marking (4/5)	Samples
MCT8316Z0RRGFR	ACTIVE	VQFN	RGF	40	3000	RoHS & Green	NIPDAU	Level-2-260C-1 YEAR	-40 to 125	MCT 8316ZR	
MCT8316Z0TRGFR	ACTIVE	VQFN	RGF	40	3000	RoHS & Green	NIPDAU	Level-2-260C-1 YEAR	-40 to 125	MCT 8316ZT	

(1) The marketing status values are defined as follows:

ACTIVE: Product device recommended for new designs.

LIFEBUY: TI has announced that the device will be discontinued, and a lifetime-buy period is in effect.

NRND: Not recommended for new designs. Device is in production to support existing customers, but TI does not recommend using this part in a new design.

PREVIEW: Device has been announced but is not in production. Samples may or may not be available.

OBSOLETE: TI has discontinued the production of the device.

(2) **RoHS:** TI defines "RoHS" to mean semiconductor products that are compliant with the current EU RoHS requirements for all 10 RoHS substances, including the requirement that RoHS substance do not exceed 0.1% by weight in homogeneous materials. Where designed to be soldered at high temperatures, "RoHS" products are suitable for use in specified lead-free processes. TI may reference these types of products as "Pb-Free".

RoHS Exempt: TI defines "RoHS Exempt" to mean products that contain lead but are compliant with EU RoHS pursuant to a specific EU RoHS exemption.

Green: TI defines "Green" to mean the content of Chlorine (Cl) and Bromine (Br) based flame retardants meet JS709B low halogen requirements of <=1000ppm threshold. Antimony trioxide based flame retardants must also meet the <=1000ppm threshold requirement.

(3) MSL, Peak Temp. - The Moisture Sensitivity Level rating according to the JEDEC industry standard classifications, and peak solder temperature.

(4) There may be additional marking, which relates to the logo, the lot trace code information, or the environmental category on the device.

(5) Multiple Device Markings will be inside parentheses. Only one Device Marking contained in parentheses and separated by a "~" will appear on a device. If a line is indented then it is a continuation of the previous line and the two combined represent the entire Device Marking for that device.

(6) Lead finish/Ball material - Orderable Devices may have multiple material finish options. Finish options are separated by a vertical ruled line. Lead finish/Ball material values may wrap to two lines if the finish value exceeds the maximum column width.

Important Information and Disclaimer:The information provided on this page represents TI's knowledge and belief as of the date that it is provided. TI bases its knowledge and belief on information provided by third parties, and makes no representation or warranty as to the accuracy of such information. Efforts are underway to better integrate information from third parties. TI has taken and continues to take reasonable steps to provide representative and accurate information but may not have conducted destructive testing or chemical analysis on incoming materials and chemicals. TI and TI suppliers consider certain information to be proprietary, and thus CAS numbers and other limited information may not be available for release.

In no event shall TI's liability arising out of such information exceed the total purchase price of the TI part(s) at issue in this document sold by TI to Customer on an annual basis.

OTHER QUALIFIED VERSIONS OF MCT8316Z :

- Automotive : [MCT8316Z-Q1](#)

NOTE: Qualified Version Definitions:

- Automotive - Q100 devices qualified for high-reliability automotive applications targeting zero defects

TAPE AND REEL INFORMATION

QUADRANT ASSIGNMENTS FOR PIN 1 ORIENTATION IN TAPE

*All dimensions are nominal

Device	Package Type	Package Drawing	Pins	SPQ	Reel Diameter (mm)	Reel Width W1 (mm)	A0 (mm)	B0 (mm)	K0 (mm)	P1 (mm)	W (mm)	Pin1 Quadrant
MCT8316Z0RRGFR	VQFN	RGF	40	3000	330.0	16.4	5.25	7.25	1.45	8.0	16.0	Q1
MCT8316Z0TRGFR	VQFN	RGF	40	3000	330.0	16.4	5.25	7.25	1.45	8.0	16.0	Q1

TAPE AND REEL BOX DIMENSIONS

*All dimensions are nominal

Device	Package Type	Package Drawing	Pins	SPQ	Length (mm)	Width (mm)	Height (mm)
MCT8316Z0RRGFR	VQFN	RGF	40	3000	367.0	367.0	35.0
MCT8316Z0TRGFR	VQFN	RGF	40	3000	367.0	367.0	35.0

GENERIC PACKAGE VIEW

RGF 40

VQFN - 1 mm max height

5 x 7, 0.5 mm pitch

PLASTIC QUAD FLAT PACK- NO LEAD

This image is a representation of the package family, actual package may vary.
Refer to the product data sheet for package details.



4225115/A

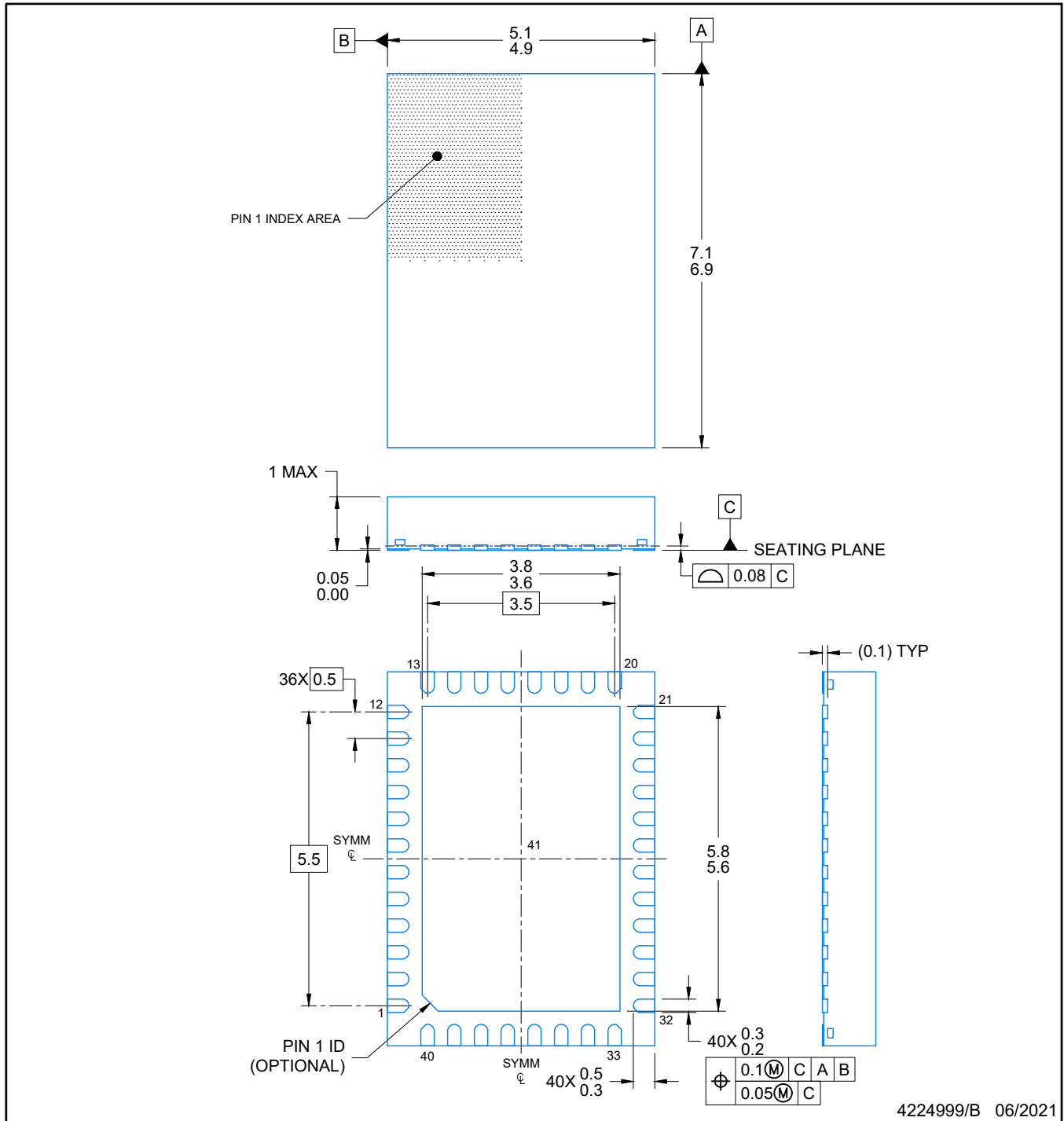

4224999/B 06/2021

NOTES:

1. All linear dimensions are in millimeters. Any dimensions in parenthesis are for reference only. Dimensioning and tolerancing per ASME Y14.5M.
2. This drawing is subject to change without notice.
3. The package thermal pad must be soldered to the printed circuit board for optimal thermal and mechanical performance.

EXAMPLE BOARD LAYOUT

RGF0040E

VQFN - 1 mm max height

PLASTIC QUAD FLAT PACK- NO LEAD

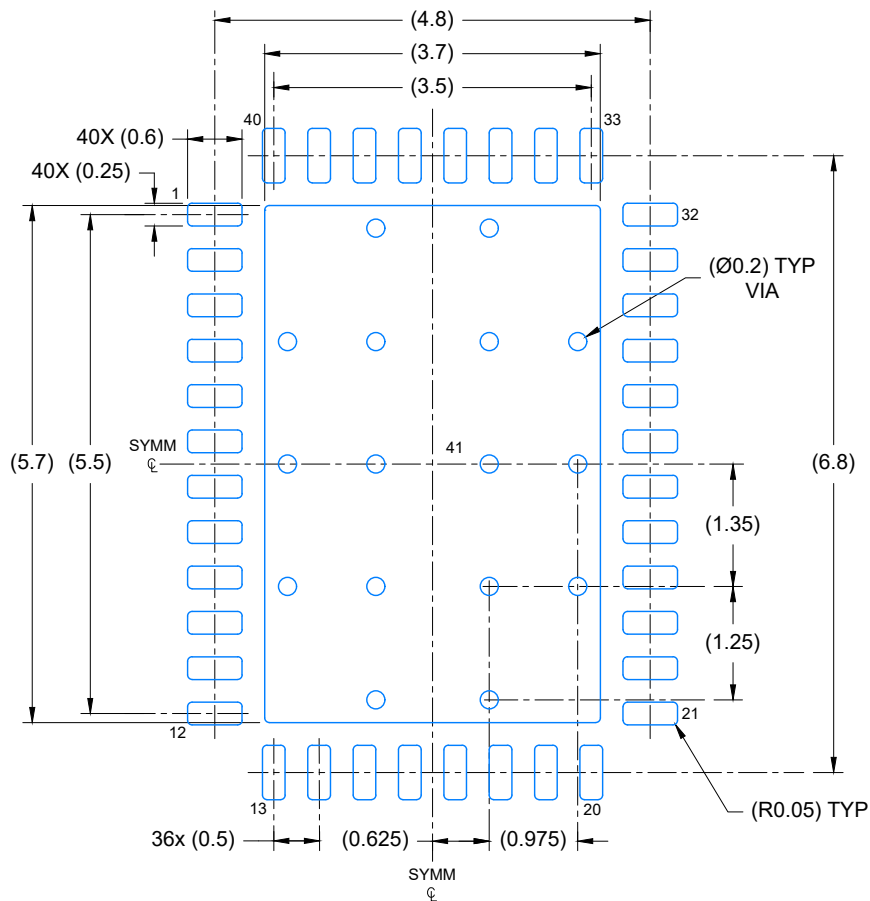

LAND PATTERN EXAMPLE
EXPOSED METAL SHOWN
SCALE: 12X

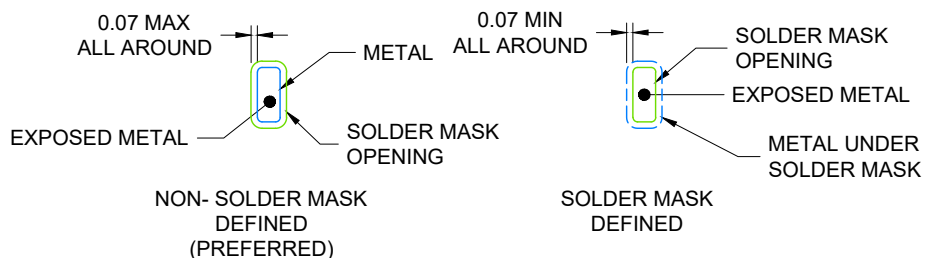

SOLDER MASK DETAILS

4224999/B 06/2021

NOTES: (continued)

4. This package is designed to be soldered to a thermal pad on the board. For more information, see Texas Instruments literature number SLUA271 (www.ti.com/lit/slua271).
5. Vias are optional depending on application, refer to device data sheet. If any vias are implemented, refer to their locations shown on this view. It is recommended that vias under paste be filled, plugged or tented.

EXAMPLE STENCIL DESIGN

RGF0040E

VQFN - 1 mm max height

PLASTIC QUAD FLAT PACK- NO LEAD

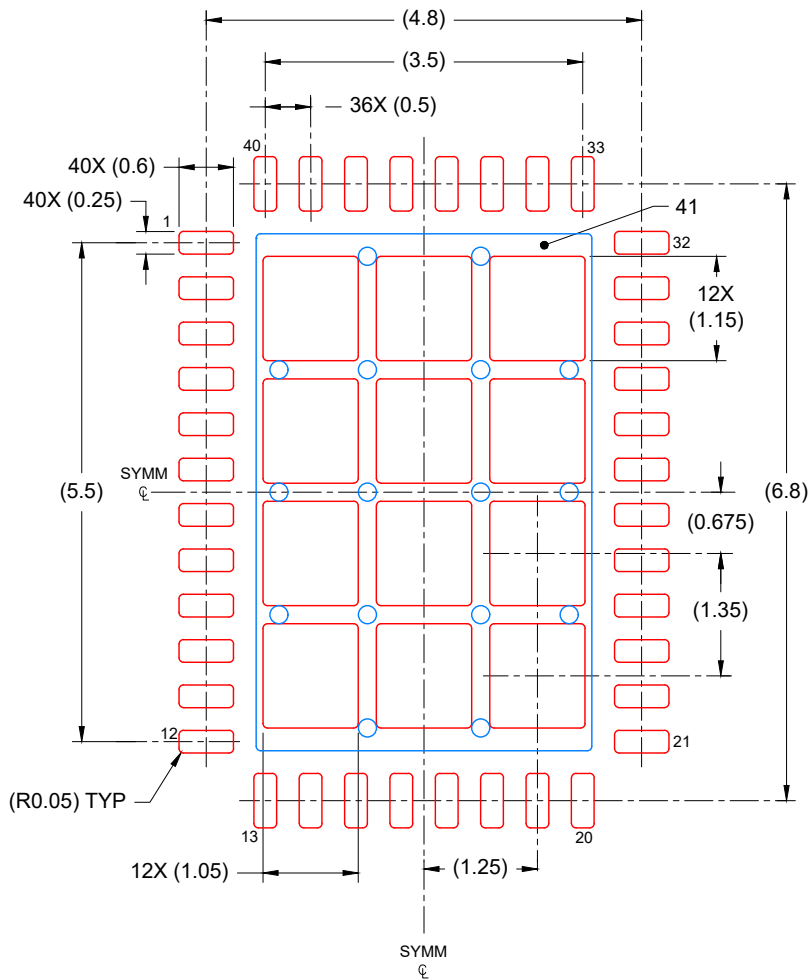

SOLDER PASTE EXAMPLE
BASED ON 0.125 mm THICK STENCIL

EXPOSED PAD
69% PRINTED COVERAGE BY AREA
SCALE: 12X

4224999/B 06/2021

NOTES: (continued)

6. Laser cutting apertures with trapezoidal walls and rounded corners may offer better paste release. IPC-7525 may have alternate design recommendations.

IMPORTANT NOTICE AND DISCLAIMER

TI PROVIDES TECHNICAL AND RELIABILITY DATA (INCLUDING DATA SHEETS), DESIGN RESOURCES (INCLUDING REFERENCE DESIGNS), APPLICATION OR OTHER DESIGN ADVICE, WEB TOOLS, SAFETY INFORMATION, AND OTHER RESOURCES "AS IS" AND WITH ALL FAULTS, AND DISCLAIMS ALL WARRANTIES, EXPRESS AND IMPLIED, INCLUDING WITHOUT LIMITATION ANY IMPLIED WARRANTIES OF MERCHANTABILITY, FITNESS FOR A PARTICULAR PURPOSE OR NON-INFRINGEMENT OF THIRD PARTY INTELLECTUAL PROPERTY RIGHTS.

These resources are intended for skilled developers designing with TI products. You are solely responsible for (1) selecting the appropriate TI products for your application, (2) designing, validating and testing your application, and (3) ensuring your application meets applicable standards, and any other safety, security, regulatory or other requirements.

These resources are subject to change without notice. TI grants you permission to use these resources only for development of an application that uses the TI products described in the resource. Other reproduction and display of these resources is prohibited. No license is granted to any other TI intellectual property right or to any third party intellectual property right. TI disclaims responsibility for, and you will fully indemnify TI and its representatives against, any claims, damages, costs, losses, and liabilities arising out of your use of these resources.

TI's products are provided subject to [TI's Terms of Sale](#) or other applicable terms available either on ti.com or provided in conjunction with such TI products. TI's provision of these resources does not expand or otherwise alter TI's applicable warranties or warranty disclaimers for TI products.

TI objects to and rejects any additional or different terms you may have proposed.

Mailing Address: Texas Instruments, Post Office Box 655303, Dallas, Texas 75265
Copyright © 2022, Texas Instruments Incorporated