

REVISIONS			
REV	DESCRIPTION, ECN, EAR NO.	DATE	APP'D
H	PRODUCT DWG (EAR 13897)	JUN27/11	K.L.

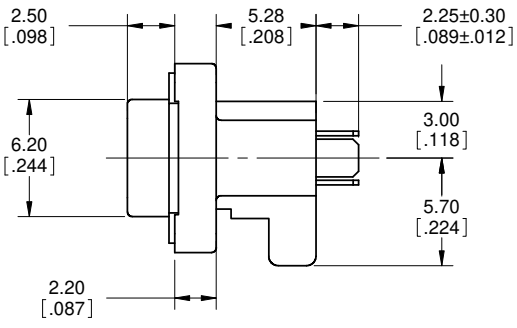
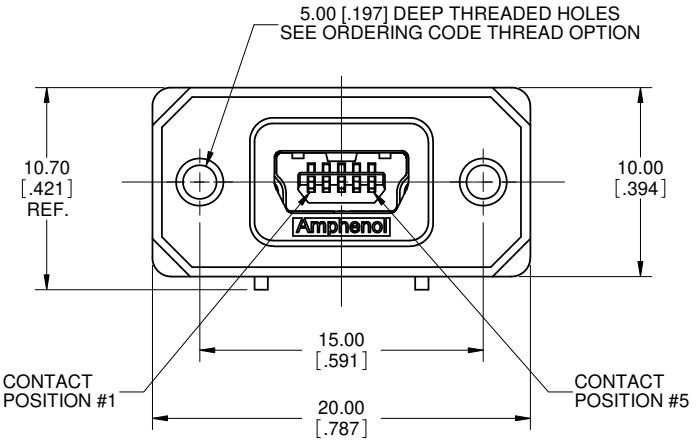

ORDERING CODE: MUSB-B551-XX

SERIES, RUGGED USB

USB 'MINI-B' RECEPTACLE, SINGLE PORT, VERTICAL PCB TAILS

THREAD OPTION
0 = #2-56 UNC THREAD
N = M2.5 X 0.45 THREAD

DUST COVER OPTION
0 = NO DUST COVER SUPPLIED
1 = WITH GREY DUST COVER SUPPLIED
4 = NO DUST COVER SUPPLIED
5 = WITH BLACK DUST COVER SUPPLIED

NOTE: THERE IS NO DIFFERENCE BETWEEN DUST COVER OPTIONS '0' AND '4'

SPECIAL CONNECTORS:
MANY UNIQUE FEATURES ARE READILY AVAILABLE TO SUIT CUSTOMER REQUIREMENTS. CONSULT WITH AMPHENOL CANADA FOR DETAILS.

NOTES:

- MATERIAL:**
ALL MATERIALS ARE RoHS COMPLIANT PER EU DIRECTIVE 2002/95/EC AND AMENDMENTS
 - OUTER SHELL: DIE CAST ZINC ALLOY, NICKEL PLATED
 - CONTACTS: PHOSPHOR BRONZE, PLATED WITH 0.76 MICRONS [30u"] GOLD OVER 1.27 MICRONS [50u"] MINIMUM NICKEL ON THE MATING AREA WITH GOLD FLASH OVER NICKEL ON THE TAILS.
 - USB HOUSING: ENGINEERING THERMOPLASTIC, FLAMMABILITY RATING UL94V-0, BLACK.
 - USB SHELL: COPPER ALLOY, NICKEL PLATED
 - GASKET: PORON WITH ADHESIVE BACKING.
 - DUST COVER: SILICONE RUBBER WITH NICKEL PLATED COPPER ALLOY BUSHING.
- ENVIRONMENTAL PERFORMANCE PER IEC 60529 CODE IP67 FOR SEAL BETWEEN MATING AREA AND PCB SIDE OF CONNECTOR. GASKET PROVIDES SEAL TO INSIDE FACE OF ENCLOSURE PANEL. AVAILABLE DUST COVER PROVIDES ADDED PROTECTION. SEE SHEET 2 FOR APPLICATION VIEW.
- CURRENT RATING: 1 AMPERE.
- CONTACT RESISTANCE: 50 MILLIOHMS MAXIMUM.
- OPERATING TEMPERATURE: -40°C TO +105°C.
- DUST COVERS MAY BE ORDERED SEPARATELY. SPECIFY
 - MUSB-2E151-005BP FOR GREY DUST COVER
 - MUSB-2E151-015BP FOR BLACK DUST COVER
- RECOMMENDED TORQUE FOR PANEL MOUNT SCREWS: 0.23 TO 0.34 N.m (2.00 TO 3.00 IN-LBS) FOR SCREWS WITH 2.50mm (.098") THREAD ENGAGEMENT.
- RECOMMENDED ENCLOSURE PANEL: 1.20 TO 2.50mm (.047 TO .098") THICK.

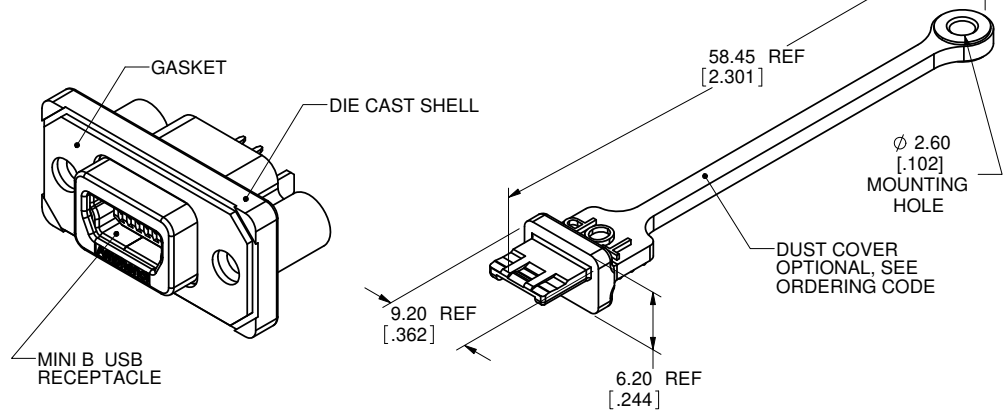
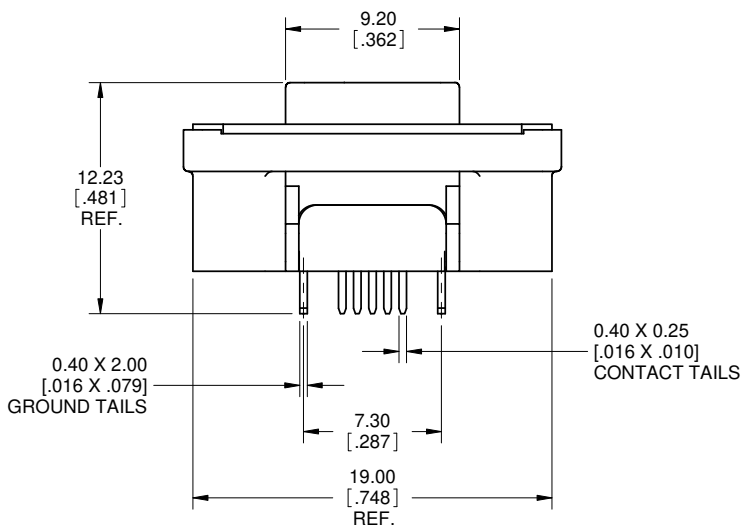

UNLESS SPECIFIED OTHERWISE	DRAWN	S.SEMENOV	FEB23/07
PRIMARY UNITS MILLIMETERS	CHECKED		
SECONDARY UNITS INCHES	M.E. APP'D		
REFERENCE IN PARENTHESES	Q.A. APP'D		
GENERAL TOLERANCES	DWG APPR.	A.GREEN	FEB23/07
1 DECIMAL PLACE	ENG. REL. NO.		
2 DECIMAL PLACES ±0.15	REF.	EAR 13430	
3 DECIMAL PLACES	THIRD ANGLE PROJECTION		
ANGULAR DEGREES	DO NOT SCALE DRAWING		

Amphenol Canada Corp. www.amphenolcanada.com			
MUSB SERIES RUGGED MINI-B USB RECEPTACLE, VERTICAL MOUNT, PCB TAIL, METAL SHELL, RoHS COMPLIANT			
DWG. NO.	P-MUSB-B551-XX		REV H
CODE ID NO. 03554	DWG SIZE: C	SCALE: 5:1	SHEET 1 OF 2

THIS DOCUMENT CONTAINS PROPRIETARY INFORMATION AND SUCH INFORMATION MAY NOT BE DISCLOSED TO OTHERS FOR ANY PURPOSE OR USED FOR MANUFACTURING PURPOSES WITHOUT WRITTEN PERMISSION FROM AMPHENOL CANADA CORP.

REVISIONS			
REV	DESCRIPTION, ECN, EAR NO.	DATE	APP'D
H	PRODUCT DWG (EAR 13897)	JUN27/11	K.L.

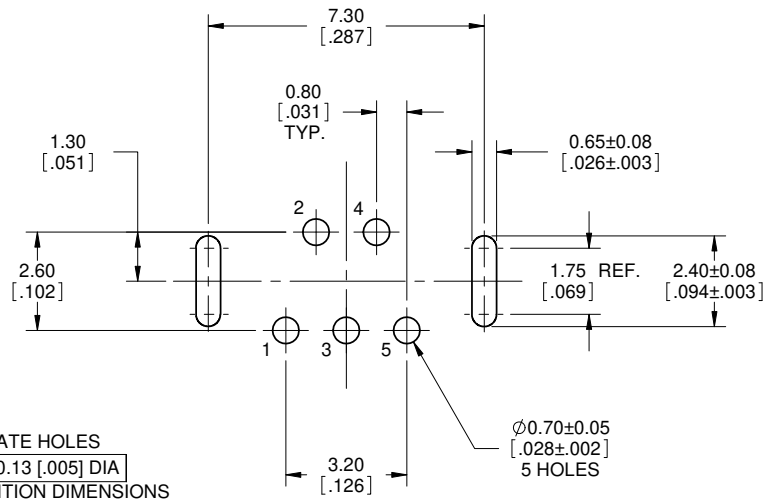

LOCATE HOLES
 $\phi 0.13$ [.005] DIA
 POSITION DIMENSIONS
 ARE BASIC

RECOMMENDED P.C.B. LAYOUT
 COMPONENT SIDE OF BOARD

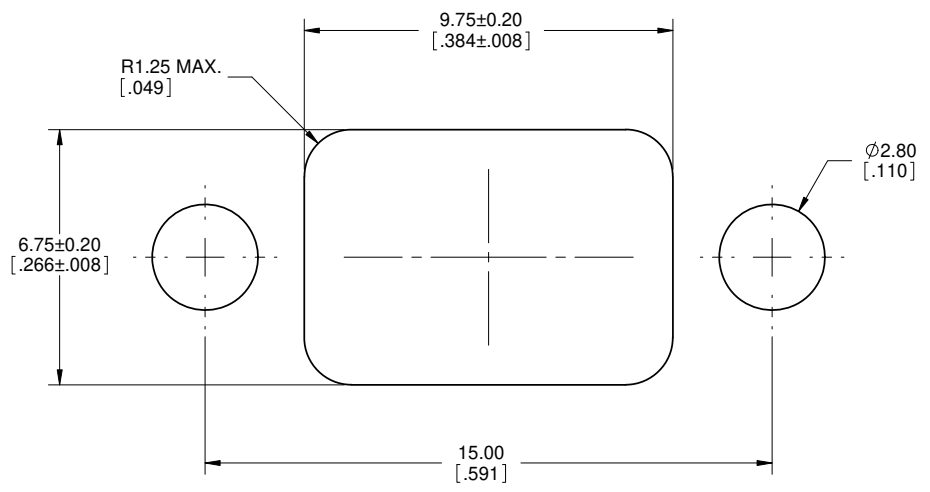

RECOMMENDED PANEL CUTOUT

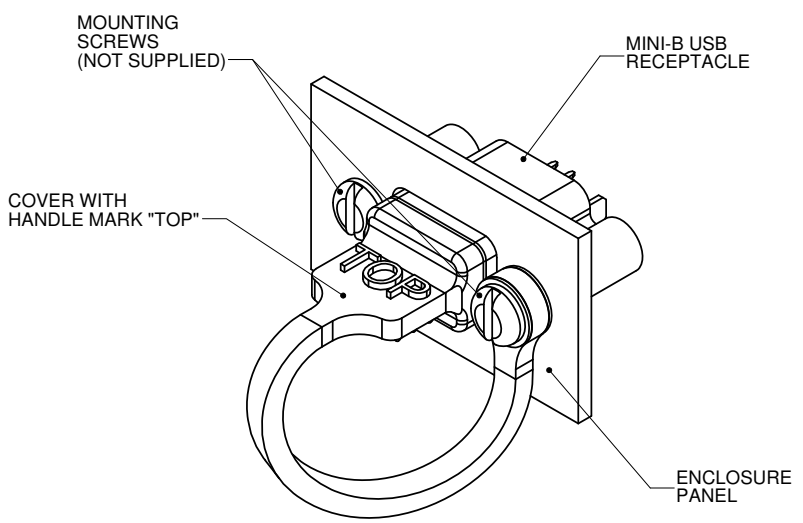

DUST COVER APPLICATION



THIS DOCUMENT CONTAINS PROPRIETARY INFORMATION AND SUCH INFORMATION MAY NOT BE DISCLOSED TO OTHERS FOR ANY PURPOSE OR USED FOR MANUFACTURING PURPOSES WITHOUT WRITTEN PERMISSION FROM AMPHENOL CANADA CORP.

UNLESS SPECIFIED OTHERWISE	DRAWN	S.SEMENOV	FEB23/07
PRIMARY UNITS MILLIMETERS	CHECKED		
SECONDARY UNITS INCHES	M.E. APP'D		
REFERENCE IN PARENTHESES	Q.A. APP'D		
GENERAL TOLERANCES	DWG APPR.	A.GREEN	FEB23/07
1 DECIMAL PLACE	ENG. REL. NO.		
2 DECIMAL PLACES ±0.15	REF.	EAR 13430	
3 DECIMAL PLACES	THIRD ANGLE PROJECTION		
ANGULAR DEGREES	DO NOT SCALE DRAWING		

Amphenol Canada Corp. www.amphenolcanada.com	
MUSB SERIES RUGGED MINI-B USB RECEPTACLE, VERTICAL MOUNT, PCB TAIL, METAL SHELL, RoHS COMPLIANT	
DWG. NO.	REV
P-MUSB-B551-XX	H
CODE ID NO. 03554	DWG SIZE: C
SCALE: 5:1	SHEET 2 OF 2