

PART NUMBER	REV	FIRST USED	POWER UNIT	FEED TYPE	DESCRIPTION
1855136-1	A	122500-1	LEADMAKER	AIR FEED	CUTS CARRIER
1855136-2	A	565435-5	BENCH MODEL K	AIR FEED	CUTS CARRIER
1855136-3	A	354500-1	BENCH MODEL G	AIR FEED	CUTS CARRIER
1855136-6	A	122500-1	LEADMAKER	AIR FEED	CONTINUOUS CARRIER
7-1855136-7	A	-	-	-	SPARE PARTS



TERMINAL NAME: TAXI TERM F M/P 280				
AMP	PACKARD	PACKARD TERMINAL - AMP CRIMP SPECS		
286710	12106636			
286712	12110646			
		CRIMP HEIGHT	WIRE SIZE	REF SETTING
-	-	.083±.002 [2.11±0.05mm]	12AWG	C2
-	-	.071±.002 [1.80±0.05mm]	14AWG	E3
-	-	-	-	-
-	-	-	-	-
-	-	CRIMP	SIZE	TYPE
-	-	WIRE	.120 [3.05mm]	F
-	-	INSUL	.180 [4.57mm]	F
-	-			∅.098-.144
WIRE STRIP LENGTH	TERM APPL SPEC	FEED	APPLICATOR INSTRUCTIONS	SET UP GAGE
.219-.250	NONE	.590	408-8040	458637-1

LOC	DIST	REVISIONS					
A	66	P	LTR	DESCRIPTION	DATE	DRN	APPR
		A		RELEASED	17NOV2006	RK	GB

- △ RECOMMENDED SPARE PARTS
- △ GREASE LIGHTLY
- △ GUARD MUST BE IN PLACE WHEN OPERATING APPLICATOR IN A BENCH MACHINE

*** WARNING**
 ON INSTALLATION, SET WIRE DISC TO LARGEST WIRE SIZE SETTING. USE OF SETTINGS BELOW MIN. REQUIRED CRIMP HEIGHT SETTING WILL CAUSE DAMAGE TO CRIMP TOOLING.

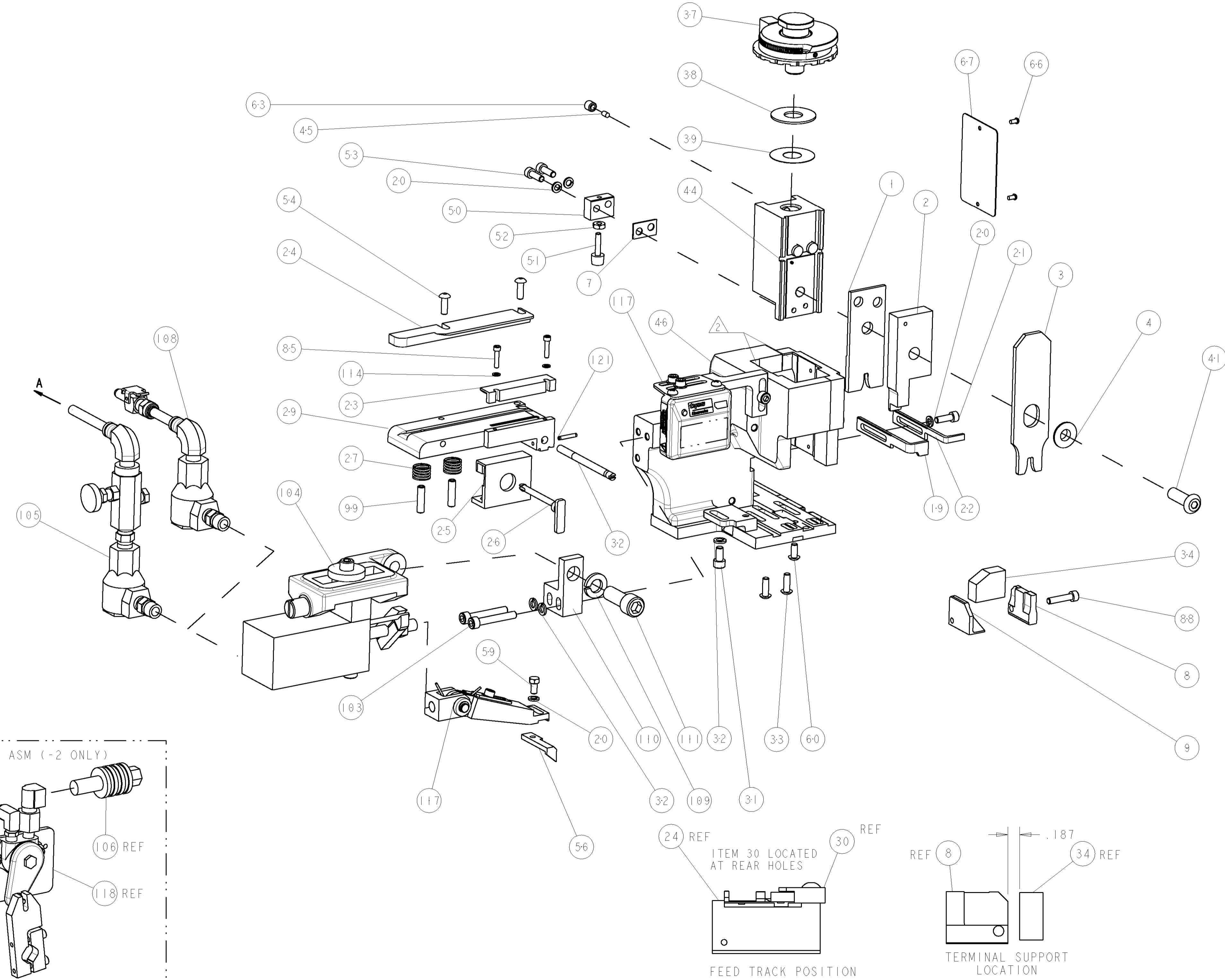

-	1	1	1	1	-	3-21028-7	PIN, SLOTTED SPRING .094 X .562	121
-	-	-	REF	-	-	692655-6	AIR FEED VALVE ASSEMBLY	118
-	1	1	1	1	-	461062-1	FEED FINGER ASSEMBLY	117
-	-	-	REF	-	..	455749-1	GUARD WINDOW	116
-	-	REF	-	-	..	679532-1	INSERT, GUARD	115
-	2	2	2	2	-	21024-2	WASHER, SPRG LOCK, REG NO 4	114
-	1	1	1	1	-	3-21001-5	SCR, SKT HD CAP 3/8-16 X 1.000	111
-	1	1	1	1	-	459610-1	MOUNT, FEED BRACKET	110
-	1	1	1	1	-	21024-8	WASHER, SPRG LOCK, REG 3/8	109
-	1	1	1	1	-	692655-7	AIR FEED VALVE ASSEMBLY	108
-	-	-	REF	-	-	24024-2	VALVE, SHUT OFF	106
-	-	-	1	-	-	692655-5	AIR FEED VALVE ASSEMBLY	105
-	1	1	1	1	-	461065-1	ASSEMBLY, AIR FEED	104
-	2	2	2	2	-	4-21000-0	SCR, SKT HD CAP 10-32 X 1.250	103
-	2	2	2	2	-	5-21006-6	SCR, SET, CUP POINT 10-32 X .750	99
-	1	1	1	1	-	2-21000-9	SCR, SKT HD CAP 8-32 X .750	88
-	2	2	2	2	-	1-21000-5	SCR, SKT HD CAP 4-40 X .500	85
-	1	1	1	1	-	4088040	SF APPL INST 408-8040	72
-	1	1	1	1	-	217238-1	GENERAL INSTRUCTION PKG	71
-	1	1	1	1	-	461264-5	PLATE, IDENTIFICATION	67
-	2	2	2	2	-	21017-2	SCREW, DRIVE	66
-	1	1	1	1	-	21009-2	SCR, SET, SELF LOCKING 1/4-20 X .250	63
-	1	1	1	1	-	22733-8	SCR, BHSC, SELF-LOCKING, 8-32 X .375	60
-	1	1	1	1	-	2-22603-0	SCR, HEX HD CAP 8-32 X .312	59
-	1	1	1	1	-	3-694433-2	FEED PAWL	56
-	2	2	2	2	-	2-21002-2	SCR, BTN SKT HD CAP 8-32 X .500	54
-	2	2	2	2	-	2-21000-7	SCR, SKT HD CAP 8-32 X .500	53
-	1	1	1	1	-	21018-5	NUT, HEX, REG 6-32	52
-	1	1	1	1	-	811242-2	BUMPER, HOLD DOWN	51
-	1	1	1	1	-	690753-1	SPACER, TONKER	50
-	1	1	1	1	-	1633399-1	APPL., BASIC AIR FEED SUB ASSY	46
-	1	1	1	1	-	690191-1	PLUG, NYLON	45
-	1	1	1	1	-	2-819307-1	RAM, SIDE FEED	44
-	1	1	1	1	-	690686-2	CRIMPER, BOLT SPECIAL	41
-	1	1	1	1	-	690125-1	SHIM SUB-ASSY	39
-	1	1	1	1	-	1-469367-1	SHIM	38
-	1	1	1	1	-	879103-2	FINE ADJUST HEAD ASSEMBLY	37
-	1	1	1	1	-	690786-1	TERMINAL SUPPORT	34
-	2	2	2	2	-	2-21002-2	SCR, BTN SKT HD CAP 8-32 X .500	33
-	1	1	1	1	-	690432-3	ADJUSTMENT SCREW	32
-	3	3	3	3	-	21024-5	WASHER, SPRG LOCK, REG NO 10	32
-	1	1	1	1	-	3-21000-4	SCR, SKT HD CAP 10-32 X .375	31
-	1	1	1	1	-	3-455671-9	PLATE, STRIP GUIDE	29
-	2	2	2	2	-	1-22284-0	SPRING, COMPRESSION	27
-	1	1	1	1	-	690546-1	LEVER, DRAG RELEASE	26
-	1	1	1	1	-	690754-7	DRAG, SPECIAL	25
-	1	1	1	1	-	1-690440-9	PLATE, STRIP GUIDE	24
-	1	1	1	1	-	1-690712-1	FRONT STRIP GUIDE	23
-	1	1	1	1	-	690472-2	STRIPPER	22
-	1	1	1	1	-	2-21000-7	SCR, SKT HD CAP 8-32 X .500	21
-	4	4	4	4	-	21024-4	WASHER, SPRG LOCK, REG NO 8	20
-	-	1	1	-	-	691353-1	STRIPPER	19
-	1	1	1	1	-	853714-5	PLATE, REAR SHEAR	9
-	1	1	1	1	-	1214596-3	ANVIL, SPECIAL COMBINATION	8
-	1	1	1	1	-	1-240641-9	SPACER	7
-	1	1	1	1	-	238009-1	BLOCK, FL CRIMPER SPACER	4
-	1	1	1	1	-	4-456134-6	CRIMPER, INSULATION F PREMIUM	3
-	1	1	1	1	-	853720-5	BLADE, SLUG	2
-	1	1	1	1	-	6-458141-8	CRIMPER, WIRE PREMIUM	1

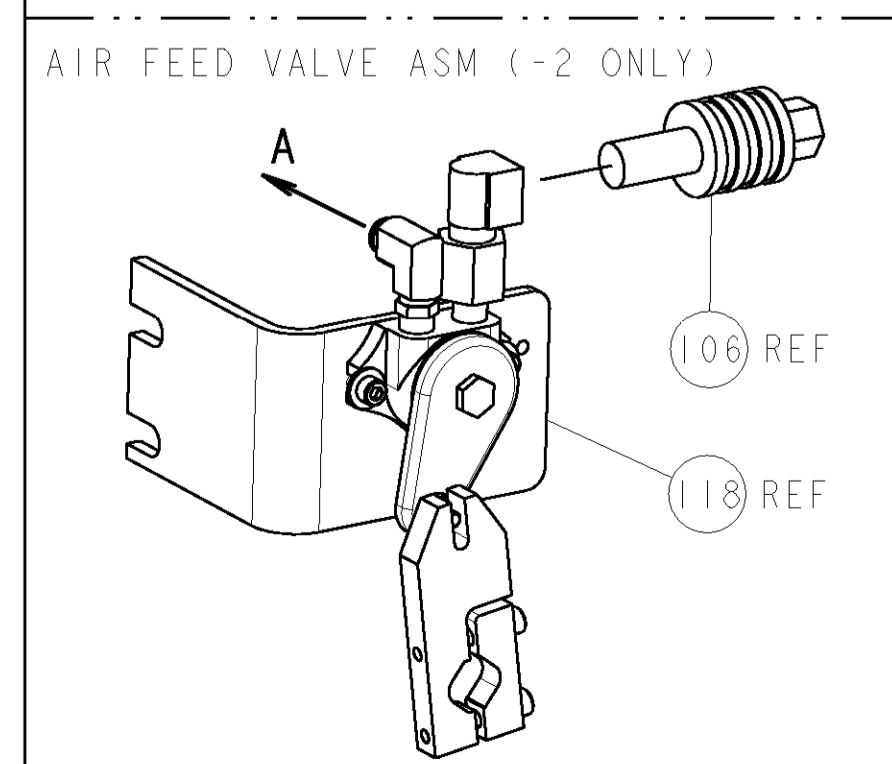

Q	PLC	TOLERANCES UNLESS OTHERWISE SPECIFIED:	FINISH	WEIGHT	CUSTOMER DRAWING
0	PLC	±			
1	PLC	±0.1			
2	PLC	±0.01			
3	PLC	±0.001			
4	PLC	±0.0001			
	ANGLES	±			