

FEATURES:

- 0.5 MICRON CMOS Technology
- Guaranteed low skew < 700ps (max.)
- Low duty cycle distortion < 1ns (max.)
- Low CMOS power levels
- TTL compatible inputs and outputs
- Rail-to-rail output voltage swing
- High drive: -24mA I_{OH}, +64mA I_{OL}
- Two independent output banks with 3-state control
- 1:5 fanout per bank
- "Heartbeat" monitor output
- Available in SSOP and SOIC packages

DESCRIPTION:

The FCT806 is an inverting buffer/clock driver built using advanced dual metal CMOS technology. Each bank consists of two banks of drivers. Each bank drives five output buffers from a standard TTL compatible input. These devices feature a "heart-beat" monitor for diagnostics and PLL driving. The MON output is identical to all other outputs and complies with the output specifications in this document.

The FCT806 offers low capacitance inputs and hysteresis. Rail-to-rail output swing improves noise margin and allows easy interface with CMOS inputs.

FUNCTIONAL BLOCK DIAGRAM

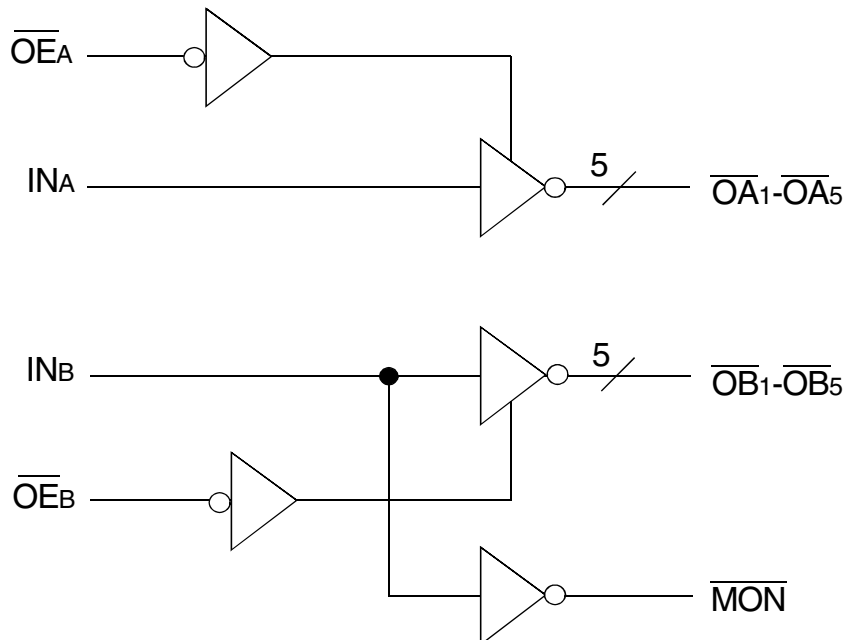

PIN CONFIGURATION

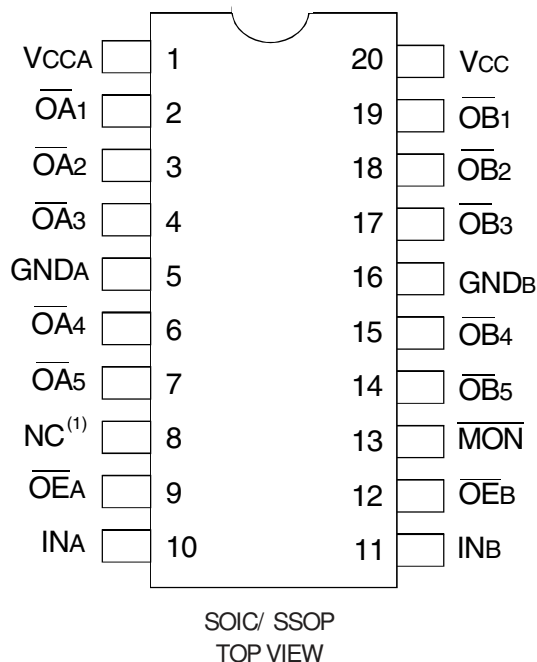

NOTE:

1. Pin 8 is not internally connected on devices with a "K" prefix in the date code. On older devices, pin 8 is internally connected to GND. To insure compatibility with all products, pin 8 should be connected to GND at the board level.

ABSOLUTE MAXIMUM RATINGS⁽¹⁾

Symbol	Description	Max	Unit
V _{TERM} ⁽²⁾	Terminal Voltage with Respect to GND	-0.5 to +7	V
V _{TERM} ⁽³⁾	Terminal Voltage with Respect to GND	-0.5 to V _{CC} +0.5	V
T _{STG}	Storage Temperature	-65 to +150	°C
I _{OUT}	DC Output Current	-60 to +120	mA

NOTES:

1. Stresses greater than those listed under ABSOLUTE MAXIMUM RATINGS may cause permanent damage to the device. This is a stress rating only and functional operation of the device at these or any other conditions above those indicated in the operational sections of this specification is not implied. Exposure to absolute maximum rating conditions for extended periods may affect reliability.
2. Input and V_{CC} terminals.
3. Output and I/O terminals.

CAPACITANCE (T_A = +25°C, f = 1.0MHz)

Symbol	Parameter ⁽¹⁾	Conditions	Typ.	Max.	Unit
C _{IN}	Input Capacitance	V _{IN} = 0V	4.5	6	pF
C _{OUT}	Output Capacitance	V _{OUT} = 0V	5.5	8	pF

NOTE:

1. This parameter is measured at characterization but not tested.

PIN DESCRIPTION

Pin Names	Description
OEA, OEB	3-State Output Enable Inputs (Active LOW)
INA, INB	Clock Inputs
OAn, OBn	Clock Outputs
MON	Monitor Output

FUNCTION TABLE (1)

Inputs		Outputs	
OEA, OEB	INA, INB	OAn, OBn	MON
L	L	H	H
L	H	L	L
H	L	Z	H
H	H	Z	L

NOTE:

1. H = HIGH
L = LOW
Z = High-Impedance

DC ELECTRICAL CHARACTERISTICS OVER OPERATING RANGE

Following Conditions Apply Unless Otherwise Specified: $V_{LC} = 0.2V$; $V_{HC} = V_{CC} - 0.2V$

Commercial: $T_A = 0^\circ C$ to $+70^\circ C$, $V_{CC} = 5V \pm 5\%$

Symbol	Parameter	Test Conditions ⁽¹⁾		Min.	Typ. ⁽²⁾	Max.	Unit
V_{IH}	Input HIGH Level	Guaranteed Logic HIGH Level		2	—	—	V
V_{IL}	Input LOW Level	Guaranteed Logic LOW Level		—	—	0.8	V
I_{IH}	Input HIGH Current	$V_{CC} = \text{Max.}$	$V_I = V_{CC}$	—	—	± 1	μA
I_{IL}	Input LOW Current	$V_{CC} = \text{Max.}$	$V_I = \text{GND}$	—	—	± 1	μA
I_{OZH}	Off State (Hi-Z) Output Current	$V_{CC} = \text{Max.}$	$V_O = V_{CC}$	—	—	± 1	μA
I_{OZL}			$V_O = \text{GND}$	—	—	± 1	
V_{IK}	Clamp Diode Voltage	$V_{CC} = \text{Min.}, I_{IN} = -18\text{mA}$		—	-0.7	-1.2	V
I_{OS}	Short Circuit Current	$V_{CC} = \text{Max.}, V_O = \text{GND}^{(3)}$		-60	-120	—	mA
V_{OH}	Output HIGH Voltage	$V_{CC} = 3V, V_{IN} = V_{LC} \text{ or } V_{HC}$ $V_{CC} = \text{Min.}$ $V_{IN} = V_{IH} \text{ or } V_{IL}$	$I_{OH} = -32\mu A$	V_{HC}	V_{CC}	—	V
			$I_{OH} = -300\mu A$	V_{HC}	V_{CC}	—	
			$I_{OH} = -15\text{mA}$	3.6	4.3	—	
			$I_{OH} = -24\text{mA}$	2.4	3.8	—	
V_{OL}	Output LOW Voltage	$V_{CC} = 3V, V_{IN} = V_{LC} \text{ or } V_{HC}$ $V_{CC} = \text{Min.}$ $V_{IN} = V_{IH} \text{ or } V_{IL}$	$I_{OL} = 300\mu A$	—	GND	V_{LC}	V
			$I_{OL} = 300\text{mA}$	—	GND	V_{LC}	
			$I_{OL} = 64\text{mA}$	—	0.3	0.55	
V_H	Input Hysteresis for all inputs	—		—	200	—	mV
I_{CC}	Quiescent Power Supply Current	$V_{CC} = \text{Max.}, V_{IN} = \text{GND} \text{ or } V_{CC}$		—	5	500	μA

NOTES:

1. For conditions shown as Max. or Min., use appropriate value specified under Electrical Characteristics for the applicable device type.
2. Typical values are at $V_{CC} = 5V$, $+25^\circ C$ ambient.
3. Not more than one output should be shorted at one time. Duration of the test should not exceed one second.

POWER SUPPLY CHARACTERISTICS

Symbol	Parameter	Test Conditions ⁽¹⁾		Min.	Typ. ⁽²⁾	Max.	Unit
ΔI_{CC}	Quiescent Power Supply Current TTL Inputs HIGH	V _{CC} = Max. V _{IN} = 3.4V ⁽³⁾		—	1	2.5	mA
I _{CCD}	Dynamic Power Supply Current ⁽⁴⁾	V _{CC} = Max. Outputs Open OEA = OEB = GND 50% Duty Cycle	V _{IN} = V _{CC} V _{IN} = GND	—	0.15	0.2	mA/MHz
I _C	Total Power Supply Current ⁽⁶⁾	V _{CC} = Max. Outputs Open f _o = 10MHz 50% Duty Cycle OEA = OEB = V _{CC} Mon. Output Toggling	V _{IN} = V _{CC} V _{IN} = GND	—	1.5	2.5	mA
			V _{IN} = 3.4V V _{IN} = GND	—	2	3.8	
		V _{CC} = Max. Outputs Open f _o = 2.5MHz 50% Duty Cycle OEA = OEB = GND Eleven Outputs Toggling	V _{IN} = V _{CC} V _{IN} = GND	—	4.1	6 ⁽⁵⁾	
			V _{IN} = 3.4V V _{IN} = GND	—	5.1	8.5 ⁽⁵⁾	

NOTES:

- For conditions shown as Max. or Min., use appropriate value specified under Electrical Characteristics for the applicable device type.
- Typical values are at V_{CC} = 5V, +25°C ambient.
- Per TTL driven input (V_{IN} = 3.4V); all other inputs at V_{CC} or GND.
- This parameter is not directly testable, but is derived for use in Total Power Supply calculations.
- Values for these conditions are examples of the I_C formula. These limits are guaranteed but not tested.
- I_C = I_{QUIESCENT} + I_{INPUTS} + I_{DYNAMIC}
 $I_C = I_{CC} + \Delta I_{CC} \cdot D_H \cdot N_T + I_{CCD} \cdot (f_o \cdot N_o)$
 I_{CC} = Quiescent Current (I_{CC1}, I_{CC2} and I_{CC3})
 ΔI_{CC} = Power Supply Current for a TTL High Input (V_{IN} = 3.4V)
 D_H = Duty Cycle for TTL Inputs High
 N_T = Number of TTL Inputs at D_H
 I_{CCD} = Dynamic Current Caused by an Input Transition Pair (HLH or LHL)
 f_o = Output Frequency
 N_o = Number of Outputs at f_o
 All currents are in milliamps and all frequencies are in megahertz.

SWITCHING CHARACTERISTICS OVER OPERATING RANGE⁽¹⁾

Symbol	Parameter	Conditions ⁽²⁾	FCT806		FCT806A		Unit
			Min.	Max.	Min.	Max.	
t _{PLH}	Propagation Delay	CL = 50pF RL = 500Ω	1.5	5.6	1.5	5.3	ns
t _{PHL}	INA to OAn, INB to OBn		—	1.5	—	1.5	ns
t _R	Output Rise Time		—	1.5	—	1.5	ns
t _F	Output Fall Time		—	1.5	—	1.5	ns
t _{SK(O)}	Output skew: skew between outputs of all banks of same package (inputs tied together)		—	0.7	—	0.7	ns
t _{SK(P)}	Pulse skew: skew between opposite transitions of same output (t _{PHL} – t _{PLH})		—	1	—	1	ns
t _{SK(PP)}	Part-to-part skew: skew between outputs of different packages at same power supply voltage, temperature, package type and speed grade		—	1.5	—	1.5	ns
t _{PZL}	Output Enable Time		1.5	8	1.5	8	ns
t _{PZH}	OEA to OAn, OEB to OBn		1.5	7	1.5	7	ns
t _{PLZ}	Output Disable Time	1.5	7	1.5	7	ns	
t _{PHZ}	OEA to OAn, OEB to OBn	1.5	7	1.5	7	ns	

NOTES:

1. Propagation delay range indicated by Min. and Max. limit is due to V_{cc}, operating temperature and process parameters. These propagation delay limits do not imply skew.
2. See test circuits and waveforms.

TEST CIRCUITS AND WAVEFORMS

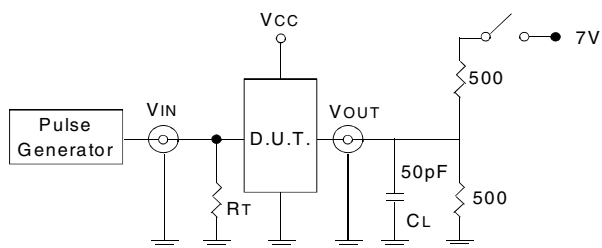

Test Circuits for All Outputs

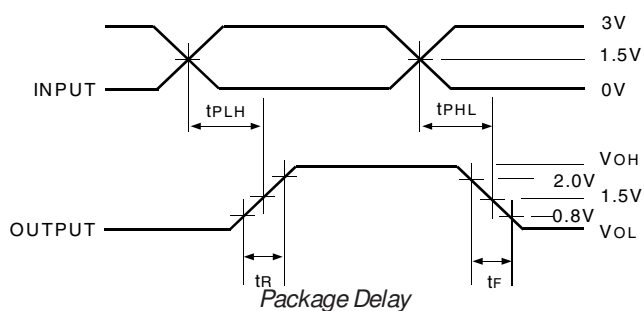

Package Delay

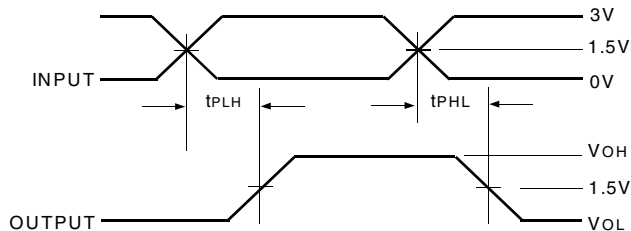

$$t_{SK(P)} = |t_{PHL} - t_{PLH}|$$

Pulse Skew - $t_{SK(P)}$

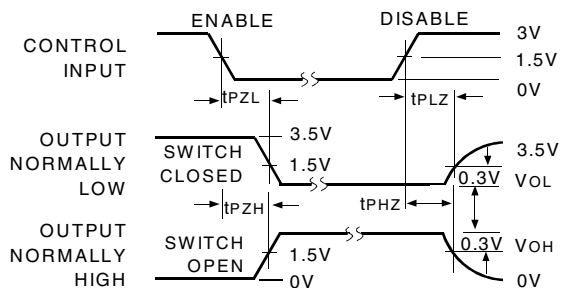

Enable and Disable Times

- NOTES:
1. Diagram shown for input Control Enable-LOW and input Control Disable-HIGH
 2. Pulse Generator for All Pulses: Rate $\leq 1.0\text{MHz}$; $t_r \leq 2.5\text{ns}$; $t_f \leq 2.5\text{ns}$

SWITCH POSITION

Test	Switch
Disable LOW Enable LOW	Closed
Disable HIGH Enable HIGH	GND

DEFINITIONS:

CL = Load capacitance: includes jig and probe capacitance.

RT = Termination resistance: should be equal to ZOUT of the Pulse Generator.

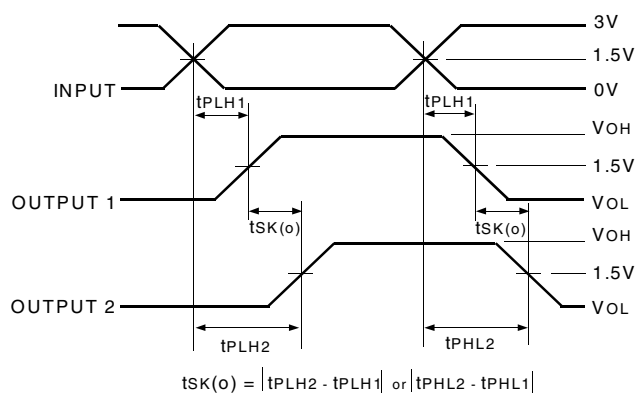

$$t_{SK(o)} = |t_{PLH2} - t_{PLH1}| \text{ or } |t_{PHL2} - t_{PHL1}|$$

Output Skew

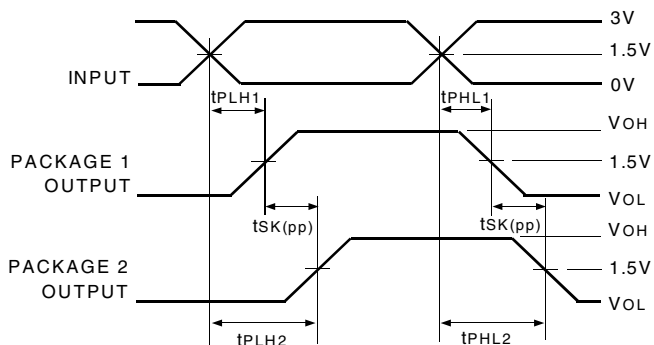

$$t_{SK(pp)} = |t_{PLH2} - t_{PLH1}| \text{ or } |t_{PHL2} - t_{PHL1}|$$

Part-to-Part Skew - $t_{SK(PP)}$

NOTE:

1. Package 1 and Package 2 are same device type and speed grade.

ORDERING INFORMATION

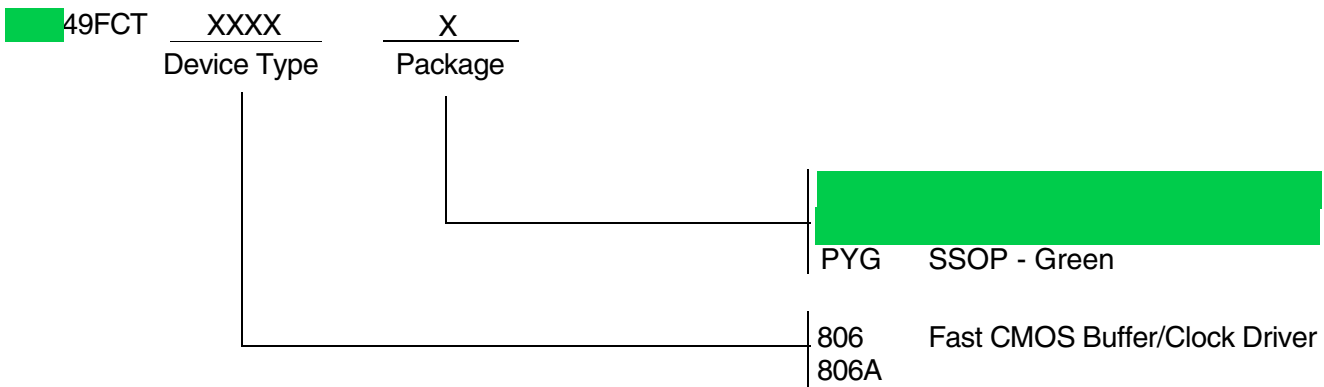

IMPORTANT NOTICE AND DISCLAIMER

RENESAS ELECTRONICS CORPORATION AND ITS SUBSIDIARIES (“RENESAS”) PROVIDES TECHNICAL SPECIFICATIONS AND RELIABILITY DATA (INCLUDING DATASHEETS), DESIGN RESOURCES (INCLUDING REFERENCE DESIGNS), APPLICATION OR OTHER DESIGN ADVICE, WEB TOOLS, SAFETY INFORMATION, AND OTHER RESOURCES “AS IS” AND WITH ALL FAULTS, AND DISCLAIMS ALL WARRANTIES, EXPRESS OR IMPLIED, INCLUDING, WITHOUT LIMITATION, ANY IMPLIED WARRANTIES OF MERCHANTABILITY, FITNESS FOR A PARTICULAR PURPOSE, OR NON-INFRINGEMENT OF THIRD PARTY INTELLECTUAL PROPERTY RIGHTS.

These resources are intended for developers skilled in the art designing with Renesas products. You are solely responsible for (1) selecting the appropriate products for your application, (2) designing, validating, and testing your application, and (3) ensuring your application meets applicable standards, and any other safety, security, or other requirements. These resources are subject to change without notice. Renesas grants you permission to use these resources only for development of an application that uses Renesas products. Other reproduction or use of these resources is strictly prohibited. No license is granted to any other Renesas intellectual property or to any third party intellectual property. Renesas disclaims responsibility for, and you will fully indemnify Renesas and its representatives against, any claims, damages, costs, losses, or liabilities arising out of your use of these resources. Renesas' products are provided only subject to Renesas' Terms and Conditions of Sale or other applicable terms agreed to in writing. No use of any Renesas resources expands or otherwise alters any applicable warranties or warranty disclaimers for these products.

(Disclaimer Rev.1.0 Mar 2020)

Corporate Headquarters

TOYOSU FORESIA, 3-2-24 Toyosu,
Koto-ku, Tokyo 135-0061, Japan
www.renesas.com

Contact Information

For further information on a product, technology, the most up-to-date version of a document, or your nearest sales office, please visit:
www.renesas.com/contact/

Trademarks

Renesas and the Renesas logo are trademarks of Renesas Electronics Corporation. All trademarks and registered trademarks are the property of their respective owners.