

Demonstration System EPC9112 Quick Start Guide

*6.78 MHz, ZVS Class-D Wireless Power System
using EPC2007C / EPC2038*



DESCRIPTION

The EPC9112 wireless power demonstration system is a high efficiency, A4WP compatible, Zero Voltage Switching (ZVS), Voltage Mode class-D wireless power transfer demonstration kit capable of delivering up to 35 W into a DC load while operating at 6.78 MHz (Lowest ISM band). The purpose of this demonstration system is to simplify the evaluation process of wireless power technology using eGaN® FETs.

The EPC9112 wireless power system comprises the three boards (shown in Figure 1) namely:

- 1) A Source Board (Transmitter or Power Amplifier) EPC9507
- 2) A Class 3 A4WP compliant Source Coil (Transmit Coil)
- 3) A Category 3 A4WP compliant Device Coil with rectifier and DC smoothing capacitor.

The amplifier board features the EPC2007C and EPC2038 enhancement mode field effect transistors (FET) in an optional half-bridge topology (single ended configuration) or default full-bridge topology (differential configuration), and includes the gate driver/s and oscillator that ensures operation of the system at 6.78 MHz. This revision of the wireless demonstration amplifier includes a synchronous bootstrap FET supply for the upper FETs of the ZVS class-D amplifier that eliminates the reverse recovery losses of the gate driver's internal bootstrap diode that dissipates energy in the upper FET. This circuit has been implemented using the new EPC2038 eGaN FET specifically designed for this function. To learn more about the synchronous bootstrap supply please refer to the following [1, 2, 3]. The EPC9507 amplifier board can also be operated using an external oscillator or by using the included new ultra low power Diashinku oscillator.

This revision can operate in either Single ended or Differential mode by changing a jumper setting. This allows for high efficiency operation with load impedance ranges that allow for single ended operation.

Finally, the timing adjust circuits for the ZVS class-D amplifiers have been separated to further ensure highest possible efficiency setting and includes separate ZVS tank circuits.

- [1] [Wireless Power Handbook](#)
- [2] [Performance Comparison for A4WP Class-3 Wireless Power Compliance between eGaN FET and MOSFET in a ZVS class-D Amplifier](#)
- [3] [EPC2038 datasheet](#)

The amplifier board is equipped with a pre-regulator that limits the DC current of the supply to the amplifier. As the amplifier draws more current, which can be due to the absence of a device coil, the pre-regulator will reduce the voltage being supplied to the amplifier that will ensure a safe operating point. The pre-regulator also monitors the temperature of the main amplifier FETs and will reduce current if the temperature exceeds 85°C. The pre-regulator can be bypassed to allow testing with custom control hardware. The board further allows easy access to critical measurement nodes that allow accurate power measurement instrumentation hookup. A simplified diagram of the amplifier board is given in Figure 1.

The Source and Device Coils are Alliance for Wireless Power (A4WP) compliant and have been pre-tuned to operate at 6.78 MHz with the EPC9507 amplifier. The source coil is class 3 and the device coil is category 3 compliant.

The device board includes a high frequency schottky diode based full bridge rectifier and output filter to deliver a filtered unregulated DC voltage. The device board comes equipped with two LED's, one green to indicate the power is being received with an output voltage equal or greater than 4 V and a second red LED that indicates that the output voltage has reached the maximum and is above 37 V.

For more information on the EPC2007C or EPC2038 eGaN FET please refer to the datasheet available from EPC at www.epc-co.com. The datasheet should be read in conjunction with this quick start guide.

The Source coil used in this wireless power transfer demo system is provided by NuCurrent (nucurrent.com). Reverse Engineering of the Source coil is prohibited and protected by multiple US and international patents. For additional information on the source coil, please contact NuCurrent direct or EPC for contact information.

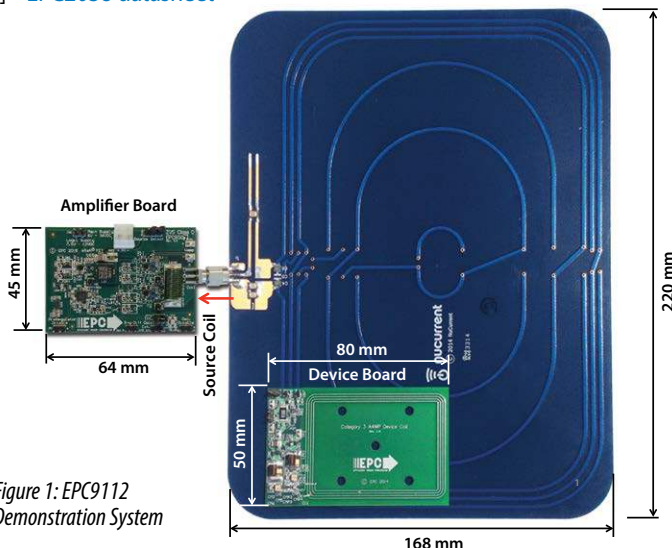

Figure 1: EPC9112 Demonstration System

Table 1: Performance Summary (T_A = 25 °C) EPC9507

Symbol	Parameter	Conditions	Min	Max	Units
V _{DD}	Control Supply Input Range		7	12	V
V _{IN}	Bus Input Voltage Range – Pre-Regulator Mode		8	36	V
V _{IN}	Bus Input Voltage Range – Bypass Mode		0	80	V
V _{OUT}	Switch Node Output Voltage			V _{IN} - 2V	V
I _{OUT}	Switch Node Output Current (ea.)			6*	A
V _{extosc}	External Oscillator Input Threshold	Input 'Low'	-0.3	0.8	V
		Input 'High'	2.4	5	V
V _{Pre_Disable}	Pre-regulator Disable Voltage Range	Open drain/collector	-0.3	5.5	V
I _{Pre_Disable}	Pre-regulator Disable Current	Open Drain/Collector	-1	1	mA
V _{Osc_Disable}	Oscillator Disable Voltage Range	Open Drain/Collector	-0.3	5	V
I _{Osc_Disable}	Oscillator Disable Current	Open Drain/Collector	-25	25	mA

* Assumes inductive load, maximum current depends on die temperature – actual maximum current will be subject to switching frequency, bus voltage and thermals.

Table 2: Performance Summary (T_A = 25 °C) Category 3 Device Board

Symbol	Parameter	Conditions	Min	Max	Units
V _{OUT}	Output Voltage Range		0	38	V
I _{OUT}	Output Current Range		0	1.5#	A

Actual maximum current subject to operating temperature limits

MECHANICAL ASSEMBLY

The assembly of the EPC9112 Wireless Demonstration kit is simple and shown in Figure 1. The source coil and amplifier have been equipped with reverse polarity SMA connectors. The source coil is simply connected to the amplifier.

The device board does not need to be mechanically attached to the source coil.

DESCRIPTION

The Amplifier Board (EPC9507)

Figure 1 shows a diagram of the EPC9507 ZVS class-D amplifier with pre-regulator. The pre-regulator is set to a specified DC current limit (up to 1.5 A) by adjusting P49 and operates from 8 V through 36 V input. The output voltage of the pre-regulator is limited to approximately 2 V below the input voltage. The pre-regulator can be bypassed by moving the jumper (JP60) over from the right 2 pins to the left 2 pins. To measure the current the amplifier is drawing, an ammeter can be inserted in place of the jumper (JP60) in the location based on the operating mode (pre-regulator or bypass).

The amplifier comes with its own oscillator that is pre-programmed to 6.78 MHz \pm 678 Hz. It can be disabled by placing a jumper into J70 or can be externally shutdown using an externally controlled open collector / drain transistor on the terminals of J70 (note which is the ground connection). The switch needs to be capable of sinking at least 25 mA. An external oscillator can be used instead of the internal oscillator when connected to J71 (note which is the ground connection) and the jumper (JP70) is moved from the right 2 pins to the left 2 pins.

The pre-regulator can also be disabled in the same manner as the oscillator using J51. The pre-regulator can be bypassed, to increase the operating voltage (with no current or thermal protection) to the amplifier or to use an external regulator, by moving the jumper JP60 from the right 2 pins to the left 2 pins. Jumper JP60 can also be used to connect an ammeter to measure the current drawn by the amplifier (make sure the ammeter connects to the pins that correspond to the mode of operation either bypass or pre-regulator).

Single Ended Operation Hardware implementation

The amplifier can be configured for single ended operation where only devices Q1 and Q2 are used. In this mode only L_{ZVS1} and C_{ZVS} are used to establish ZVS operation. If a permanent single ended configuration is required and Q11 and Q12 are populated, then the following changes need to be made to the board:

- 1) Remove R77 and R78 OR P77 and P78
- 2) Short out C42_2 and C43_2
- 3) Short the connection of JMP1 (back side of the board)
- 4) Remove L_{ZVS12} (if populated)
- 5) Add L_{ZVS2} (390 nH)
- 6) Check that C_{ZVS2} is populated, if not then install.
- 7) R71 and R72 may need to be adjusted for the new operating condition to achieve maximum efficiency (see section on ZVS timing adjustment).

ZVS Timing Adjustment

Setting the correct time to establish ZVS transitions is critical to achieving high efficiency with the EPC9507 amplifier. This can be done by selecting the values for R71, R72, R77, and R78 respectively. This procedure is best performed using potentiometers P71, P72, P77, and P78 installed that is used to determine the fixed resistor values. The procedure is the same for both single ended and differential mode of operation (as applicable per operating mode). The timing MUST initially be set WITHOUT the source coil connected to the amplifier. The timing diagrams are given in Figure 4 and should be referenced when following this procedure. Only perform these steps if changes have been made to the board as it is shipped preset.

The steps are:

1. Remove the jumper in JP60 and insert it into J51 to place the EPC9507 amplifier in bypass mode. With power off connect the main input power supply (+) bus to the center pin of JP60 (pin 2) and the ground of the main power to the ground (-) connection of J50 - V_{IN} .
2. With power off, connect the control input power supply bus to + V_{DD} (J90). Note the polarity of the supply connector.
3. Connect a LOW capacitance oscilloscope probe to the probe-hole J2 between the two eGaN FETs Q10_x and Q11_x and lean against the ground post as shown in Figure 3.
4. Turn on the control supply – make sure the supply is between 7 V and 12 V range (7.5 V is recommended).
5. Turn on the main supply voltage to the required predominant operating value (such as 24 V but NEVER exceed the absolute maximum voltage of 36 V).
6. While observing the oscilloscope adjust P71 or P77 for the rising edge of the waveform so achieve the green waveform of figure 4. Repeat for the falling edge of the waveform by adjusting P72 or P78. Repeat for the other eGaN FET pair if using differential mode operation.
7. Check that the setting remains optimal with a source coil attached. In this case it is important that the source coil is TUNED to resonance WITH an applicable load. Theoretically the settings should remain unchanged. Adjust if necessary.
8. Replace the potentiometers with fixed value resistors. Configure the EPC9507 amplifier back to normal operation by removing the power connections to J50 and JP60, removing the jumper in J51 and inserting it back into JP60 (right 2 pins 2 & 3).

Determining Component Values for L_{zvs}

The ZVS tank circuit is not operated at resonance, and only provides the necessary negative device current for self-commutation of the output voltage at turn off. The capacitance C_{ZVS} is chosen to have a very small ripple voltage component and is typically around 1 μ F. The amplifier supply voltage, switch-node transition time will determine the value of inductance for L_{ZVSx} which needs to be sufficient to maintain ZVS operation over the DC device load resistance range and coupling between the device and source coil range and can be calculated using the following equation:

$$L_{ZVS} = \frac{\Delta t_{vt}}{8 \cdot f_{sw} \cdot C_{OSSQ}} \quad (1)$$

Where:

- Δt_{vt} = Voltage transition time [s]
- f_{sw} = Operating frequency [Hz]
- C_{OSSQ} = Charge equivalent device output capacitance [F].

Note that the amplifier supply voltage V_{AMP} is absent from the equation as it is accounted for by the voltage transition time. The charge equivalent capacitance can be determined using the following equation:

$$C_{OSSQ} = \frac{1}{V_{AMP}} \cdot \int_0^{V_{AMP}} C_{OSS}(v) \cdot dv \quad (2)$$

To add additional immunity margin for shifts in coil impedance, the value of L_{ZVS} can be decreased to increase the current at turn off of the devices (which will increase device losses). Typical voltage transition times range from 2 ns through 12 ns. For the differential case the voltage and charge (C_{OSSQ}) are doubled.

QUICK START PROCEDURE

The EPC9112 demonstration system is easy to set up and evaluate the performance of the eGaN FET in a wireless power transfer application. Refer to Figure 1 to assemble the system and Figures 5 and 7 for proper connection and measurement setup before following the testing procedures.

The EPC9507 can be operated using any one of two alternative methods:

- a. Using the pre-regulator
- b. Bypassing the pre-regulator

a. Operation using the pre-regulator

The pre-regulator is used to supply power to the amplifier in this mode and will limit the DC current to the amplifier based on the setting. The pre-regulator also monitors the temperature of the amplifier and will limit the current in the event the temperature exceeds 85°C.

1. Make sure the entire system is fully assembled prior to making electrical connections and make sure jumper (JP60 is set to pre-regulator – right 2 pins).
2. With power off, connect the main input power supply bus to $+V_{IN}$ (J50). Note the polarity of the supply connector.
3. With power off, connect the control input power supply bus to $+V_{DD}$ (J90). Note the polarity of the supply connector.
4. Select and connect an applicable load resistance to the device board.
5. Make sure all instrumentation is connected to the system.
6. Turn on the control supply – make sure the supply is between 7 V and 12 V (7.5 V is recommended).
7. Turn on the main supply voltage to the required value (it is recommended to start at 8 V and do not exceed the absolute maximum voltage of 32 V).

The Source Coil

Figure 3 shows the schematic for the source coil which is Class 3 A4WP compliant. The matching network includes both series and shunt tuning. The matching network series tuning is differential to allow balanced connection and voltage reduction for the capacitors.

The Device Board

Figure 4 shows the basic schematic for the device coil which is Category 3 A4WP compliant. The matching network includes both series and shunt tuning. The matching network series tuning is differential to allow balanced connection and voltage reduction for the capacitors.

The device board comes equipped with a kelvin connected output DC voltage measurement terminal and a built in shunt to measure the output DC current.

Two LEDs have been provided to indicate that the board is receiving power with an output voltage greater than 4 V (green LED) and that the board output voltage limit has been reached (greater than 36 V using the red LED).

8. Once operation has been confirmed, adjust the main supply voltage within the operating range and observe the output voltage, efficiency and other parameters on both the amplifier and device boards.
9. For shutdown, please follow steps in the reverse order. Start by reducing the main supply voltage to 0 V followed by steps 6 through 2.

b. Operation bypassing the pre-regulator

In this mode, the pre-regulator is bypassed and the main power is connected directly to the amplifier. This allows the amplifier to be operated using an external regulator or to test at higher voltages.

In this mode there is no current or thermal protection for the eGaN FETs.

1. Make sure the entire system is fully assembled prior to making electrical connections and remove the jumper JP60 and insert it into J51 to place the EPC9507 amplifier in bypass mode. Never connect the main power positive (+) to J50 when operating in bypass mode.
2. With power off, connect the main input power supply ground to the ground terminal of J50 (-) and the positive (+) to the center pin of JP60.
3. With power off, connect the control input power supply bus to $+V_{DD}$ (J90). Note the polarity of the supply connector.
4. Select and connect an applicable load resistance to the device board.
5. Make sure all instrumentation is connected to the system.
6. Turn on the control supply – make sure the supply is between 7 V and 12 V range (7.5 V is recommended).
7. Turn on the main supply voltage to the required value (it is recommended to start at 2 V and do not exceed the absolute maximum voltage of 80 V).

8. Once operation has been confirmed, adjust the main supply voltage within the operating range and observe the output voltage, efficiency and other parameters on both the amplifier and device boards. See Pre-Cautions when operating in the bypass mode

9. For shutdown, please follow steps in the reverse order. Start by reducing the main supply voltage to 0 V followed by steps 6 through 2.

NOTE. When measuring the high frequency content switch-node (Source Coil Voltage), care must be taken to avoid long ground leads. An oscilloscope probe connection (preferred method) has been built into the board to simplify the measurement of the Source Coil Voltage (J2 and J3 as shown in Figure 3).

SWITCHING BETWEEN SINGLE-ENDED AND DIFFERENTIAL MODE OPERATION

The ZVS class-D amplifier can be operated in either single-ended or differential mode operation by changing the jumper setting of J75. When inserted the amplifier operates in the single-ended mode. Using an external pull down with floating collector/ drain connection will have the same effect. The external transistor must be capable of sinking 25 mA and withstand at least 6 V.

THERMAL CONSIDERATIONS

The EPC9112 demonstration system showcases the EPC2007C and EPC2038 eGaN FETs in a wireless energy transfer application. Although the electrical performance surpasses that of traditional silicon devices,

their relatively smaller size does magnify the thermal management requirements. The operator must observe the temperature of the gate driver and eGaN FETs to ensure that both are operating within the thermal limits as per the datasheets.

NOTE. The EPC9112 demonstration system has limited current and thermal protection only when operating off the Pre-Regulator. When bypassing the pre-regulator there is no current or thermal protection on board and care must be exercised not to over-current or over-temperature the devices. Wide coil coupling and load range variations can lead to increased losses in the devices.

Pre-Cautions

The EPC9112 demonstration system has no controller or enhanced protections systems and therefore should be operated with caution. Some specific precautions are:

1. Never operate the Source Coil within 6 inches in any direction of any solid metal objects as this will shift the tuning of the coil. Please contact EPC should the tuning of the coil be required to change to suit specific conditions so that it can be correctly adjusted for use with the ZVS class-D amplifier.
2. There is no heat-sink on the devices and during experimental evaluation it is possible present conditions to the amplifier that may cause the devices to overheat. Always check operating conditions and monitor the temperature of the EPC devices using an IR camera.

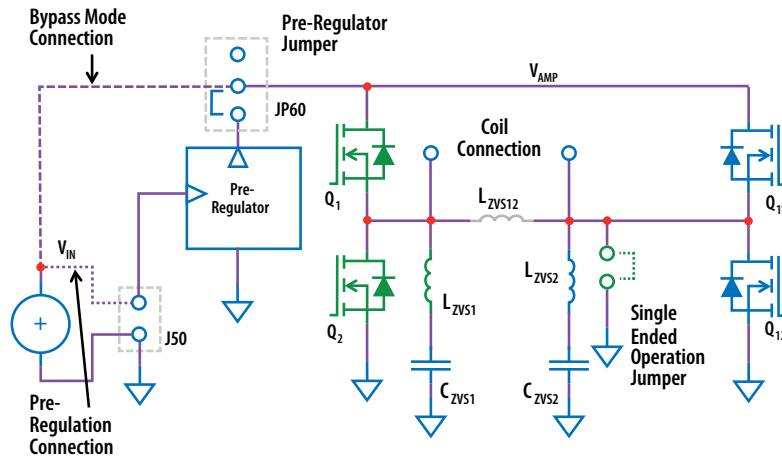

Figure 2: Diagram of EPC9507 Amplifier Board

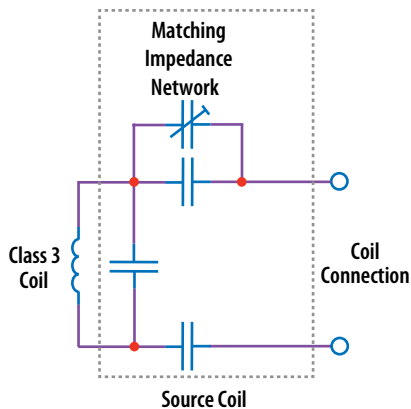

Figure 3: Diagram of the A4WP Class 3 Source Coil

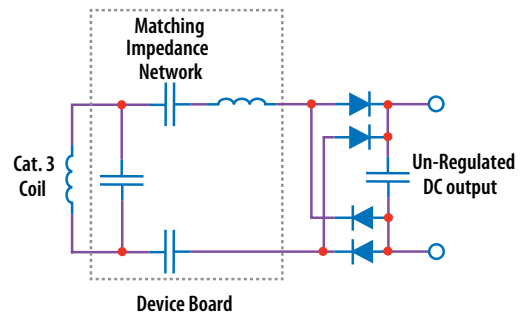

Figure 4: Basic Schematic of the A4WP Category 3 Device Board

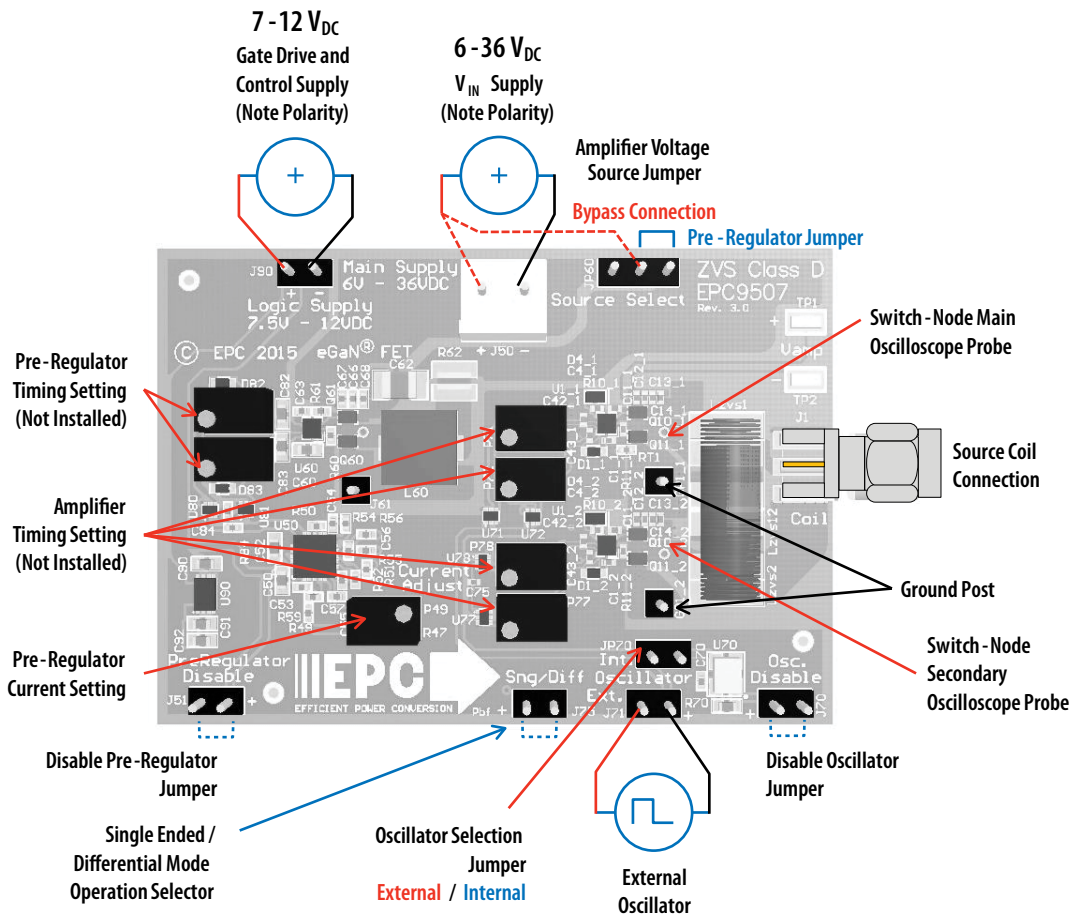

Figure 5: Proper Connection and Measurement Setup for the Amplifier Board

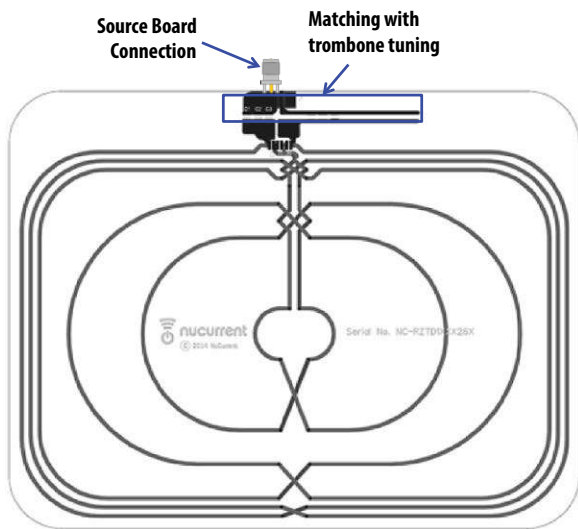

Figure 6: Proper Connection for the Source Coil

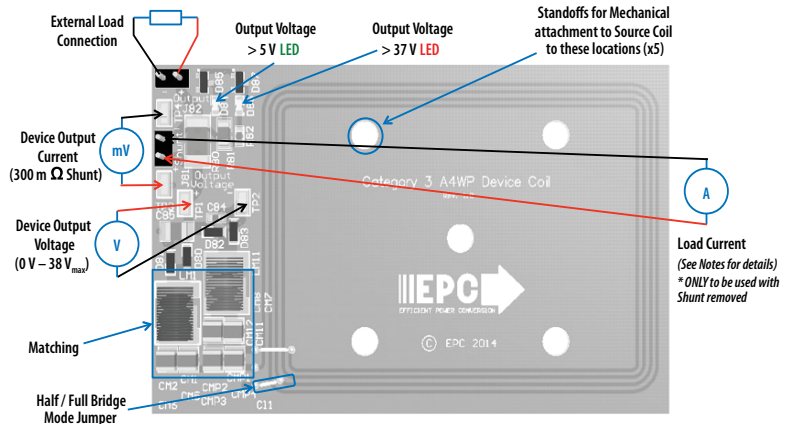

Figure 7: Proper Connection and Measurement Setup for the Device Board

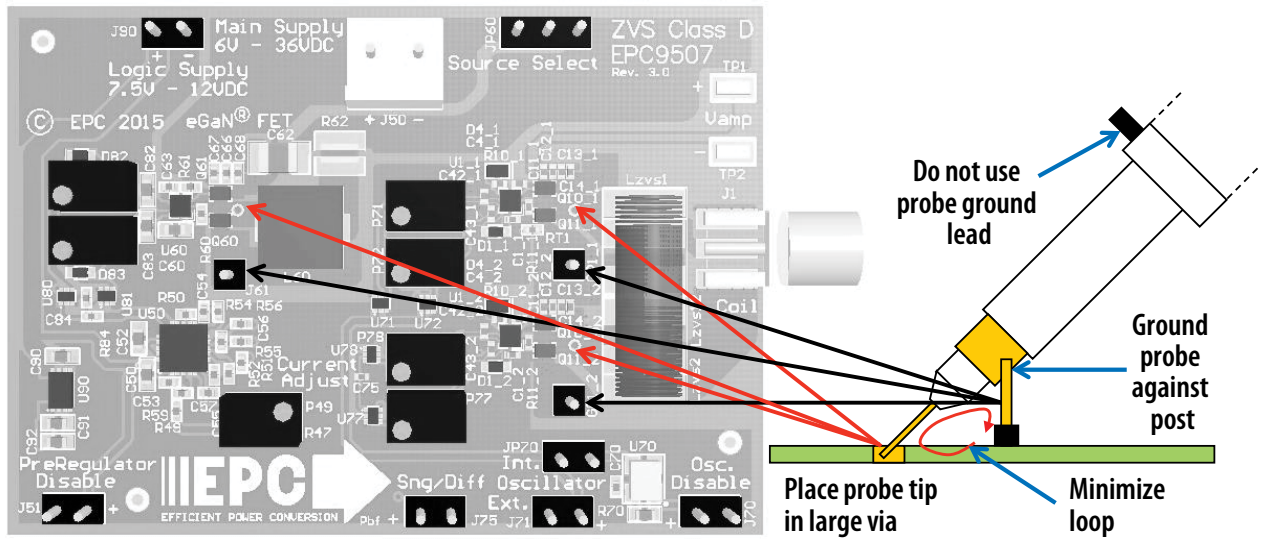

Figure 8 : Proper Measurement of the Switch Nodes Using the Hole and Ground Post

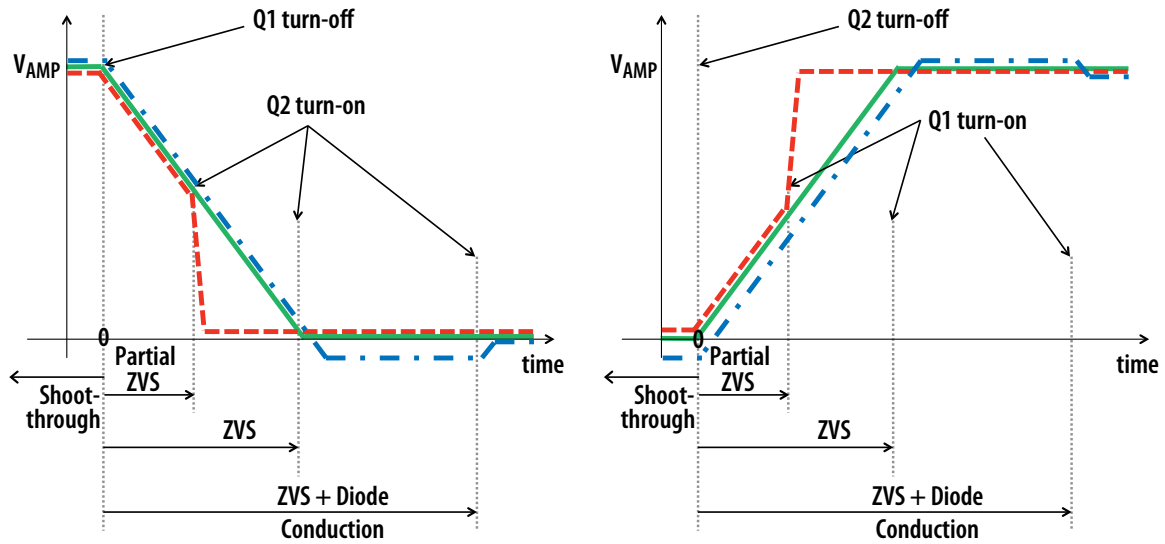

Figure 9: ZVS Timing Diagrams

Table 3: Bill of Materials - Amplifier Board

Item	Qty	Reference	Part Description	Manufacturer	Part Number
1	2	C1_1, C1_2	4.7 μ F, 10 V	Samsung	CL05A475MP5NRNC
2	4	C2_1, C2_2, C4_1, C4_2	100 nF, 25 V	Murata	GRM155R71C104KA88D
3	2	C5_1, C5_2	DNP	Murata	GRM155R71C104KA88D
4	2	C3_1, C3_2	22 nF, 25 V	TDK	C1005X7R1E223K050BB
5	8	C11_1, C11_2, C12_1, C12_2, C13_1, C13_2, C14_1, C14_2	10 nF, 100 V	TDK	C1005X7S2A103K050BB
6	7	C15_1, C15_2, C16_1, C16_2, C62, C64, C65	2.2 μ F 100 V	Taiyo Yuden	HMK325B7225KN-T
7	5	C42_1, C42_2, C43_1, C43_2, C75	22 pF, 50 V	Kemet	C0402C220J5GACTU
8	1	C50	1 μ F, 50 V	Taiyo Yuden	UMK107AB7105KA-T
9	2	C52, C60	4.7 μ F, 16 V	TDK	C1608X5R1C475K
10	2	C53, C54	2.2 nF, 50 V	Yageo	CC0402KRX7R9BB222
11	4	C55, C66, C67, C68	10 nF, 100 V	TDK	C1005X7S2A103K050BB
12	1	C56	1 nF, 50 V	Yageo	CC0402KRX7R9BB102
13	3	C57, C63, C70	100 nF, 25 V	TDK	C1005X7R1E104K050BB
14	6	C71, C72, C77, C78, C80, C81	100 nF, 25 V	TDK	C1608X7R1E104K
15	1	C73	22 pF, 25 V	DNP	DNP
16	2	C82, C83	100 pF, 25 V	TDK	C1608C0G1H101J080AA
17	1	C84	47 pF, 50 V	Yageo	CC0402JRNPO9BN470
18	3	C90, C91, C92	1 μ F, 25 V	TDK	C1608X7R1E105K
19	2	Czvs1, Czvs2	1 μ F, 50 V	Taiyo Yuden	C2012X7R1H105K125AB
20	2	D1_1, D1_2	40 V, 300 mA	ST	BAT54KFILM
21	10	D2_1, D2_2, D71, D72, D77, D78, D82, D83	40 V, 30 mA	Diodes Inc.	SDM03U40
22	2	D3_1, D3_2	DNP	Diodes Inc.	SDM03U40
23	2	D4_1, D4_2	5 V 1, 150 mW	Bournes	CD0603-Z5V1
24	3	GP1_1, GP1_2, J61	.1 Male Vert.	Würth	61300111121
25	1	J1	SMA Board Edge	Linx	CONREVSMA013.062
26	1	J50	.156 Male Vert.	Würth	645002114822
27	6	J51, J70, J71, J75, J90, JP70	.1 Male Vert.	Würth	61300211121
28	1	JMP1	DNP		
29	1	JP60	.1 Male Vert.	Würth	61300311121
30	1	JP61	Jumper 100	Würth	60900213421
31	1	L60	10 μ H	Würth	744314101
32	2	Lzvs1, Lzvs2	DNP	CoilCraft	DNP
33	1	Lzvs12	500 nH	CoilCraft	2929SQ-501JEB
34	6	P71, P72, P77, P78, P82, P83	DNP	Murata	PV37Y102C01B00
35	1	P49	DNP	Murata	PV37Y103C01B00
36	2	Q4_1, Q4_2	100 V, 2.8 Ω	EPC	EPC2038
37	6	Q10_1, Q10_2, Q11_1, Q11_2, Q60, Q61	100 V, 6 A, 30 mW	EPC	EPC2007C
38	2	R2_1, R2_2	20 Ω	Stackpole	RMCF0402JT20R0
39	2	R3_1, R3_2	27 k Ω	Panasonic	ERJ-2GEJ273X
40	2	R4_1, R4_2	4.7 Ω	Stackpole	RMCF0402FT4R70
41	4	R10_1, R10_2, R11_1, R11_2	2.2 Ω	Yageo	RC0402JR-072R2L
42	1	R47	6.04 k Ω	Panasonic	ERJ-2RKF6041X
43	1	R48	2.74 k Ω	Panasonic	ERJ-2RKF2741X
44	1	R49	3.3 k Ω	Panasonic	ERJ-2RKF3301X
45	1	R50	40.2k Ω	Yageo	RC0402FR-0740K2L
46	1	R51	280 k Ω	Panasonic	ERJ-2RKF2803X
47	1	R52	10 k Ω	Yageo	RC0402FR-0710K1L
48	1	R54	15 k Ω	Yageo	RC0402JR-0715K1L
49	3	R55, R56, R84	10 Ω	Yageo	RC0402FR-0710R1L
50	1	R57	909 k Ω	Panasonic	ERJ-3EKF9093V
51	1	R58	300 k Ω	Panasonic	ERJ-2RKF3003X
52	1	R59	45.3 k Ω	Panasonic	ERJ-2RKF4532X
53	2	R60, R61	2.2 Ω	Yageo	RC0402JR-072R2L
54	1	R62	24 mW, 1 Ω	Susumu	PRL1632-R024-F-T1

(continued on next page)

Table 3: Bill of Materials - Amplifier Board (continued)

Item	Qty	Reference	Part Description	Manufacturer	Part Number
55	1	R70	47 k Ω	Stackpole	RMCF0603JT47K0
56	2	R71, R78	390 Ω	Stackpole	RMCF0603FT390R
57	2	R72, R77	124 Ω	Panasonic	ERJ-3EKF1240V
58	1	R73	10 k Ω	Yageo	RC0603JR-0710KL
59	1	R75	10 k Ω	Panasonic	ERJ-2GEJ103X
60	1	R82	31.6 Ω	Panasonic	ERJ-3EKF31R6V
61	1	R83	191 Ω	Panasonic	ERJ-3EKF1910V
62	1	RT1	470 k Ω @ 25°C	Murata	NCP15WM474E03RC
63	2	TP1, TP2	SMD Probe Loop	Keystone	5015
64	3	U1_1, U1_2, U60	100 V eGaN Driver	National Semiconductor	LM5113TM
65	1	U50	Step Down Controller	Linear	LT3741EMF#PBF
66	1	U70	Programmable Oscillator	KDS Daishinku America	DSO221SHF 6.780 / 1XSF006780EH
67	3	U71, U77, U81	2 In NAND	Fairchild	NC7SZ00L6X
68	3	U72, U78, U80	2 In AND	Fairchild	NC7SZ08L6X
69	1	U90	5.0 V, 250 mA DFN	Microchip	MCP1703T-5002E/MC

EPC would like to acknowledge Würth Electronics (www.we-online.com/web/en/wuerth_elektronik/start.php) and KDS Daishinku America (www.kdsamerica.com) for their support of this project.

Table 4: Bill of Materials - Source Coil

Item	Qty	Reference	Part Description	Manufacturer	Part Number
1	1	Ctrombone	680 pF, 300 V	Vishay	VJ1111D681KXDAR
2	1	C1	DNP	—	—
3	1	C2	15 pF, 1500 V	Vishay	VJ1111D150JXRAJ
4	1	C3	560 pF, 300 V	Vishay	VJ1111D561KXDAR
5	1	PCB1	Class 3 Coil Former	NuCurrent	R26_RZTX_D1
6	2	C4, C6	0 Ω, 0612	Vishay	RCL06120000Z0EA
7	1	C5	DNP	—	—
8	1	J1	SMA PCB Edge	Linx	CONREV SMA003.031

Table 5: Bill of Materials - Device Board

Item	Qty	Reference	Part Description	Manufacturer	Part Number
1	1	C84	100 nF, 50 V	Murata	GRM188R71H104KA93D
2	1	C85	10 μF, 50 V	Murata	GRM32DF51H106ZA01L
3	1	PCB1	Cat3PRU	Coastal Circuits	Cat3DeviceBoard
4	2	CM1, CM11	300 pF	Vishay	VJ1111D301KXLAT
5	4	CM2, CM12, CMP1, CMP2	DNP	Vishay	VJ1111D101JXRAT, VJ1111D560JXRAJ
6	3	CM5, CM7, CMP3	DNP	Vishay	VJ0505D101JXCAJ
7	2	CM6, CM8	56 pF	Vishay	VJ0505D560JXPAJ
8	1	CMP4	100 pF	Vishay	VJ0505D101JXCAJ
9	4	D80, D81, D82, D83	40 V, 1 A	Diodes Inc.	PD3S140-7
10	1	D84	LED 0603 Green	Lite-On	LTST-C193KGKT-5A
11	1	D85	2.7 V 250 mW	NXP	BZX84-C2V7,215
12	1	D86	LED 0603 Red	Lite-On	LTST-C193KRKT-5A
13	1	D87	33 V, 250 mW	NXP	BZX84-C33,215
14	2	J81, J82	.1" Male Vert.	Würth	61300211121
15	2	LM1, LM11	82 nH	Würth	744912182
16	1	R80	300 mΩ, 1 W	Stackpole	CSRN2512FKR300
17	1	R81	4.7k Ω	Stackpole	RMCF1206FT4K70
18	1	R82	422 Ω	Yageo	RMCF0603FT422R
19	4	TP1, TP2, TP3, TP4	SMD Probe Loop	Keystone	5015
20	1	JPR1	Wire Jumper at CM11	—	—

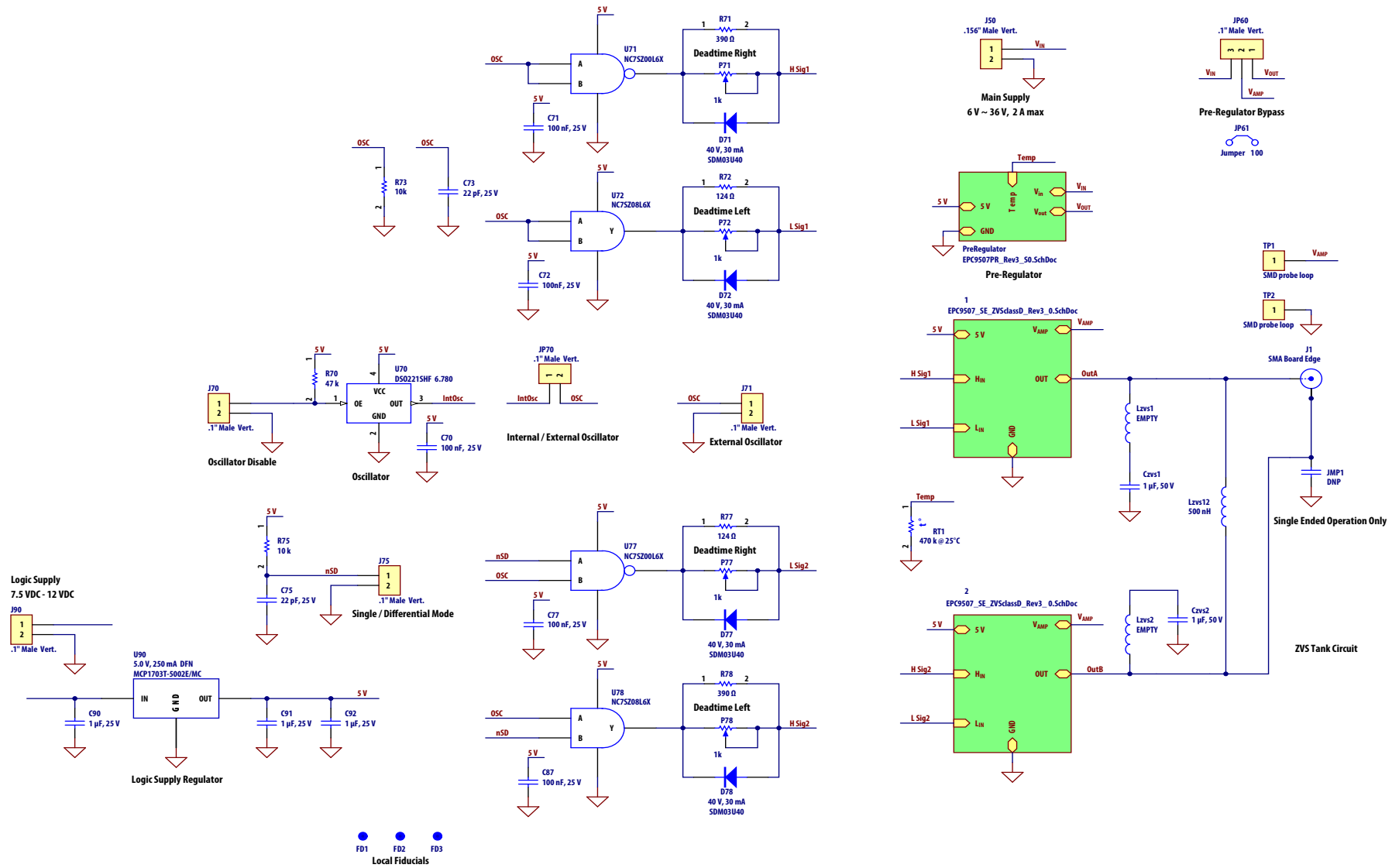

Figure 10: Differential ZVS Class D Wireless Power Source Board using EPC2014C

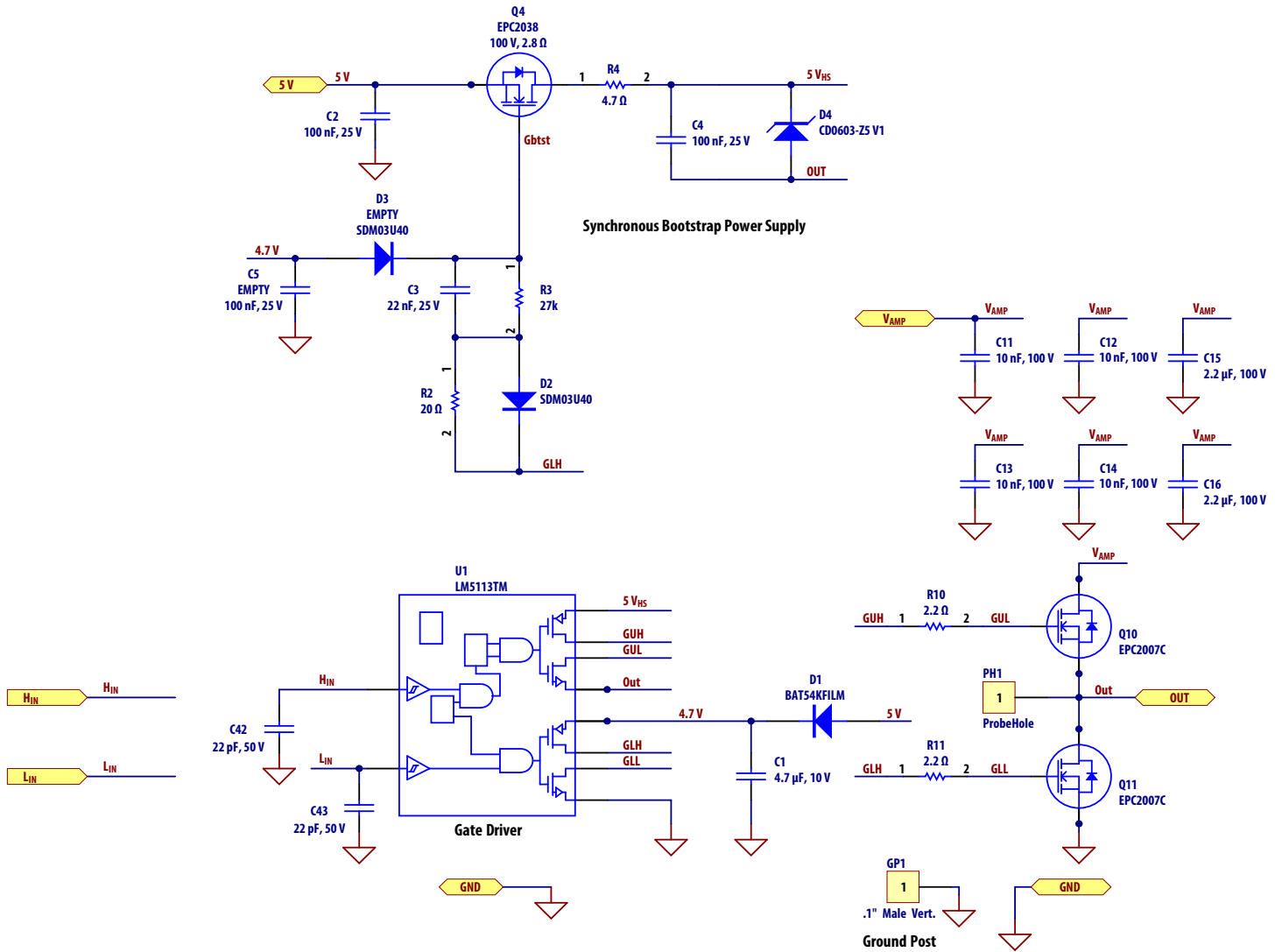

Figure 11: Single Ended, High Efficiency ZVS Class D

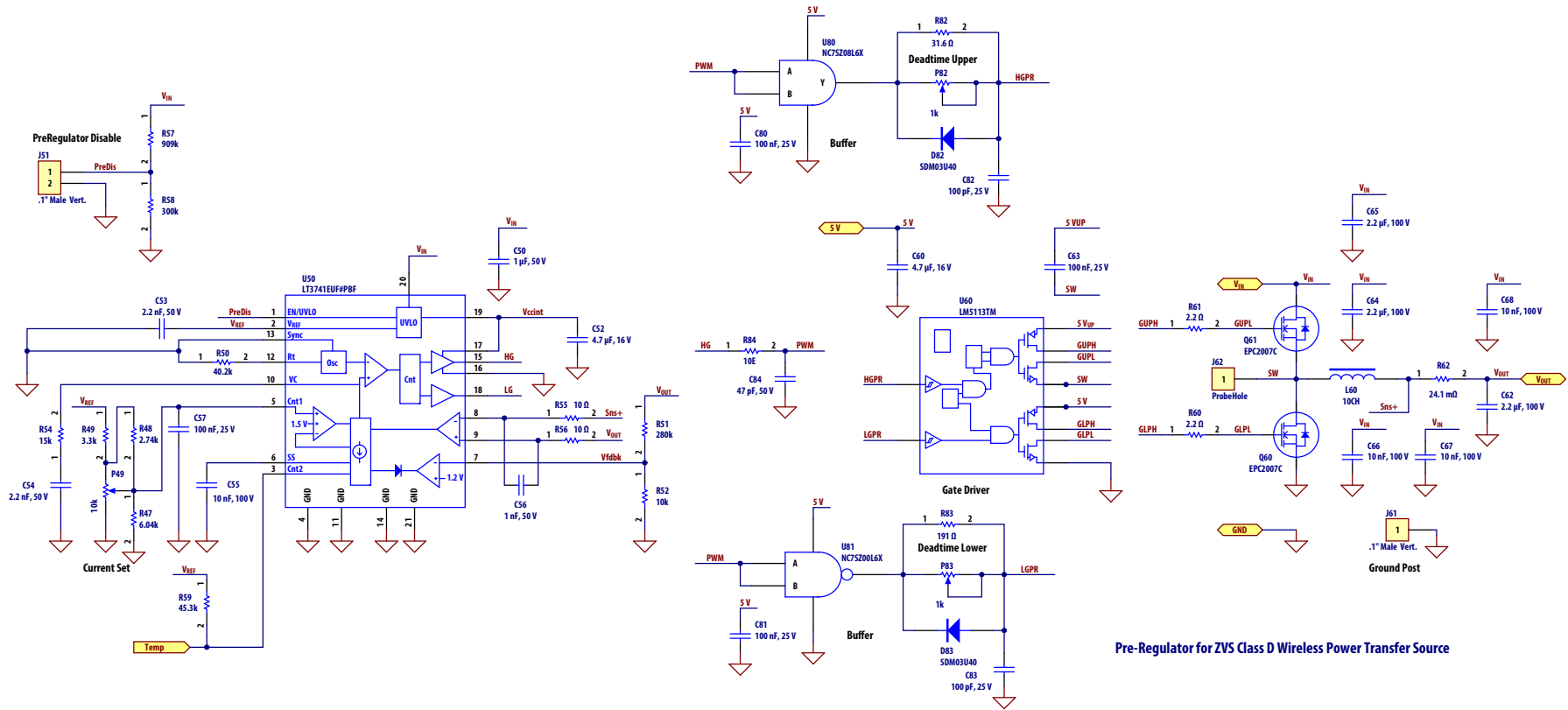

Figure 21: Pre-Regulator for ZVS Class D Wireless Power Transfer Source

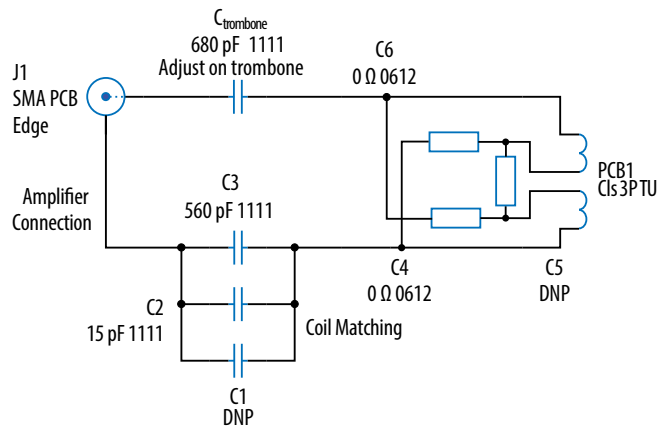

Figure 13: Class 3 Source Board

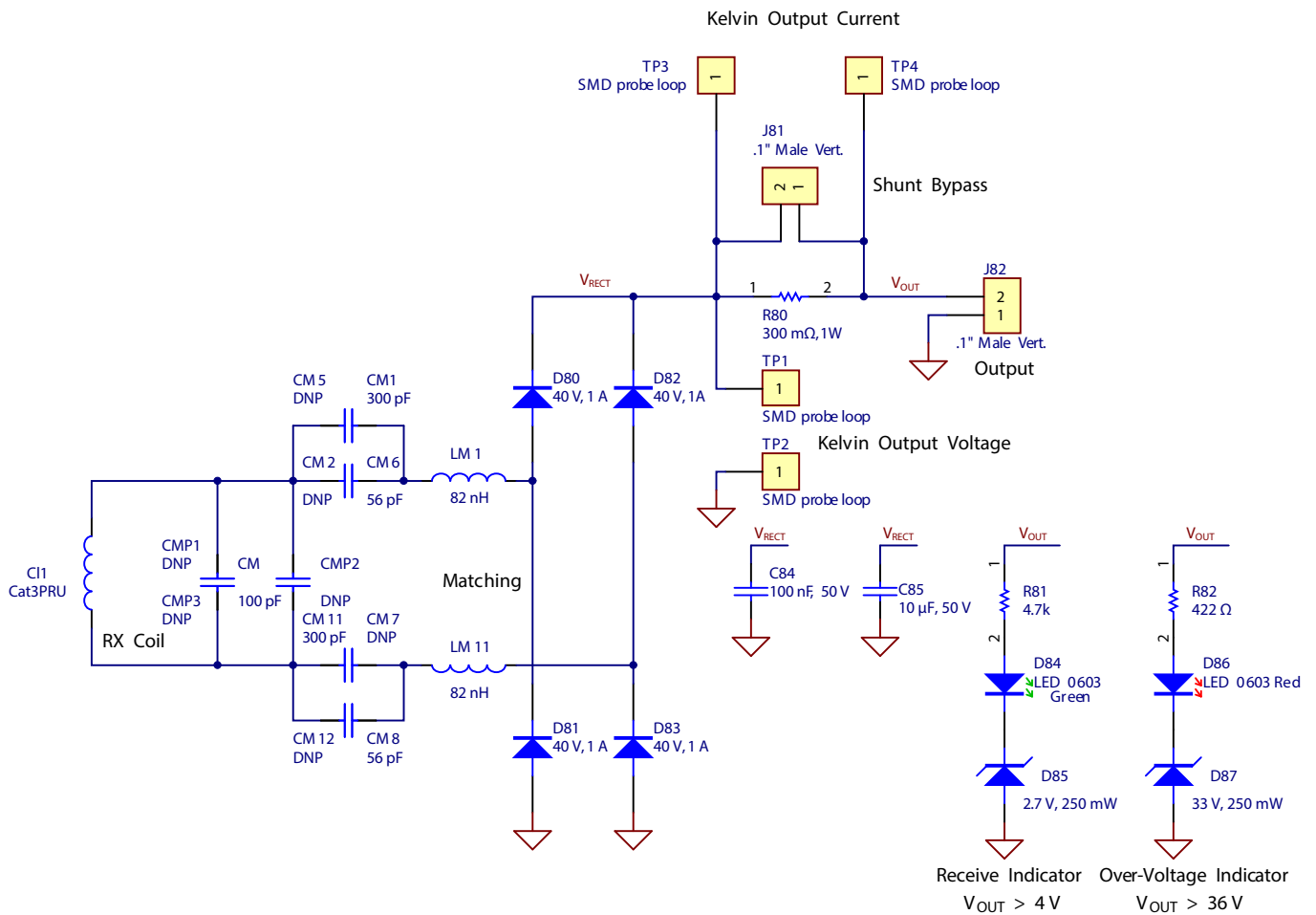

Figure 14: Category 3 Device Board

For More Information:

Please contact info@epc-co.com
or your local sales representative

Visit our website:
www.epc-co.com

Sign-up to receive
EPC updates at
bit.ly/EPCupdates
or text "EPC" to 22828



EPC Products are distributed through Digi-Key.
www.digikey.com

Demonstration Board Notification

The EPC9122 board is intended for product evaluation purposes only. It is not intended for commercial use nor is it FCC approved for resale. Replace components on the Evaluation Board only with those parts shown on the parts list (or Bill of Materials) in the Quick Start Guide. Contact an authorized EPC representative with any questions. This board is intended to be used by certified professionals, in a lab environment, following proper safety procedures. Use at your own risk.

As an evaluation tool, this board is not designed for compliance with the European Union directive on electromagnetic compatibility or any other such directives or regulations. As board builds are at times subject to product availability, it is possible that boards may contain components or assembly materials that are not RoHS compliant. Efficient Power Conversion Corporation (EPC) makes no guarantee that the purchased board is 100% RoHS compliant.

The Evaluation board (or kit) is for demonstration purposes only and neither the Board nor this Quick Start Guide constitute a sales contract or create any kind of warranty, whether express or implied, as to the applications or products involved.

Disclaimer: EPC reserves the right at any time, without notice, to make changes to any products described herein to improve reliability, function, or design. EPC does not assume any liability arising out of the application or use of any product or circuit described herein; neither does it convey any license under its patent rights, or other intellectual property whatsoever, nor the rights of others.