

QUICK START GUIDE FOR DEMONSTRATION CIRCUIT 1226A

5V 1.5A SYNCHRONOUS STEP-UP DC/DC CONVERTER

LTC3529EDCB

DESCRIPTION

Demonstration circuit 1226A is a high efficiency synchronous boost converter capable of operating with an input voltage range from 1.8V to 5.25V with a fixed 5V output. The 8 lead LTC3529 in a 2X3 mm DFN thermally enhanced package with a 1.5MHz switching frequency and 1.5A internal switches provide a very tiny overall solution for USB On-The-Go hosting applications. The LTC3529 also feature output disconnect, resetting and latching fault detection, soft-start, low quiescent current shutdown and short circuit protection.

This demonstration circuit allows the user to quickly evaluate the LTC3529 performance. Jumpers are provided for shutdown, auto restart or latching of the fault detection and selectable LED or pull up resistor for fault indication. Terminals on the board allow easy hookup to an input supply and output load.

Design files for this circuit board are available. Call the LTC factory.

LTC and Burst Mode are trademarks of Linear Technology Corporation

Table 1. Typical Specifications (25 °C)

| | | |
|-----------------------|--------------------------------|----------------|
| Input Voltage Range | | 0.5V to 5.25V |
| V_{OUT} | $V_{IN} = 1V, I_{OUT} = 100mA$ | $5V \pm 2.5\%$ |
| Output Ripple Voltage | $V_{IN} = 2V, I_{OUT} = 300mA$ | 15mV p-p |
| Efficiency | $V_{IN} = 3V, I_{OUT} = 200mA$ | 90% |

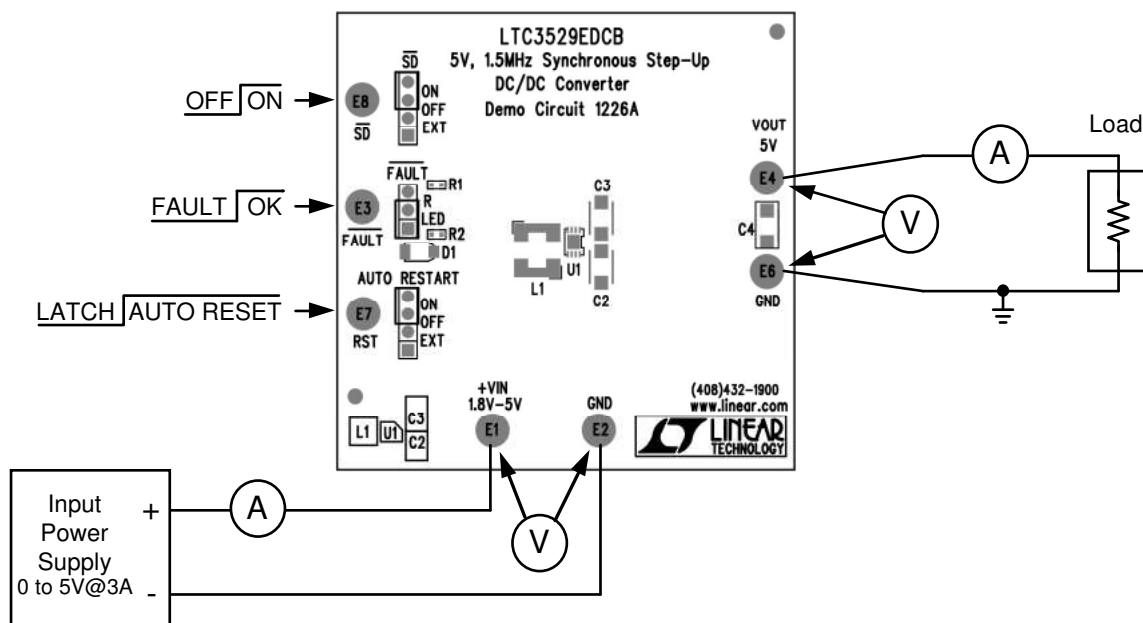

Figure 1. Demonstration Circuit Test Setup

QUICK START GUIDE FOR DEMONSTRATION CIRCUIT 1226A

5V 1.5A SYNCHRONOUS STEP-UP DC/DC CONVERTER

| Demo # | Part # | Part Marking |
|--------|-------------|--------------|
| 1226A | LTC3529EDCB | LCTZ |

Table 2. Demonstration Circuit Board Information

QUICK START PROCEDURE

Begin the evaluation by placing the top and bottom jumpers in the upper position and the middle jumper in the lower position. Connect a suitable input power supply and output load as shown in Figure 1. With a light resistive load (1k), slowly increase the input voltage. At approximately 1.6V, the output voltage will quickly rise to a regulated 5V. Verify output voltage meets specifications shown in table 1.

The input voltage can exceed the output voltage and still maintain regulation, although the maximum output current is less and efficiency is lower. It should be noted that the output voltage ripple will increase as V_{in} approaches V_{out} . The increase will occur with an input voltage between 4V and 4.8 with a ripple voltage from 30mV to 100mV pp. Increasing output capacitance will reduce this ripple voltage.

Fault Detection

The LTC3529 features output over-current circuitry that will shut down the output if an overload persists for longer than 22ms. It also will attempt a restart every 22ms until the overload is removed or it can be programmed to latch off 22ms after an overload occurs. Figure 3 shows waveforms for a 3Ω load with the AUTO RESTART jumpers set to the ON position. Moving the jumper to OFF, the output will shutdown 22ms after the overload occurred and remain shutdown until reset by either removing and reapplying input power or by moving the SD jumper to OFF then back to ON.

The FAULT jumper selects either an LED for visual indication of the FAULT output or a 1M pull-up resistor to V_{in} to interface with a microcontroller.

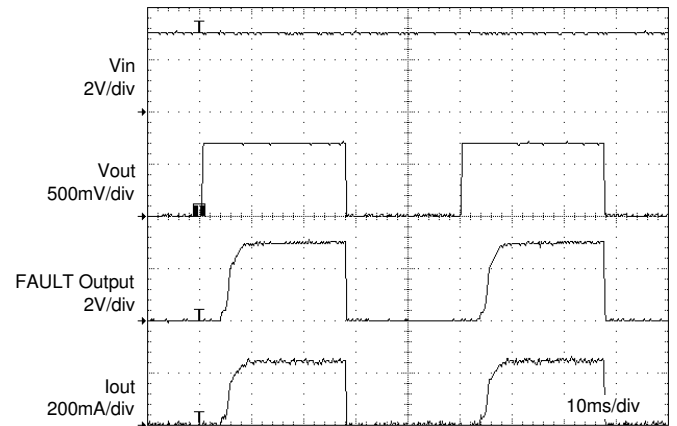

Figure 2. Auto Restart Overload Fault Detection Waveforms For a 3Ω Load.

At low input voltage, any voltage drop in the power supply wire, connections and Ammeter will result in the voltage at the input terminals dropping below the minimum voltage required for operation. A low impedance power source and wiring is necessary for maximum output current.

When verifying output ripple voltage, use the scope probe connection as shown in figure 4. Typical output voltage ripple with a 100mA and 400mA load are shown in figure 3.

Caution; Using an electronic load to evaluate this board can result in a relatively high input current surge which can produce an output voltage spike. Output voltage spikes are also possible if the input connection is subject to contact bounce.

See LTC3529 Data Sheet for additional information

QUICK START GUIDE FOR DEMONSTRATION CIRCUIT 1226A

5V 1.5A SYNCHRONOUS STEP-UP DC/DC CONVERTER

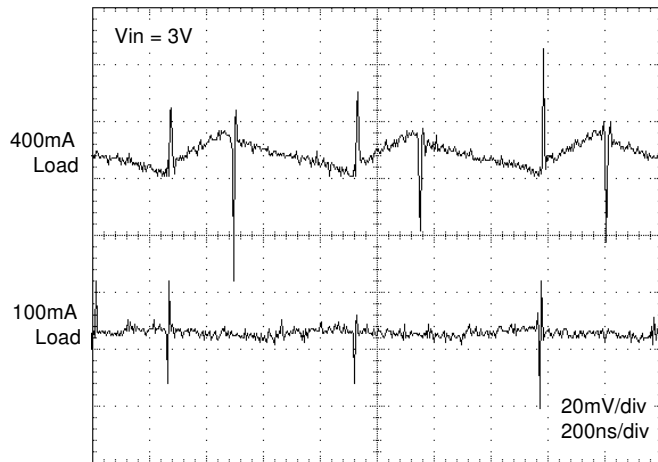

Figure 3. Typical Output Ripple Voltage

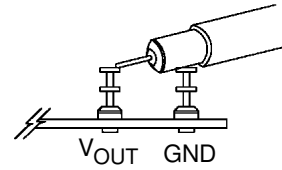
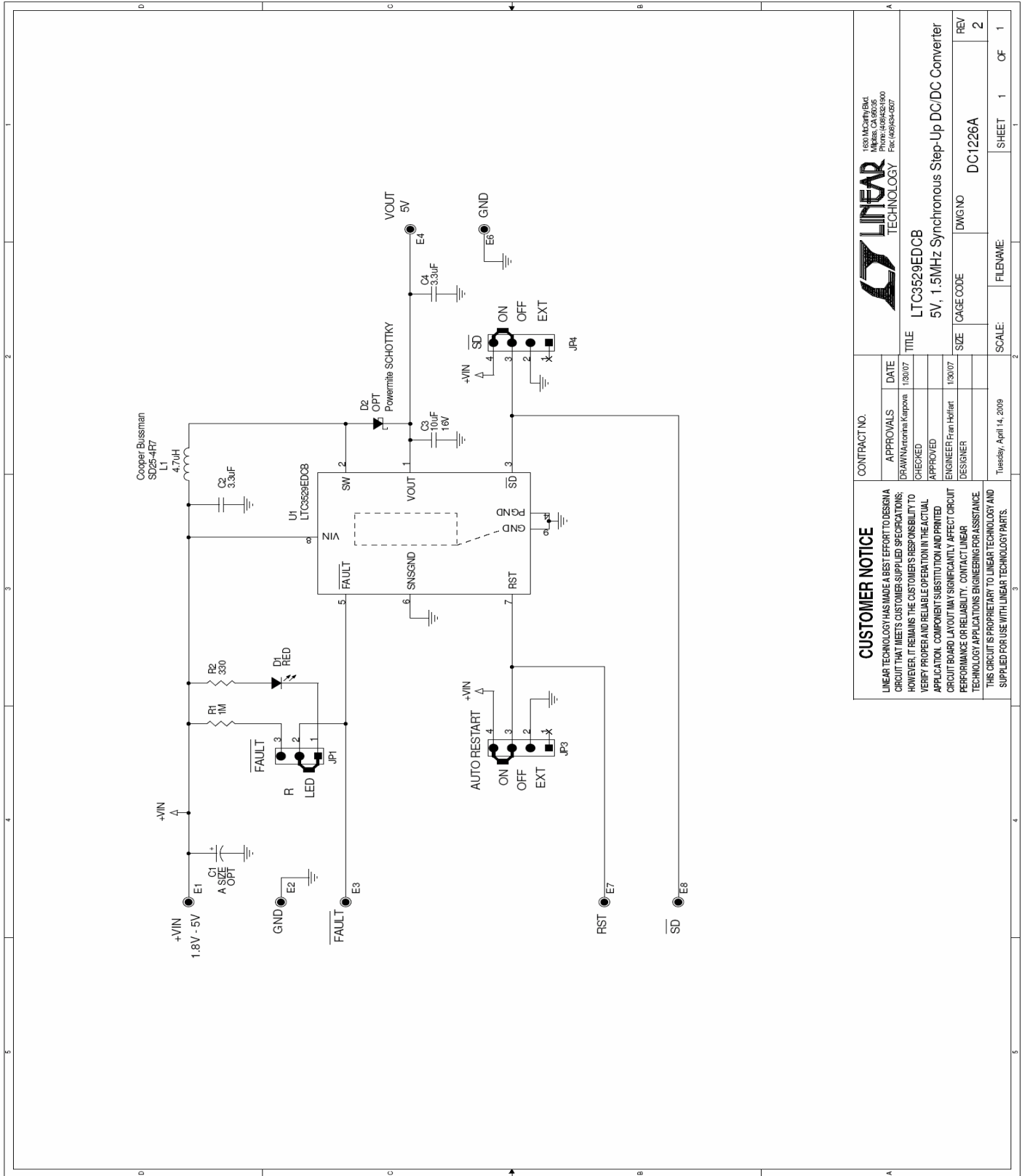

Figure 4. Scope Probe Placement for Measuring Output Ripple Voltage

QUICK START GUIDE FOR DEMONSTRATION CIRCUIT 1226A

5V 1.5A SYNCHRONOUS STEP-UP DC/DC CONVERTER



| | | | | |
|-------------------------------------------------------------------------------------------------------------------------------------------------------------------------------------------------------------------------------------------------------------------------------------------------------------------------------------------------------------------------|--|-------------------------|-----------|---------|
| CUSTOMER NOTICE | | CONTRACT NO. | APPROVALS | DATE |
| LINEAR TECHNOLOGY HAS MADE A BEST EFFORT TO DESIGN A CIRCUIT THAT MEETS CUSTOMER-SUPPLIED SPECIFICATIONS; HOWEVER, IT REMAINS THE CUSTOMER'S RESPONSIBILITY TO VERIFY PROPER AND RELIABLE OPERATION IN THE ACTUAL APPLICATION. COMPONENT SUBSTITUTION MAY AFFECT CIRCUIT PERFORMANCE OR RELIABILITY. CONTACT LINEAR TECHNOLOGY APPLICATIONS ENGINEERING FOR ASSISTANCE. | | | CHECKED | 1/30/07 |
| THIS CIRCUIT IS PROPRIETARY TO LINEAR TECHNOLOGY AND SUPPLIED FOR USE WITH LINEAR TECHNOLOGY PARTS. | | | APPROVED | |
| | | | DESIGNER | 1/30/07 |
| | | Tuesday, April 14, 2009 | | |

| | | | |
|------------------------------------------------|-----------|------------------------------------------------------------------------------------|--------------|
| LINEAR TECHNOLOGY | | 1350 McCarty Rd. Milpitas, CA 95035 Phone: 408.943.2100 Fax: 408.943.2077 | |
| TITLE: LTC3529EDCB | | | |
| 5V, 1.5MHz Synchronous Step-Up DC/DC Converter | | | |
| REV | SIZE | DWG NO | REV |
| 2 | CAGE CODE | DC1226A | 2 |
| SCALE: | | FILENAME: | SHEET 1 OF 1 |