

1 W Wireless power transmitter based on STM32F0

Data brief

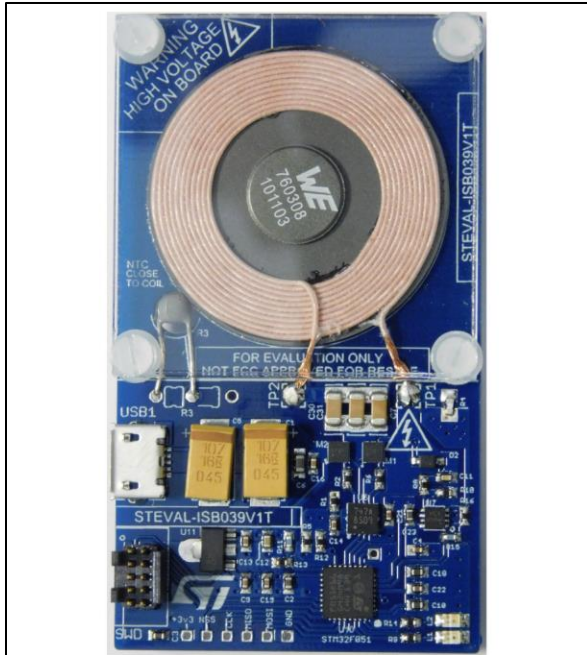

Description

The STEVAL-ISB039V1T is a wireless power transmitter based on the STM32F0 microcontroller and primarily designed for small systems requiring easy recharging up to 1 W; this solution can be adjusted up to 2.5 W.

The wireless power transmitter consists of a power conversion unit which generates the alternating electromagnetic field transmitted between two planar coils.

The built-in USB connector supplies the wireless power transmitter and the SWD debugger connector allows the monitoring of system parameters such as battery charging level, power transmitted, efficiency, working frequency and power receiver identification.

The firmware is a single STM32CubeMX platform-independent library providing a simple and easy to customize solution for the design of wireless power transmitters with proprietary features.

Features

- Core: ARM® 32-bit Cortex® -M0 with 32 Kbytes Flash, 48 MHz CPU
- 1 W output power
- WPC 1.1 based communication protocol
- High efficiency N-channel Half Bridge architecture with adaptive dead-time control
- Synchronous digital demodulation of power carrier, significantly reduces the BOM
- Standard or enhanced power transmitter coil
- Coil temperature monitoring through NTC
- MCU firmware available open for customization
- Built-in USB connector for input supply voltage
- RoHS compliant

1 Schematic diagrams

Figure 1: STEVAL-ISB039V1T circuit schematic (1 of 3)

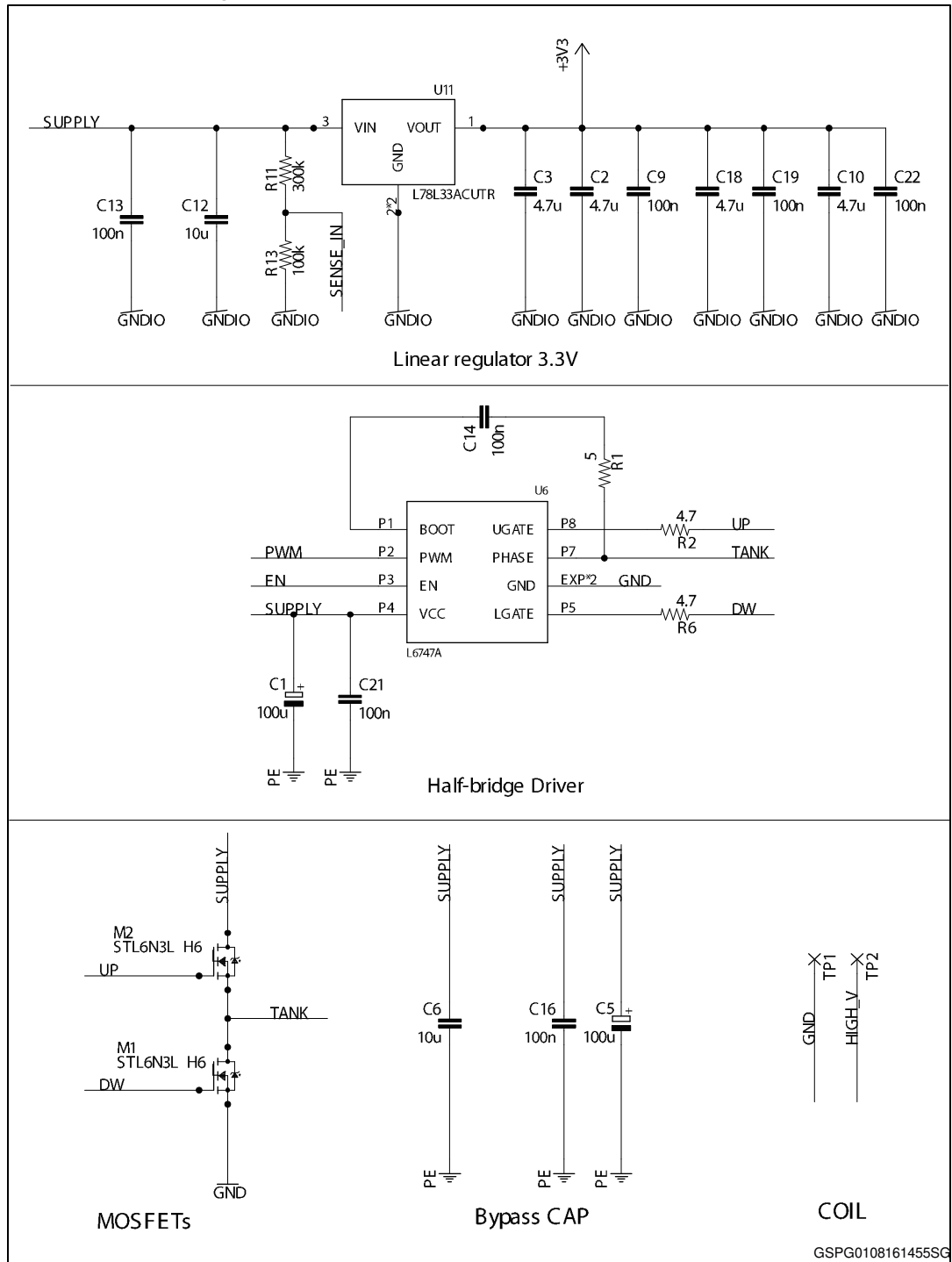
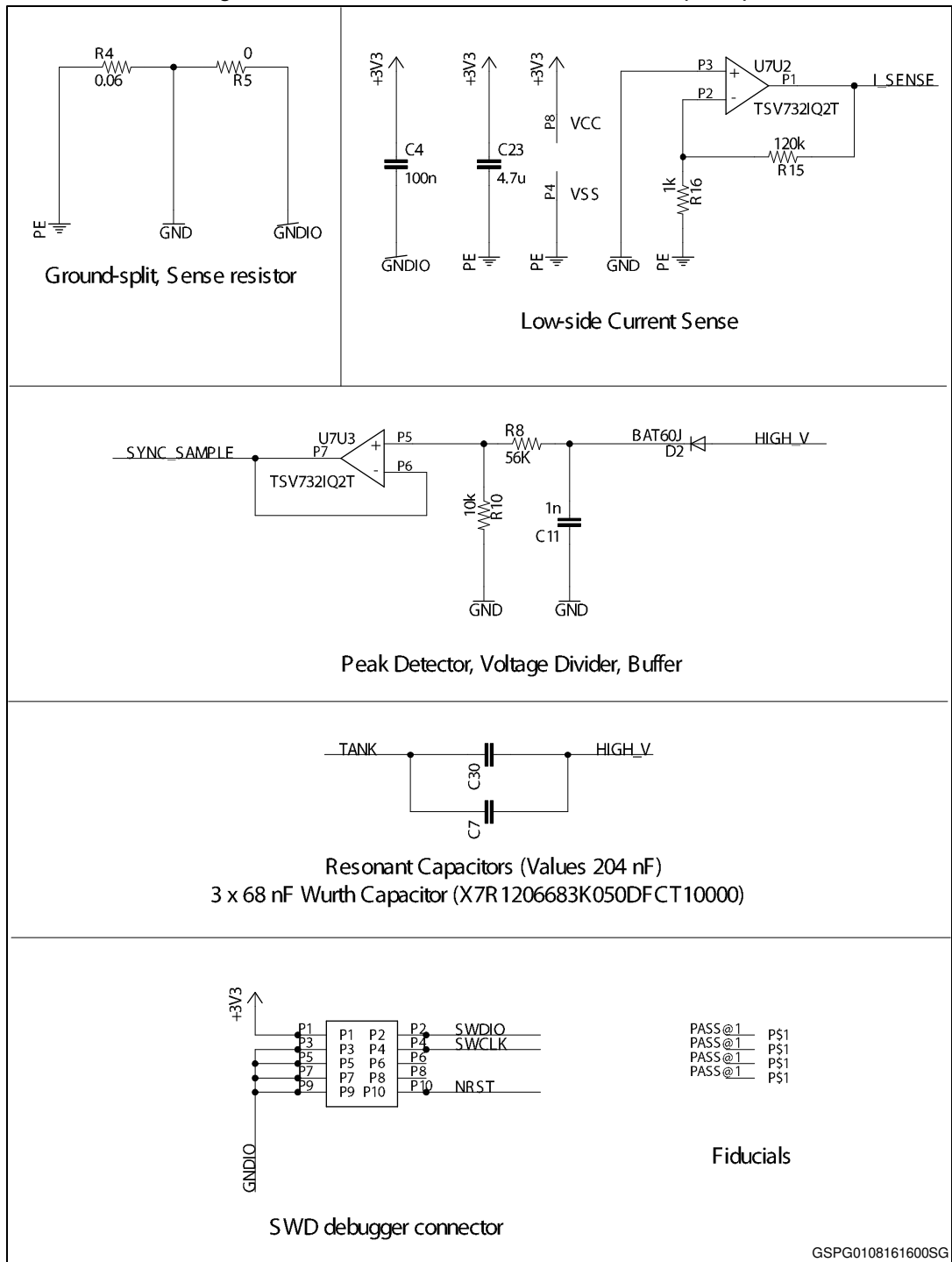
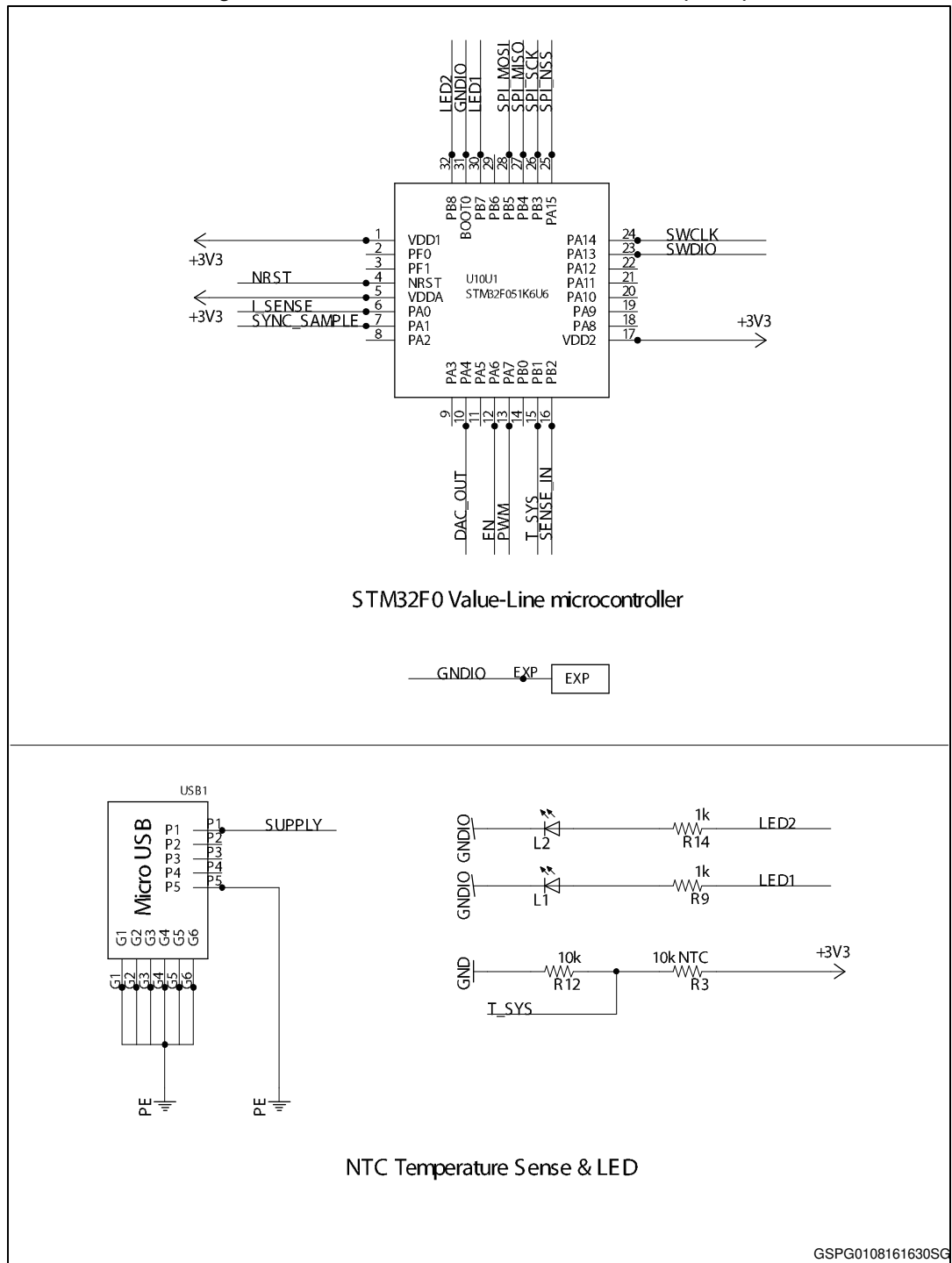

Figure 2: STEVAL-ISB039V1T circuit schematic (2 of 3)



GSPG0108161600SG

Figure 3: STEVAL-ISB039V1T circuit schematic (3 of 3)



2 Revision history

Table 1: Document revision history

Date	Version	Changes
05-Aug-2016	1	Initial release.

IMPORTANT NOTICE - PLEASE READ CAREFULLY

STMicroelectronics NV and its subsidiaries ("ST") reserve the right to make changes, corrections, enhancements, modifications, and improvements to ST products and/or to this document at any time without notice. Purchasers should obtain the latest relevant information on ST products before placing orders. ST products are sold pursuant to ST's terms and conditions of sale in place at the time of order acknowledgement.

Purchasers are solely responsible for the choice, selection, and use of ST products and ST assumes no liability for application assistance or the design of Purchasers' products.

No license, express or implied, to any intellectual property right is granted by ST herein.

Resale of ST products with provisions different from the information set forth herein shall void any warranty granted by ST for such product.

ST and the ST logo are trademarks of ST. All other product or service names are the property of their respective owners.

Information in this document supersedes and replaces information previously supplied in any prior versions of this document.

© 2016 STMicroelectronics – All rights reserved