

THIS DRAWING IS UNPUBLISHED. RELEASED FOR PUBLICATION 20
 © COPYRIGHT 20 BY - ALL RIGHTS RESERVED.

| REVISIONS | | | | | |
|-----------|-----|---------------------------|-----------|-----|------|
| P | LTR | DESCRIPTION | DATE | DWN | APVD |
| A | | RELEASE | 31OCT2016 | JY | SH |
| B | | REVISED PER ECO-17-009888 | 07JUL2017 | JY | SH |
| C | | REVISED PER ECO-18-012273 | 10JUL2018 | JY | SH |

2-2170747-2 AS SHOWN

1. COMPONENTS
 CAGE ASSEMBLY: NICKEL-SILVER ALLOY
 HEAT SINK: ALUMINUM/BLACK ANODIZE
 HEAT SINK CLIP: STAINLESS STEEL
 EMI SPRING: COPPER ALLOY/NICKEL PLATE
 LIGHT PIPE: CLEAR POLYCARBONATE
 ORGANIZER: POLYESTER WITH UL 94 V-0
2. REFERENCE APPLICATION SPECIFICATION 114-23023 FOR RECOMMENDED DRILL HOLE DIAMETER AND PLATING THICKNESS
3. DATUM AND BASIC DIMENSION ESTABLISHED BY CUSTOMER
4. DIMENSION OF HEAT SINK APPLIES WITH MODULE INSERTED IN CAGE.
5. HEAT SINKS, HEAT SINK CLIPS AND LIGHT PIPES ARE SHIPPED ASSEMBLED ON CAGE
6. MINIMUM PC BOARD THICKNESS: SINGLE SIDED: 1.57 MIN
 DOUBLE SIDED: 2.20 MIN
7. DATUM **-A-** IS TOP SURFACE OF THE HOST BOARD.
8. THESE HOLES ARE OPTIONAL WHEN THE REAR PINS ARE REMOVED.
9. MATES WITH QSFP28 MSA COMPATIBLE TRANSCEIVER.
10. DATE CODE (YYWWD) MARKED APPROXIMATELY AS SHOWN.
11. NOTED DIMENSIONS ONLY APPLY TO CAGE ASSEMBLY WITH LIGHT PIPE.
12. THE CUSTOMIZED HEAT SINK HAVE NO SURFACE FINISH ONLY FOR 2170747-7/-8/-9.
13. CAGE ASSEMBLY WITH HS AND LIGHT PIPE ARE UNASSEMBLED, AND PACKAGED INDIVIDUALLY IN TRAYS. ONLY APPLICABLE TO 2170747-7.

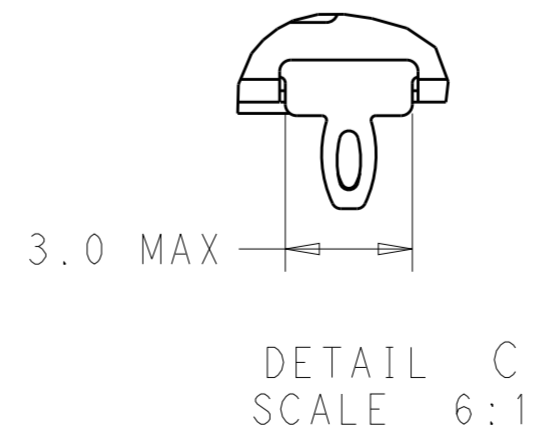
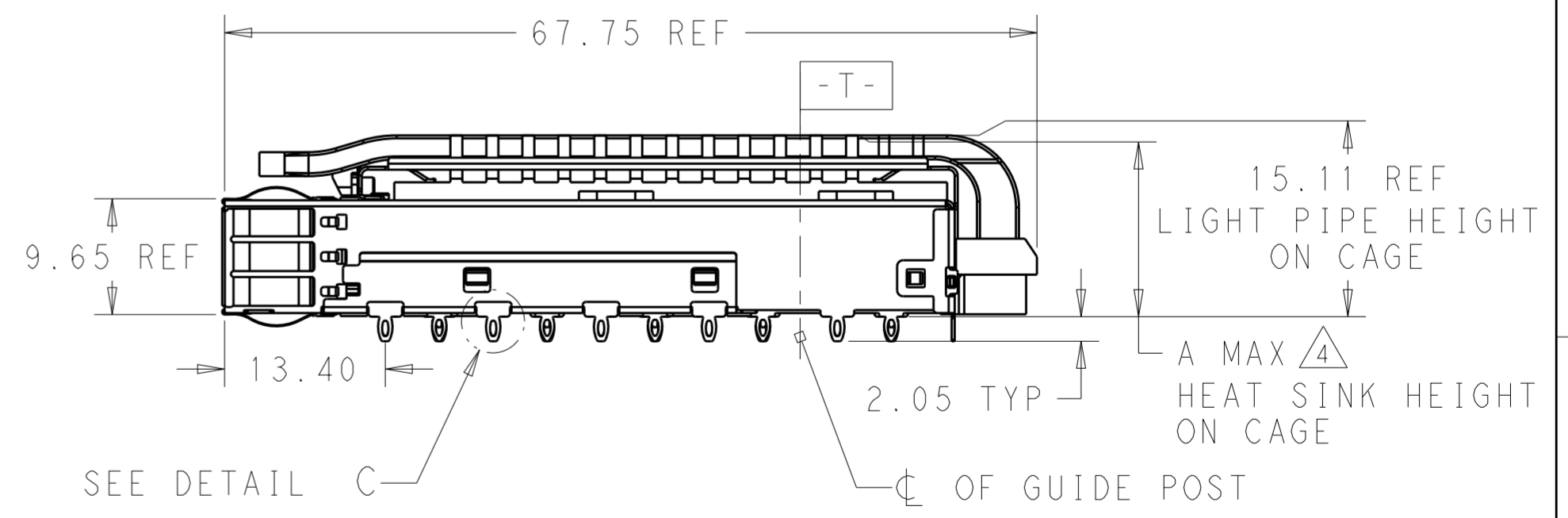
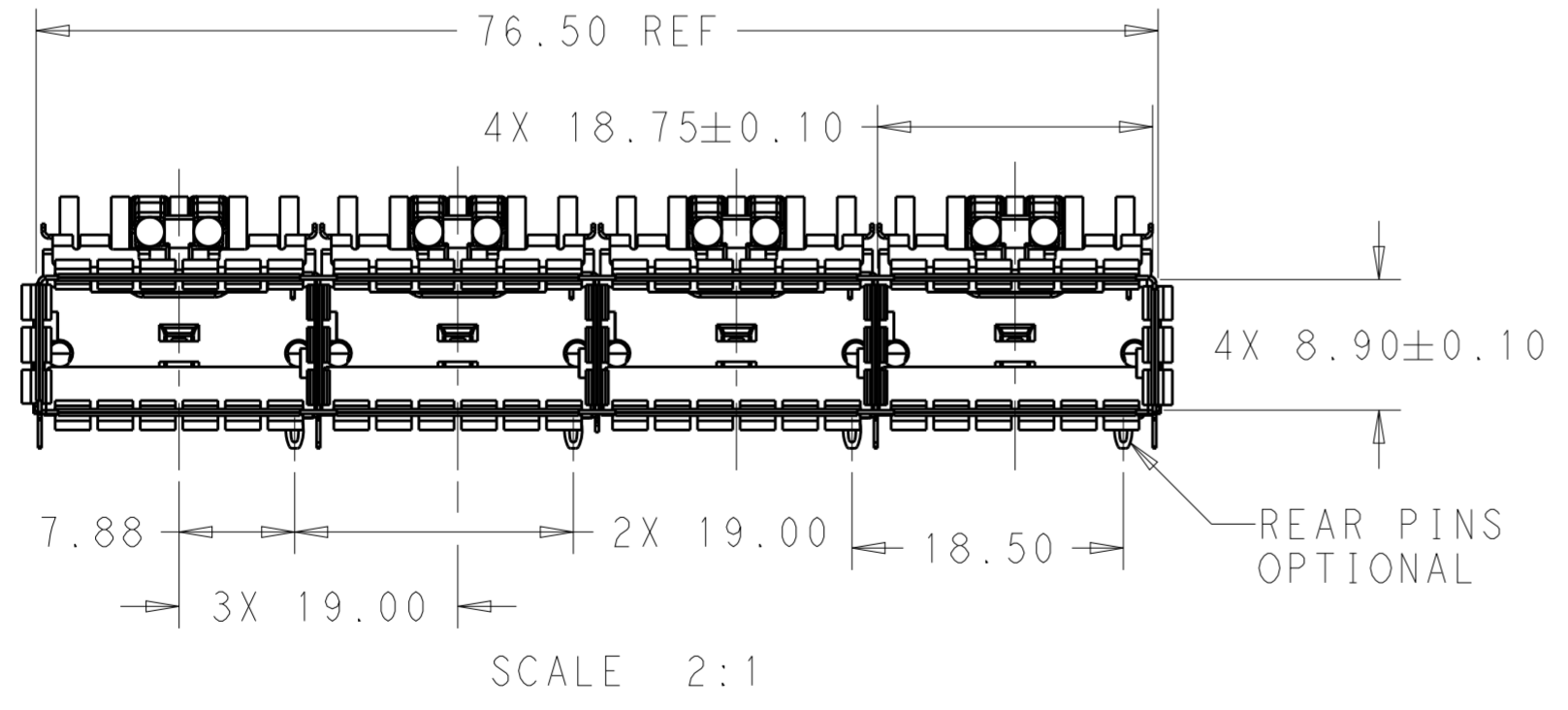
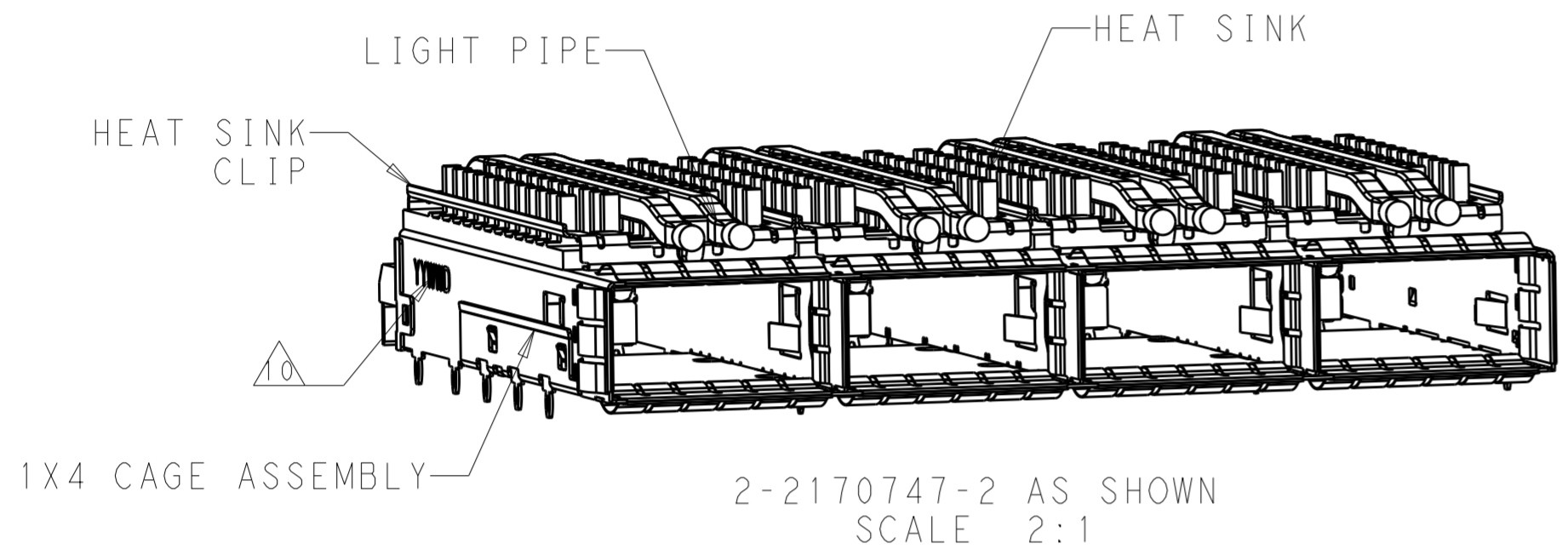

| | | | | |
|--|--|--------------------------------|---|---------------|
| THIS DRAWING IS A CONTROLLED DOCUMENT. | | DWN JASON YANG 04JUN2014 | TE Connectivity | |
| | | CHK SEAN HAN 07JUN2014 | | |
| DIMENSIONS: | TOLERANCES UNLESS OTHERWISE SPECIFIED: | APVD | NAME | |
| mm | 0 PLC ± 1 PLC ±0.25 2 PLC ±0.2 3 PLC ± 4 PLC ± | PRODUCT SPEC | RECEPTACLE CAGE ASSEMBLY WITH HEAT SINKS AND LIGHT PIPES, THRU BEZEL, 1X4, QSFP28, SPRING | |
| | ANGLES ± FINISH | APPLICATION SPEC | SIZE | CAGE CODE |
| MATERIAL | SEE NOTES | 114-32023 | A200779 | DRAWING NO |
| SEE NOTES | SEE NOTES | WEIGHT | C-2170747 | |
| | | CUSTOMER DRAWING | SCALE 1:1 | SHEET 1 OF 13 |

THIS DRAWING IS UNPUBLISHED. RELEASED FOR PUBLICATION 20
 © COPYRIGHT 20 BY - ALL RIGHTS RESERVED.

| REVISIONS | | | | | |
|-----------|-----|-------------|------|-----|------|
| P | LTR | DESCRIPTION | DATE | DWN | APVD |
| - | | SEE SHEET 1 | - | - | - |
| | | | | | |
| | | | | | |

HEAT SINK OPTION

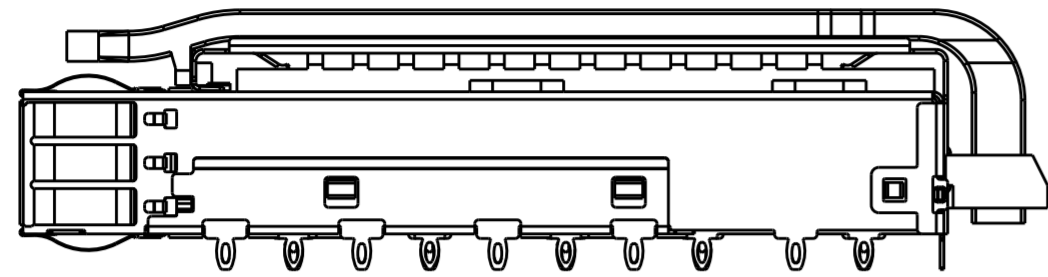

PCI HEAT SINK
SCALE 2:1

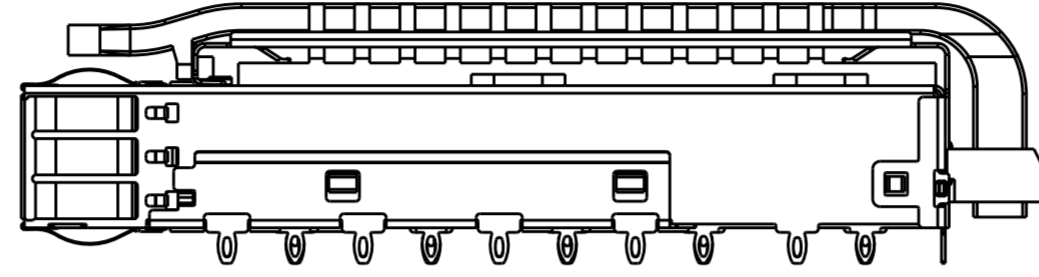

SAN HEAT SINK
SCALE 2:1

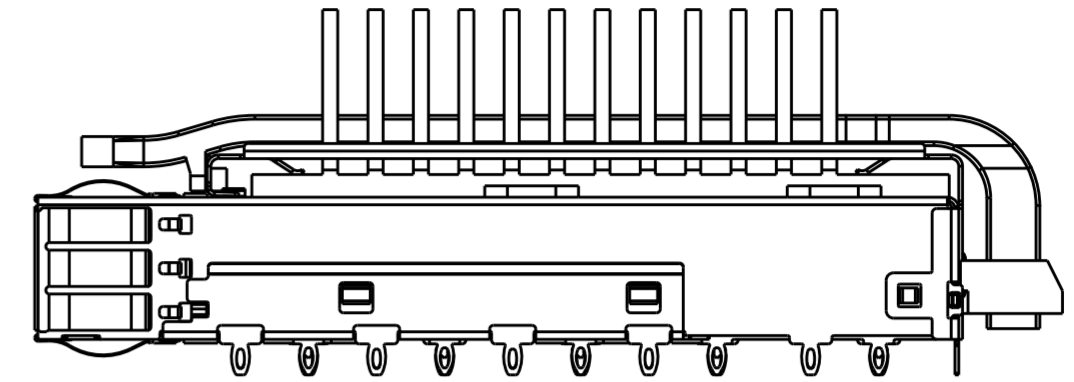

NETWORKING HEAT SINK
SCALE 2:1

LIGHT PIPE OPTION

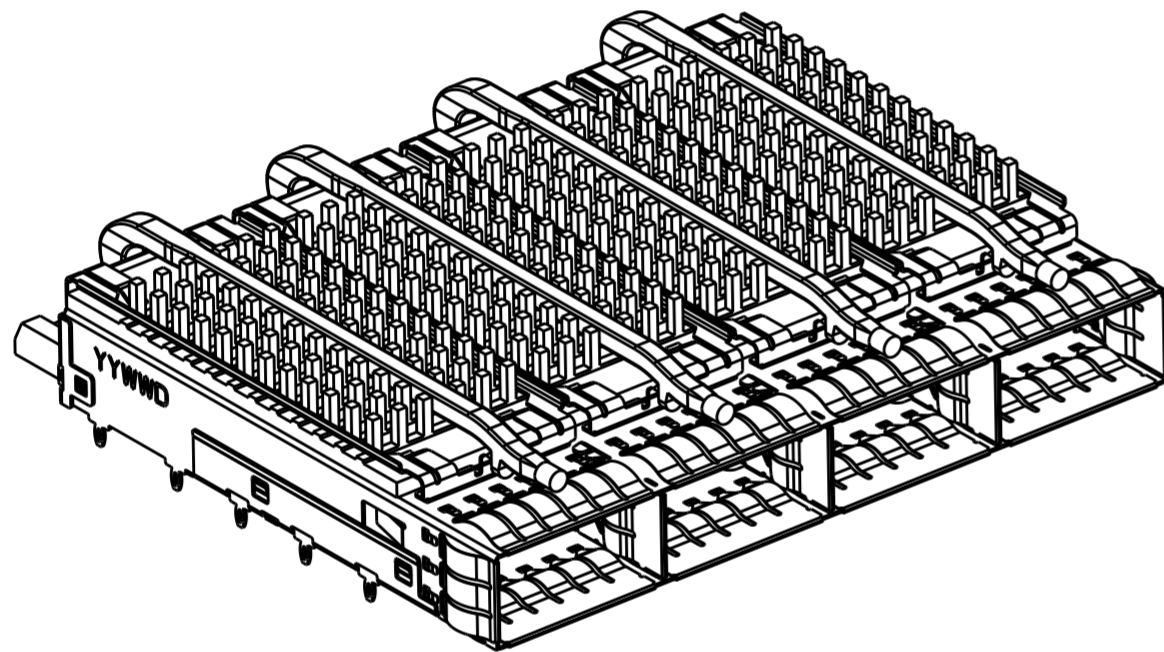

SINGLE LIGHT PIPE
SCALE 3:2

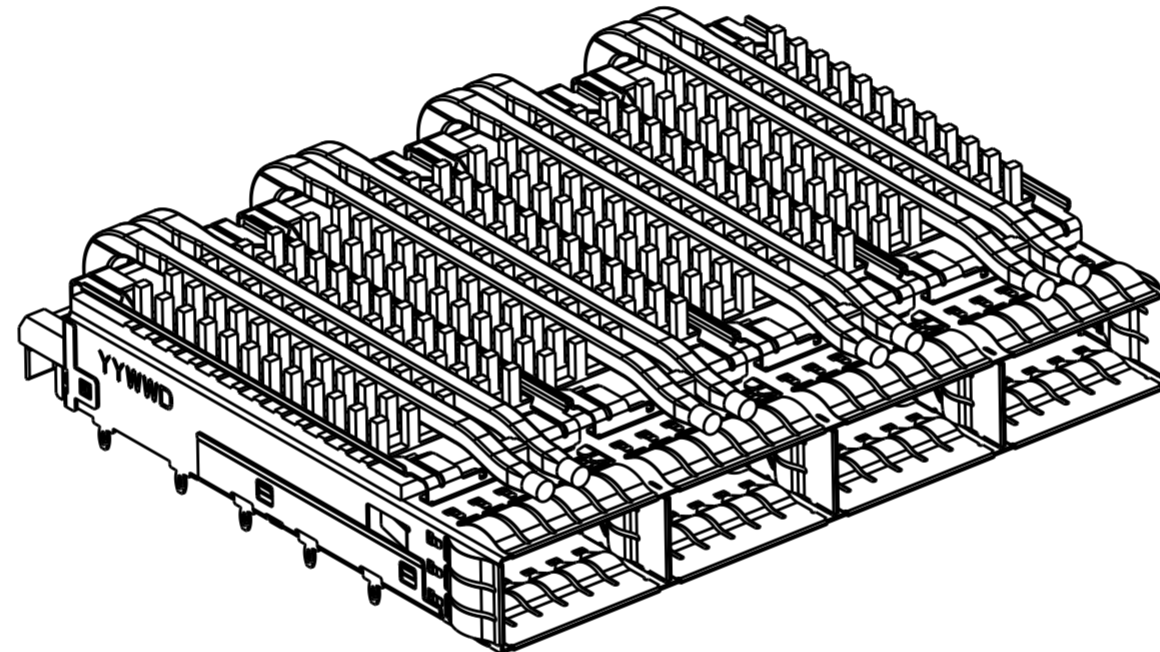

DUAL LIGHT PIPE
SCALE 3:2

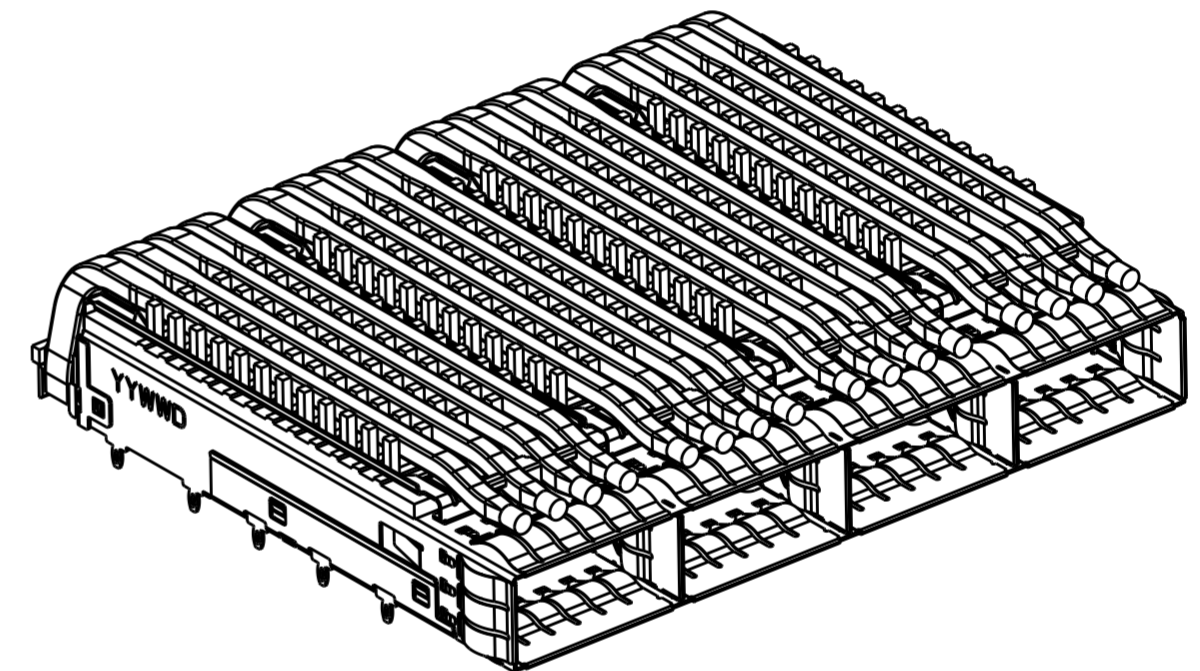

QUAD LIGHT PIPE
SCALE 3:2

OF REAR PIN OPTION

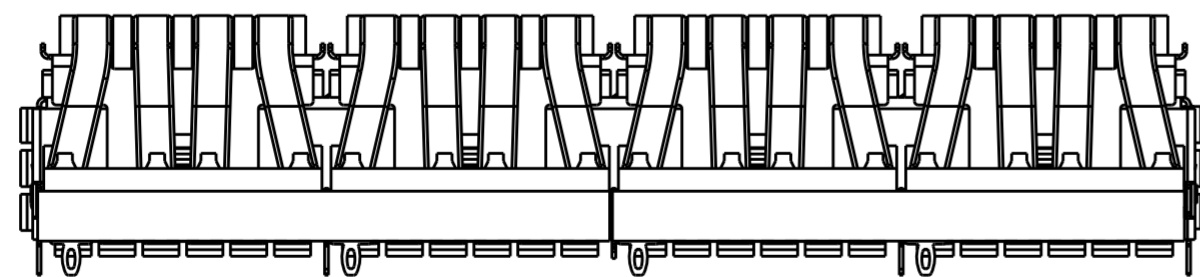

1 REAR PIN
SCALE 2:1

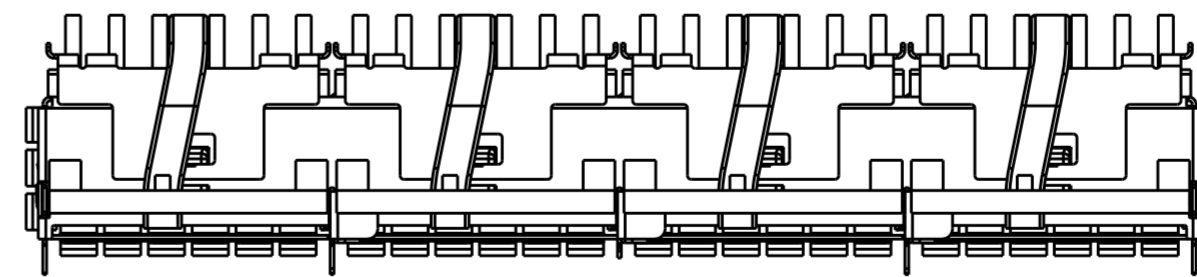

0 REAR PIN
SCALE 2:1

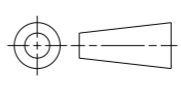
| | | | | | |
|--|--|--|---|---|---------------|
| THIS DRAWING IS A CONTROLLED DOCUMENT. | | DWN JASON YANG 04JUN2014 |  TE Connectivity | | |
| | | CHK SEAN HAN 07JUN2014 | | | |
| DIMENSIONS: mm  | | TOLERANCES UNLESS OTHERWISE SPECIFIED: 0 PLC ± 1 PLC ±0.25 2 PLC ±0.2 3 PLC ± 4 PLC ± ANGLES ± FINISH ± | | NAME RECEPTACLE CAGE ASSEMBLY WITH HEAT SINKS AND LIGHT PIPES, THRU BEZEL, 1X4, QSFP28, SPRING | |
| MATERIAL SEE NOTES | | PRODUCT SPEC 108-19428 APPLICATION SPEC 114-32023 WEIGHT - | | SIZE CAGE CODE DRAWING NO A200779 C-2170747 | |
| | | CUSTOMER DRAWING | | SCALE 1:1 | SHEET 2 OF 13 |

THIS DRAWING IS UNPUBLISHED. RELEASED FOR PUBLICATION 20
 © COPYRIGHT 20 BY - ALL RIGHTS RESERVED.

| REVISIONS | | | | |
|-----------|-----|-------------|------|------|
| P | LTR | DESCRIPTION | DATE | APVD |
| - | - | SEE SHEET 1 | - | - |
| | | | | |
| | | | | |

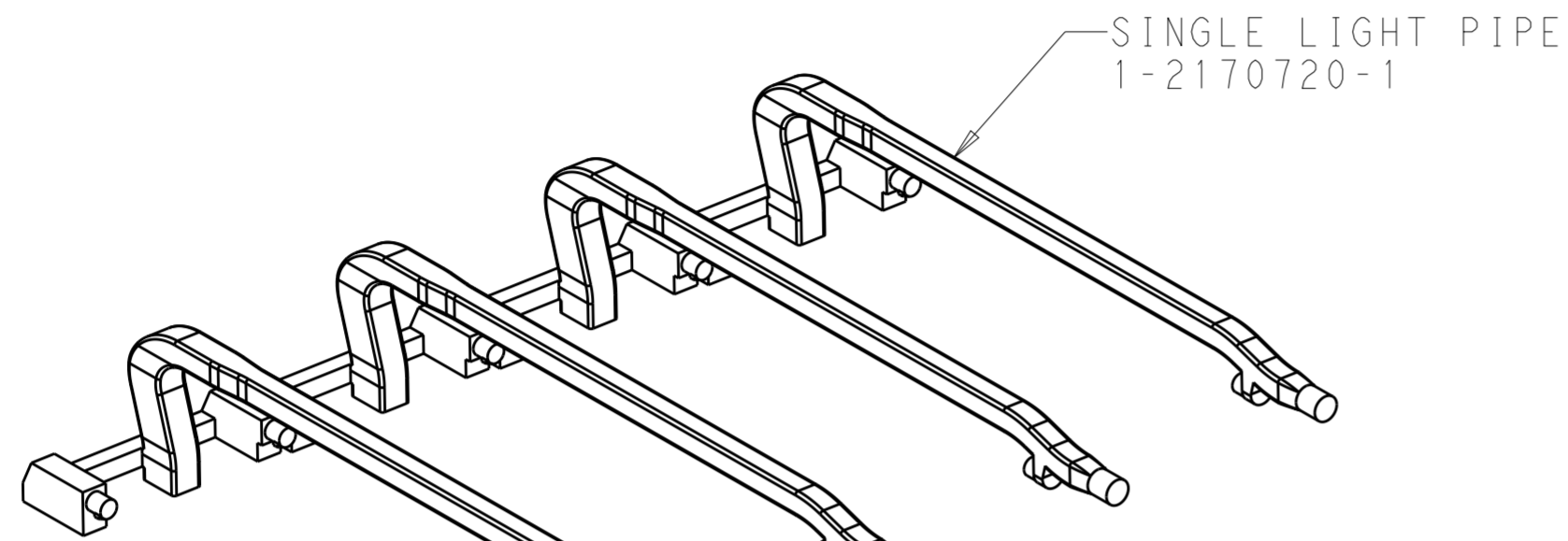

CAGE ASSEMBLY WITH HS
2170745-7

2170747-7 UNASSEMBLED ¹³
 CAGE ASSY WITH HS AND LIGHT PIPE ARE UNASSEMBLED,
 AND PACKAGED INDIVIDUALLY.
 CUSTOMIZED HEAT SINK
 SCALE 2:1

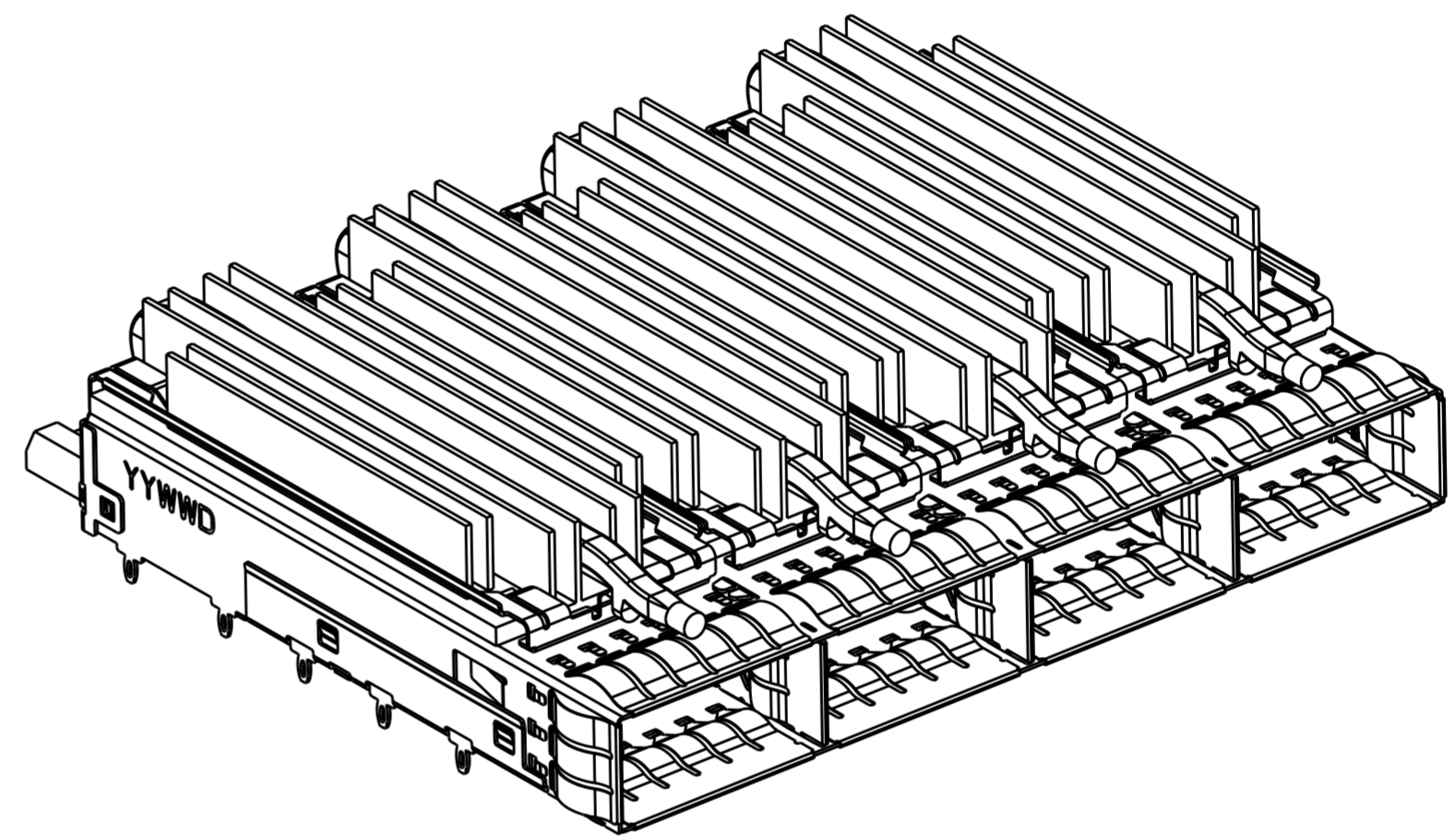

2170747-8 ASSEMBLED
 ASSEMBLED AND PAKCAGED TOGETHER, CUSTOMIZED HEAT SINK
 SCALE 2:1

| | | | | |
|--|--|--------------------------------|---|--------------------|
| THIS DRAWING IS A CONTROLLED DOCUMENT. | | DWN JASON YANG 04JUN2014 | STE TE Connectivity | |
| | | CHK SEAN HAN 07JUN2014 | | |
| DIMENSIONS: mm | TOLERANCES UNLESS OTHERWISE SPECIFIED: | APVD - | NAME RECEPTACLE CAGE ASSEMBLY WITH HEAT SINKS AND LIGHT PIPES, THRU BEZEL, 1X4, QSFP28, SPRING | |
| | 0 PLC ± 1 PLC ±0.25 2 PLC ±0.2 3 PLC ± 4 PLC ± ANGLES ± FINISH | PRODUCT SPEC 108-19428 | SIZE 114-32023 | RESTRICTED TO - |
| MATERIAL SEE NOTES | SEE NOTES | WEIGHT - | SCALE 1:1 | SHEET 3 OF 13 |
| | | CUSTOMER DRAWING | DRAWING NO A200779 C-2170747 | REV C |

THIS DRAWING IS UNPUBLISHED. RELEASED FOR PUBLICATION 20
 © COPYRIGHT 20 BY - ALL RIGHTS RESERVED.

| REVISIONS | | | | |
|-----------|-----|-------------|------|------|
| P | LTR | DESCRIPTION | DATE | APVD |
| - | | SEE SHEET 1 | - | - |
| | | | | |
| | | | | |

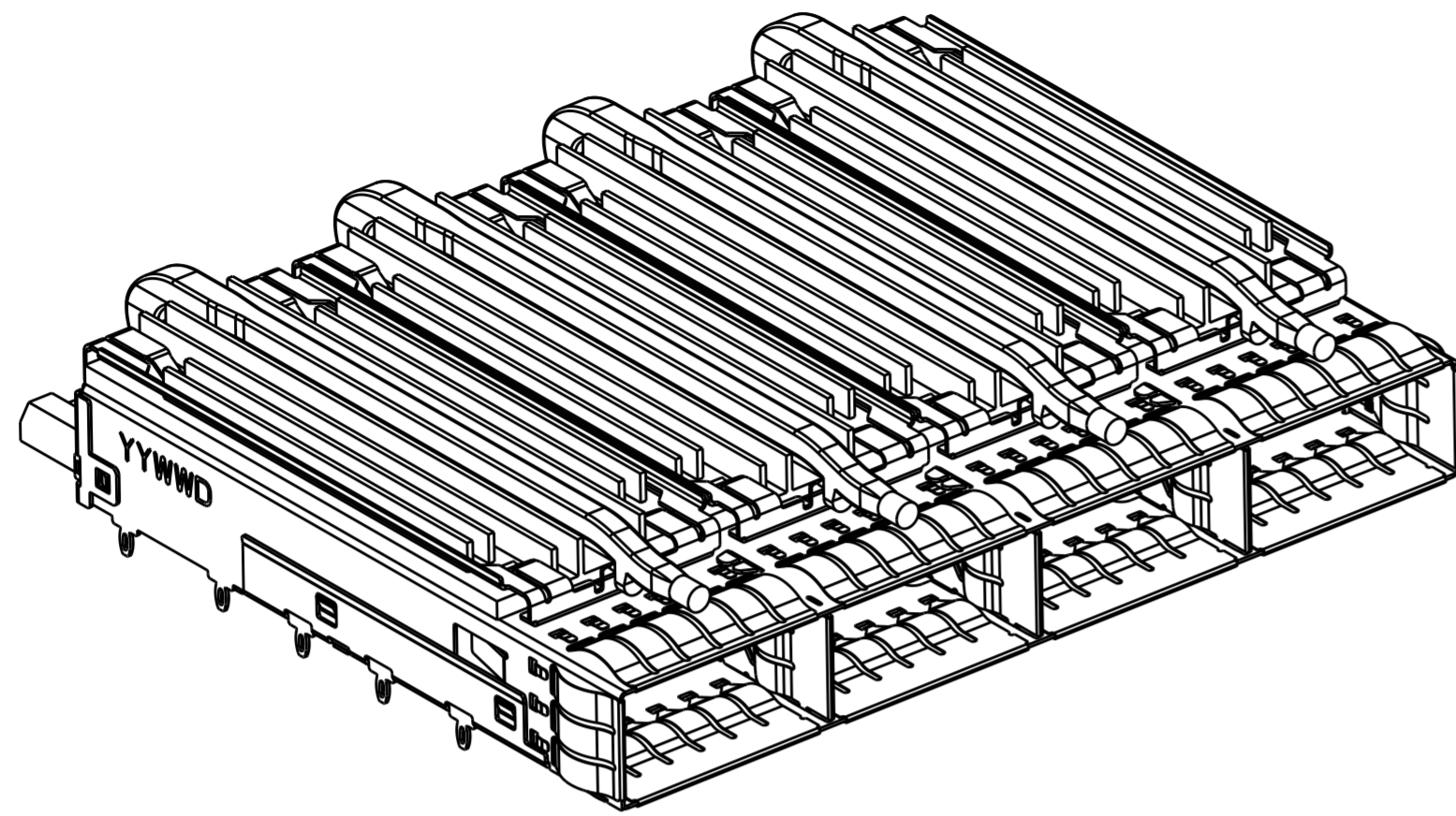

2170747-9 AS SHOWN
 WITH CUSTOMIZED HEAT SINK
 SCALE 2:1

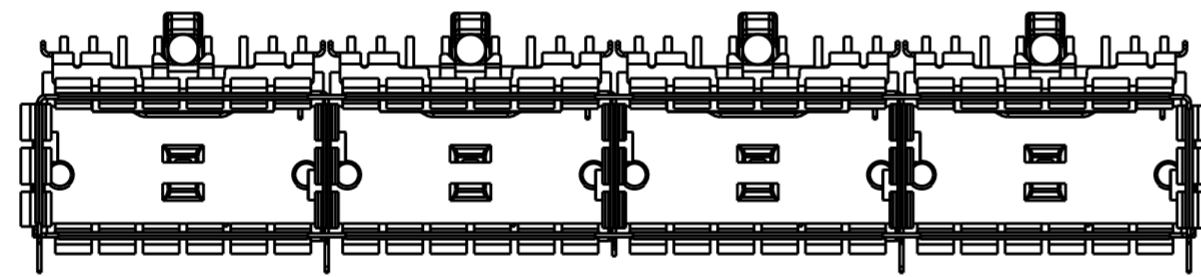

SCALE 2:1

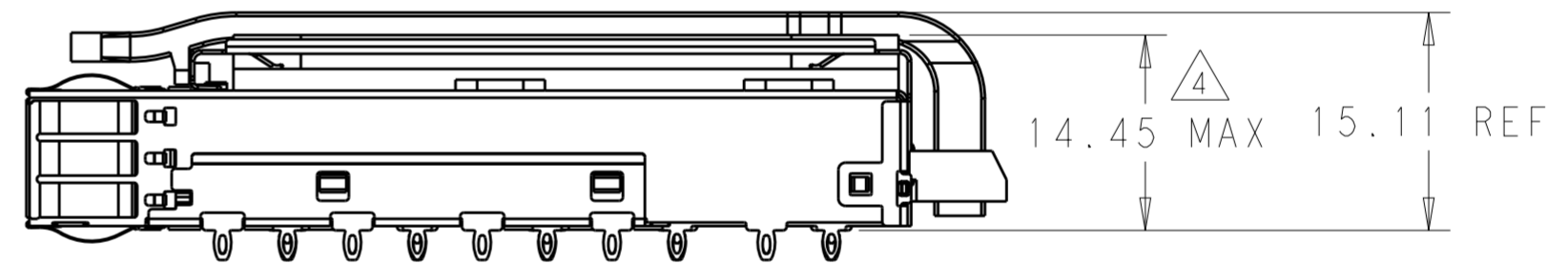

| | | | | |
|--|--|----------------------------------|---|---|
| THIS DRAWING IS A CONTROLLED DOCUMENT. | | DWN JASON YANG 04 JUN 2014 |  TE Connectivity | |
| | | CHK SEAN HAN 07 JUN 2014 | | |
| DIMENSIONS: | TOLERANCES UNLESS OTHERWISE SPECIFIED: | APVD | NAME | RECEPTACLE CAGE ASSEMBLY WITH HEAT SINKS AND LIGHT PIPES, THRU BEZEL, 1X4, QSFP28, SPRING |
| mm | 0 PLC ± 1 PLC ±0.25 2 PLC ±0.2 3 PLC ± 4 PLC ± ANGLES ± FINISH | PRODUCT SPEC 108-19428 | SIZE | |
| MATERIAL | SEE NOTES | APPLICATION SPEC 114-32023 | CAGE CODE | DRAWING NO |
| | | WEIGHT | A200779 | C-2170747 |
| | | CUSTOMER DRAWING | SCALE | SHEET |
| | | | 1:1 | 4 OF 13 |
| | | | | REV C |

THIS DRAWING IS UNPUBLISHED. RELEASED FOR PUBLICATION 20
 © COPYRIGHT 20 BY - ALL RIGHTS RESERVED.

| REVISIONS | | | | |
|-----------|-----|-------------|------|------|
| P | LTR | DESCRIPTION | DATE | APVD |
| - | | SEE SHEET 1 | - | - |
| | | | | |
| | | | | |

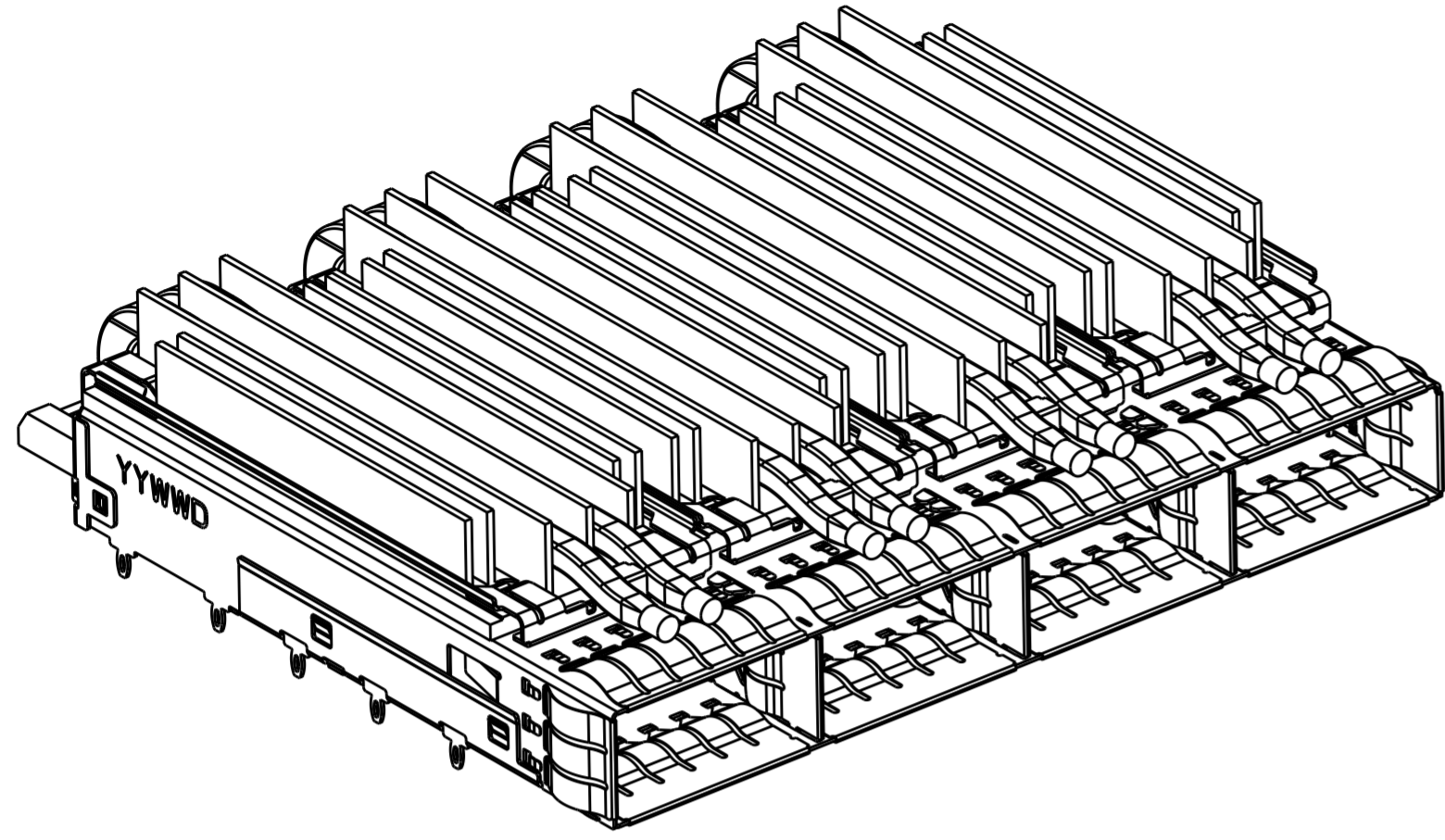

2-2170747-7 AS SHOWN
 WITH CUSTOMIZED HEAT SINK
 SCALE 2:1

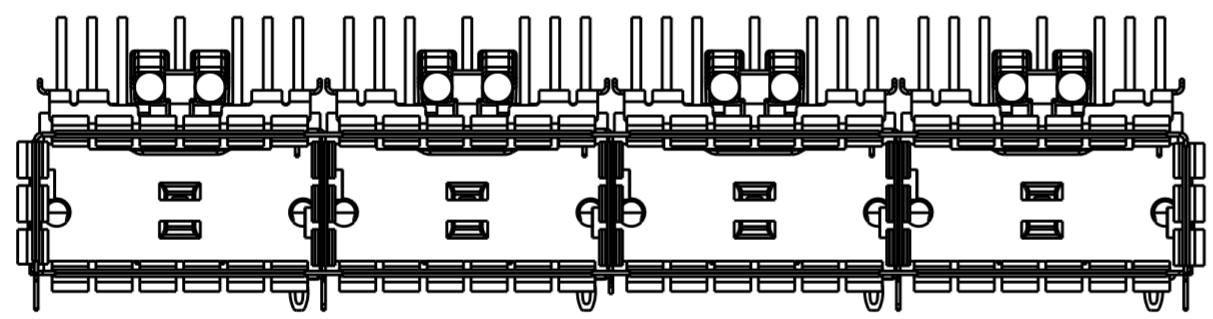

SCALE 2:1

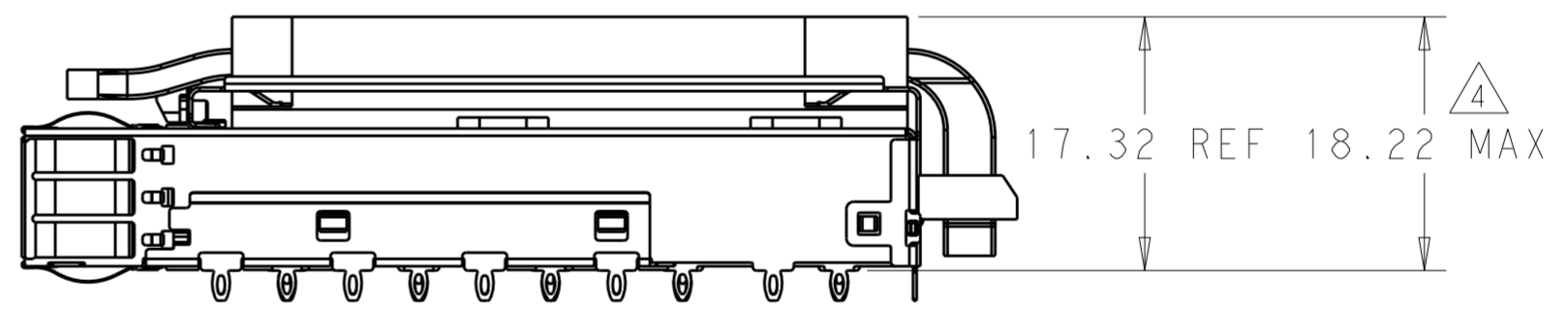

| | | | | |
|--|--|--|-------------------------------|---|
| THIS DRAWING IS A CONTROLLED DOCUMENT. | | DWN JASON YANG 04JUN2014 | TE Connectivity | |
| | | CHK SEAN HAN 07JUN2014 | | |
| DIMENSIONS: mm | | TOLERANCES UNLESS OTHERWISE SPECIFIED: | | NAME RECEPTACLE CAGE ASSEMBLY WITH HEAT SINKS AND LIGHT PIPES, THRU BEZEL, 1X4, QSFP28, SPRING |
| | | 0 PLC ± | PRODUCT SPEC 108-19428 | SIZE A2 |
| MATERIAL SEE NOTES | | 1 PLC ±0.25 | APPLICATION SPEC 114-32023 | CAGE CODE 00779 |
| | | 2 PLC ±0.2 | WEIGHT - | DRAWING NO C-2170747 |
| | | 3 PLC ± | CUSTOMER DRAWING | RESTRICTED TO - |
| | | 4 PLC ± | SCALE 1:1 | SHEET 5 OF 13 |
| | | ANGLES ± | | REV C |
| | | FINISH - | | |

THIS DRAWING IS UNPUBLISHED. RELEASED FOR PUBLICATION 20
 © COPYRIGHT 20 BY - ALL RIGHTS RESERVED.

| REVISIONS | | | | |
|-----------|-----|-------------|------|------|
| P | LTR | DESCRIPTION | DATE | APVD |
| - | | SEE SHEET 1 | - | - |
| | | | | |
| | | | | |

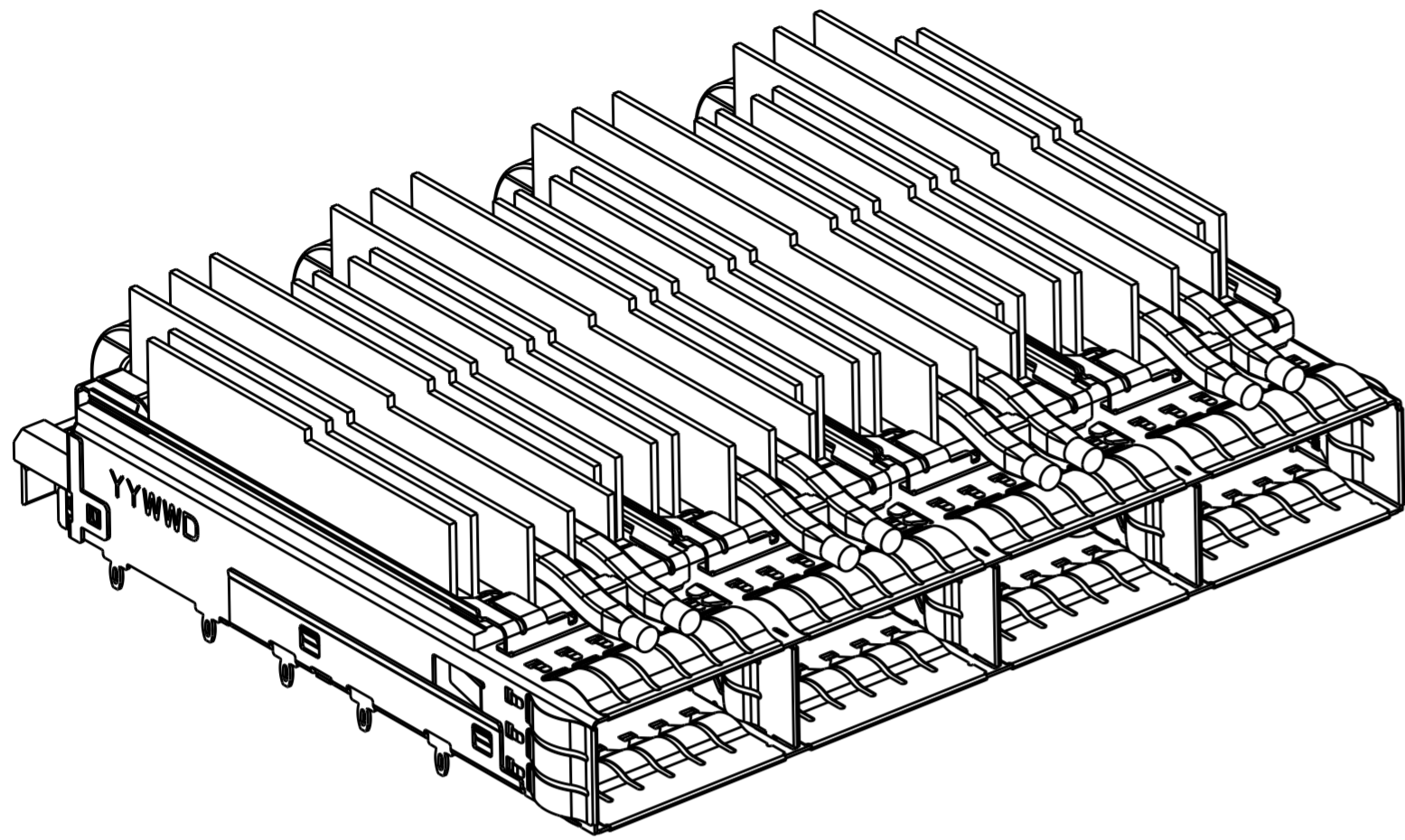

2-2170747-8 AS SHOWN
 WITH CUSTOMIZED HEAT SINK
 SCALE 2:1

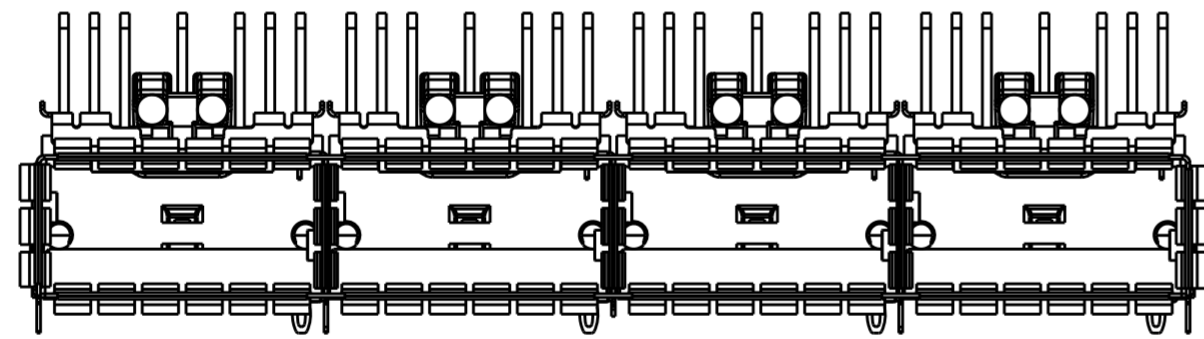

SCALE 2:1

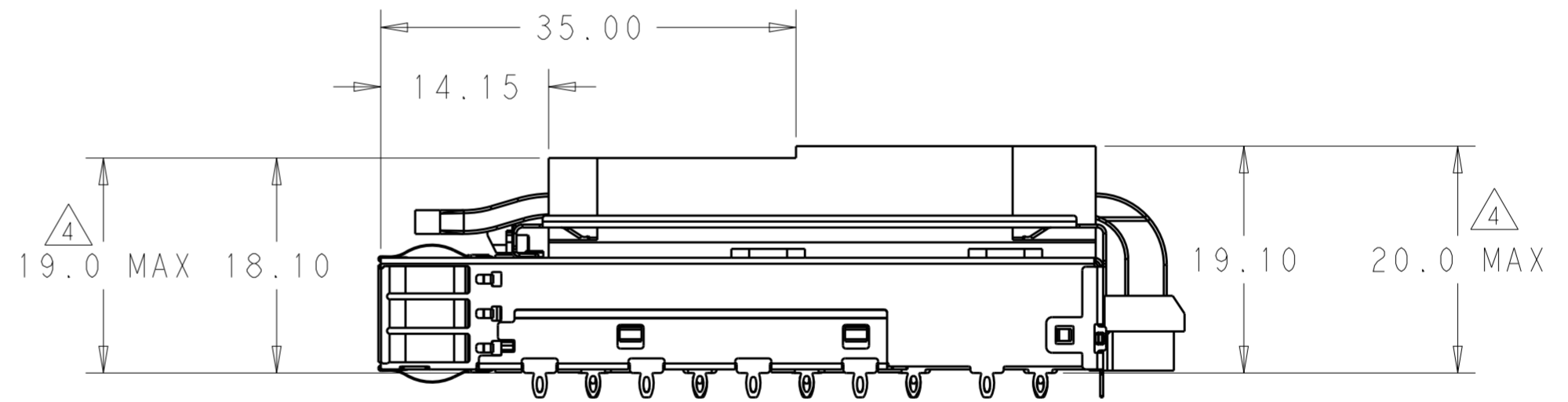

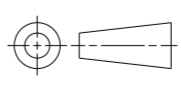
| | | | | |
|---|--|-----------------------------|---|----------------------------------|
| THIS DRAWING IS A CONTROLLED DOCUMENT. | | DWN 04JUN2014 JASON YANG |  TE Connectivity | |
| | | CHK 07JUN2014 SEAN HAN | | |
| DIMENSIONS: | | APVD - | | NAME |
| mm | | PRODUCT SPEC | | RECEPTACLE CAGE ASSEMBLY |
|  | | 108-19428 | | WITH HEAT SINKS AND LIGHT PIPES, |
| TOLERANCES UNLESS OTHERWISE SPECIFIED: | | APPLICATION SPEC | | THRU BEZEL, 1X4, QSFP28, SPRING |
| 0 PLC ±- | | 114-32023 | | SIZE CAGE CODE DRAWING NO |
| 1 PLC ±0.25 | | WEIGHT - | | A200779 C-2170747 |
| 2 PLC ±0.2 | | CUSTOMER DRAWING | | RESTRICTED TO |
| 3 PLC ±- | | SCALE 1:1 | | SHEET 6 OF 13 |
| 4 PLC ±- | | REV C | | |
| ANGLES ±- | | | | |
| FINISH | | | | |
| MATERIAL SEE NOTES | | | | |
| SEE NOTES | | | | |

THIS DRAWING IS UNPUBLISHED. RELEASED FOR PUBLICATION 20
 © COPYRIGHT 20 BY - ALL RIGHTS RESERVED.

| REVISIONS | | | | |
|-----------|-----|-------------|------|------|
| P | LTR | DESCRIPTION | DATE | APVD |
| - | | SEE SHEET 1 | - | - |
| | | | | |
| | | | | |

| | | | | |
|---------------|-------|-------------|-------------------|-------------------------|
| 1 | 16.0 | SAN | COATED QUAD LP | 5-2170747-2 |
| 0 | 23.0 | NETWORKING | QUAD LP | 4-2170747-6 |
| 0 | 16.0 | SAN | QUAD LP | 4-2170747-5 |
| 0 | 13.7 | PCI | QUAD LP | 4-2170747-4 |
| 1 | 23.0 | NETWORKING | QUAD LP | 4-2170747-3 |
| 1 | 16.0 | SAN | QUAD LP | 4-2170747-2 |
| 1 | 13.7 | PCI | QUAD LP | 4-2170747-1 |
| 1 | 20.3 | CUSTOMIZED | DUAL LP | 2-2170747-8 |
| 1 | 18.22 | CUSTOMIZED | DUAL LP | 2-2170747-7 |
| 0 | 23.0 | NETWORKING | DUAL LP | 2-2170747-6 |
| 0 | 16.0 | SAN | DUAL LP | 2-2170747-5 |
| 0 | 13.7 | PCI | DUAL LP | 2-2170747-4 |
| 1 | 23.0 | NETWORKING | DUAL LP | 2-2170747-3 |
| 1 | 16.0 | SAN | DUAL LP | 2-2170747-2 |
| 1 | 13.7 | PCI | DUAL LP | 2-2170747-1 |
| 0 | 14.45 | CUSTOMIZED | SINGLE LP | 2170747-9 |
| 0 | 18.05 | CUSTOMIZED | SINGLE LP | 2170747-8 |
| 0 | 18.05 | CUSTOMIZED | SINGLE LP | 2170747-7 ¹³ |
| 0 | 23.0 | NETWORKING | SINGLE LP | 2170747-6 |
| 0 | 16.0 | SAN | SINGLE LP | 2170747-5 |
| 0 | 13.7 | PCI | SINGLE LP | 2170747-4 |
| 1 | 23.0 | NETWORKING | SINGLE LP | 2170747-3 |
| 1 | 16.0 | SAN | SINGLE LP | 2170747-2 |
| 1 | 13.7 | PCI | SINGLE LP | 2170747-1 |
| # OF REAR PIN | DIM A | APPLICATION | LIGHT PIPE OPTION | PART NUMBER |

| | | | | |
|--|--|-------------------------------|---|--------------------|
| THIS DRAWING IS A CONTROLLED DOCUMENT. | | DWN 04 JUN 2014 JASON YANG | STE TE Connectivity | |
| | | CHK 07 JUN 2014 SEAN HAN | | |
| DIMENSIONS: mm | TOLERANCES UNLESS OTHERWISE SPECIFIED: 0 PLC ± 1 PLC ±0.25 2 PLC ±0.2 3 PLC ± 4 PLC ± ANGLES ± | APVD - | NAME RECEPTACLE CAGE ASSEMBLY WITH HEAT SINKS AND LIGHT PIPES, THRU BEZEL, 1X4, QSFP28, SPRING | |
| MATERIAL SEE NOTES | FINISH SEE NOTES | PRODUCT SPEC 108-19428 | SIZE 114-32023 | RESTRICTED TO - |
| | | APPLICATION SPEC 114-32023 | WEIGHT - | |
| CUSTOMER DRAWING | | SCALE 1:1 | SHEET 7 OF 13 | REV C |

THIS DRAWING IS UNPUBLISHED. RELEASED FOR PUBLICATION 20
 © COPYRIGHT 20 BY - ALL RIGHTS RESERVED.

| REVISIONS | | | | |
|-----------|-----|-------------|------|------|
| P | LTR | DESCRIPTION | DATE | APVD |
| - | - | SEE SHEET 1 | - | - |
| | | | | |
| | | | | |

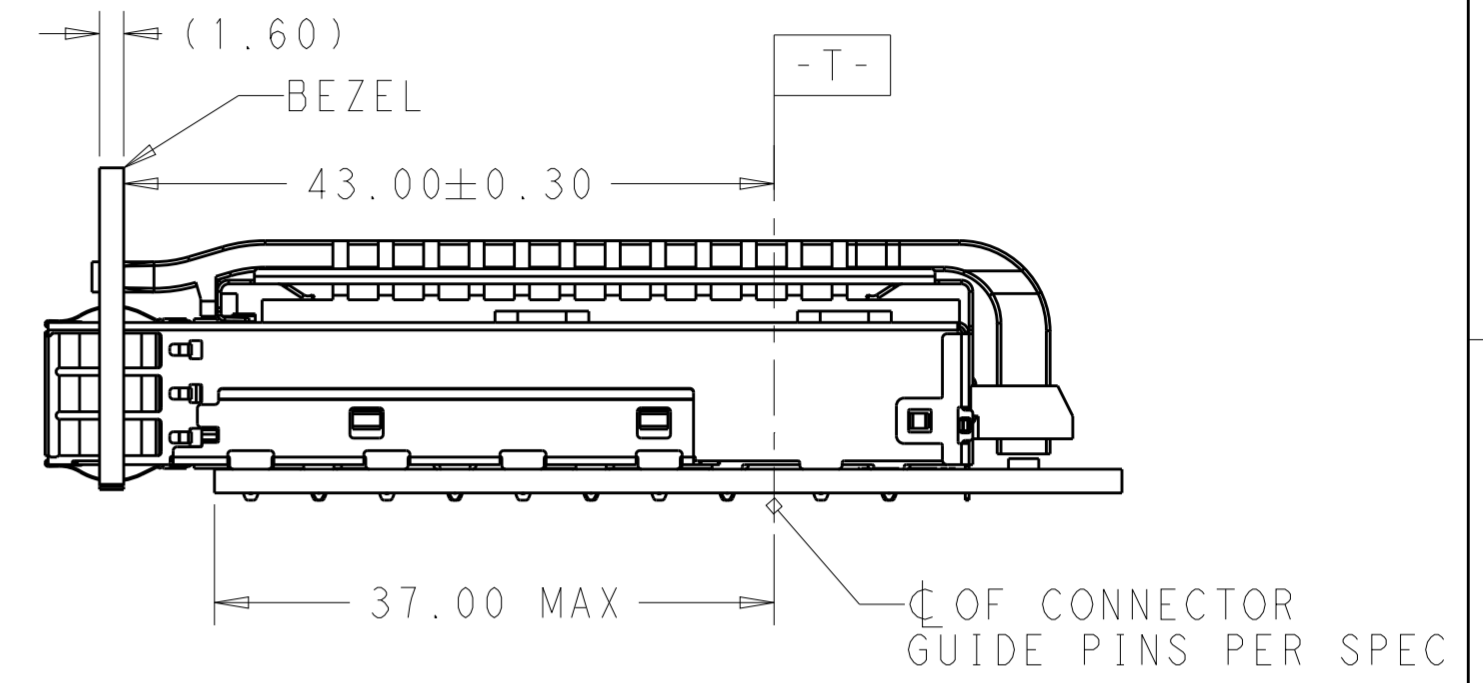
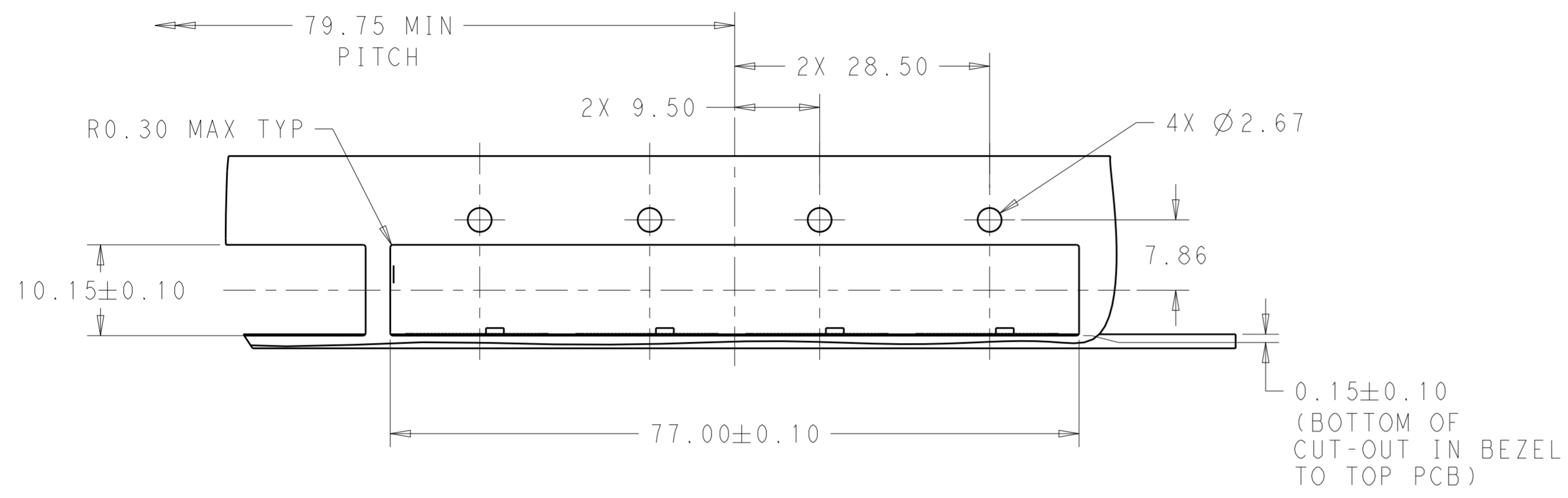

SINGLE SIDE MOUNTING
SCALE 2:1

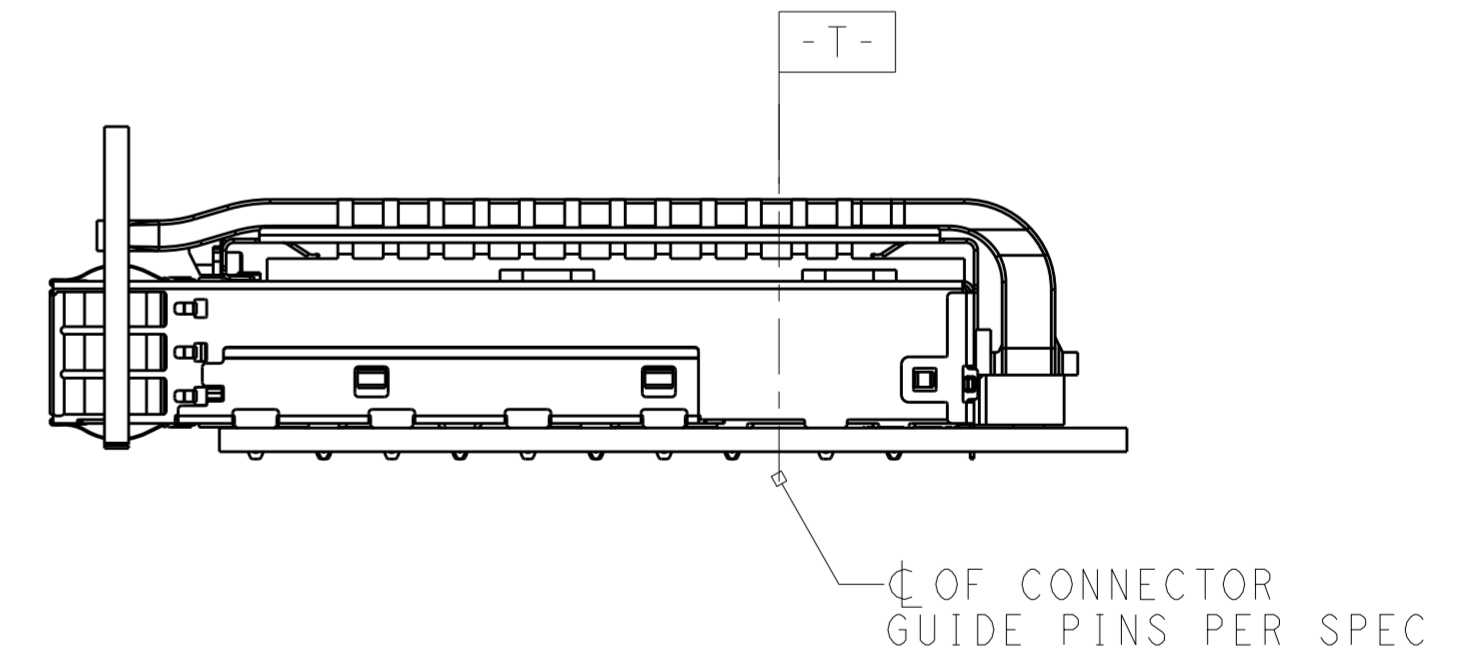
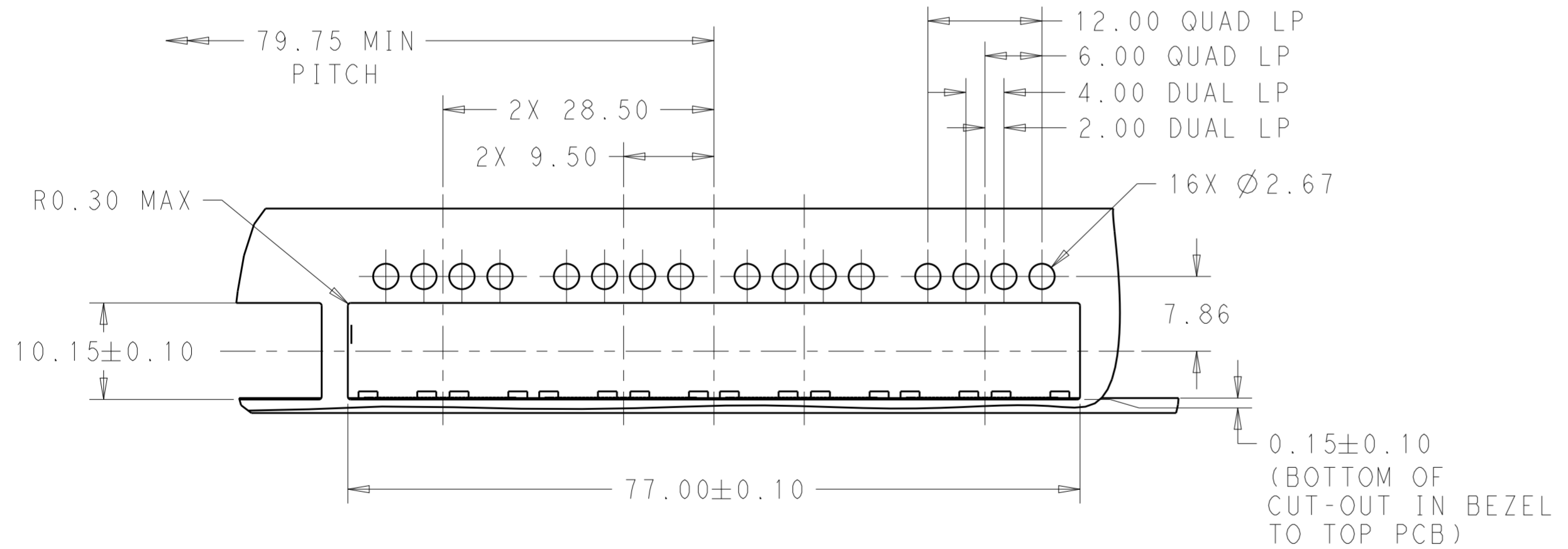

SINGLE SIDE MOUNTING
SCALE 2:1

| | | | | |
|--|--|-----------------------------|--|----------------------|
| THIS DRAWING IS A CONTROLLED DOCUMENT. | | DWN 04JUN2014 JASON YANG | STE TE Connectivity | |
| | | CHK 07JUN2014 SEAN HAN | | |
| DIMENSIONS: | TOLERANCES UNLESS OTHERWISE SPECIFIED: | APVD - | NAME RECEPTACLE CAGE ASSEMBLY WITH HEAT SINKS AND LIGHT PIPES, THRU BEZEL, 1X4, QSFP28, SPRING | |
| mm | 0 PLC ±- 1 PLC ±0.25 2 PLC ±0.2 3 PLC ±- 4 PLC ±- ANGLES ±- FINISH | PRODUCT SPEC 108-19428 | SIZE A200779 | DRAWING NO C-2170747 |
| MATERIAL SEE NOTES | SEE NOTES | APPLICATION SPEC 114-32023 | RESTRICTED TO | |
| | | WEIGHT - | SCALE 1:1 | SHEET 8 OF 13 |
| | | CUSTOMER DRAWING | REV C | |

THIS DRAWING IS UNPUBLISHED. RELEASED FOR PUBLICATION 20
 © COPYRIGHT 20 BY - ALL RIGHTS RESERVED.

| REVISIONS | | | | |
|-----------|-----|-------------|------|------|
| P | LTR | DESCRIPTION | DATE | APVD |
| - | - | SEE SHEET 1 | - | - |

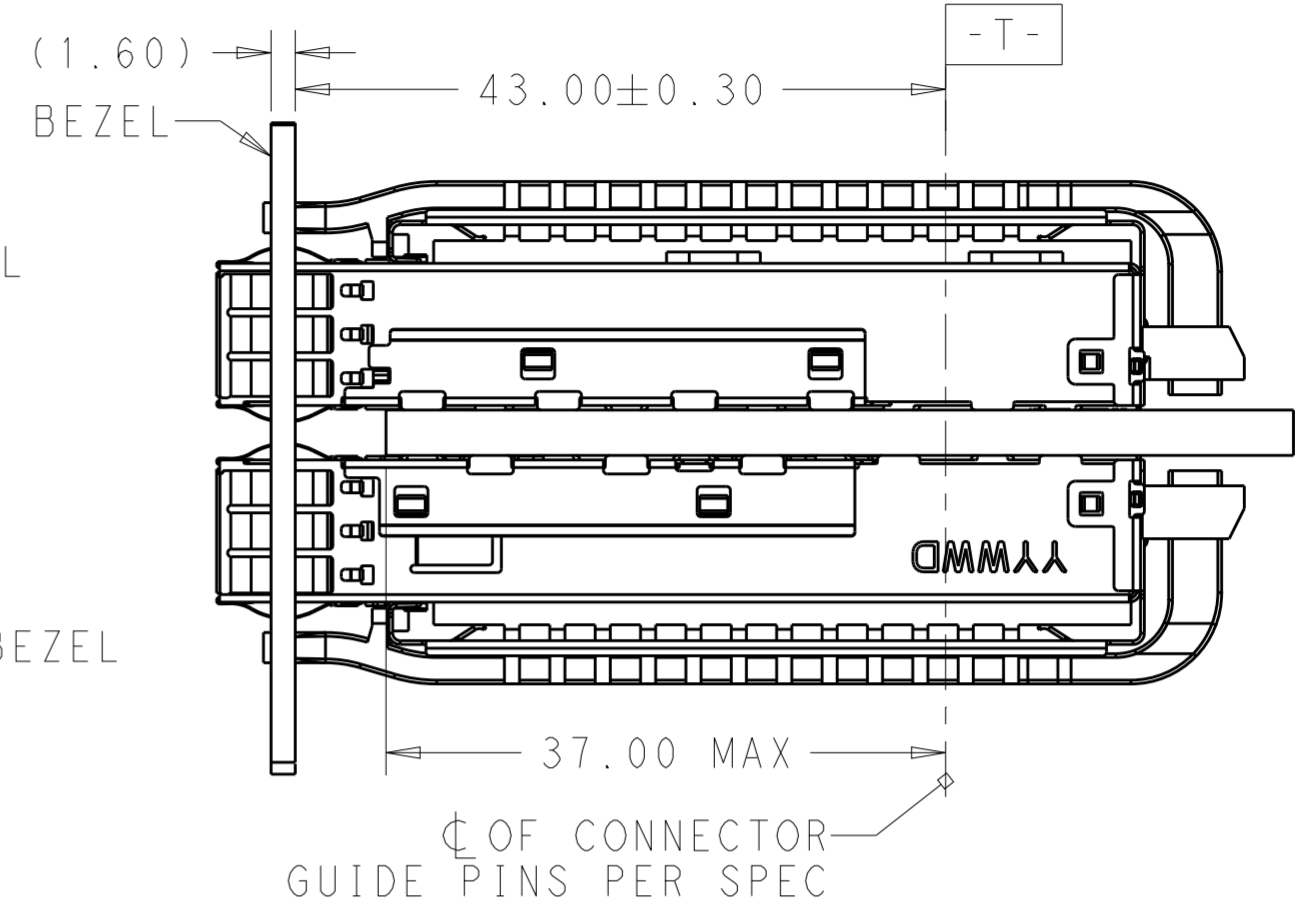
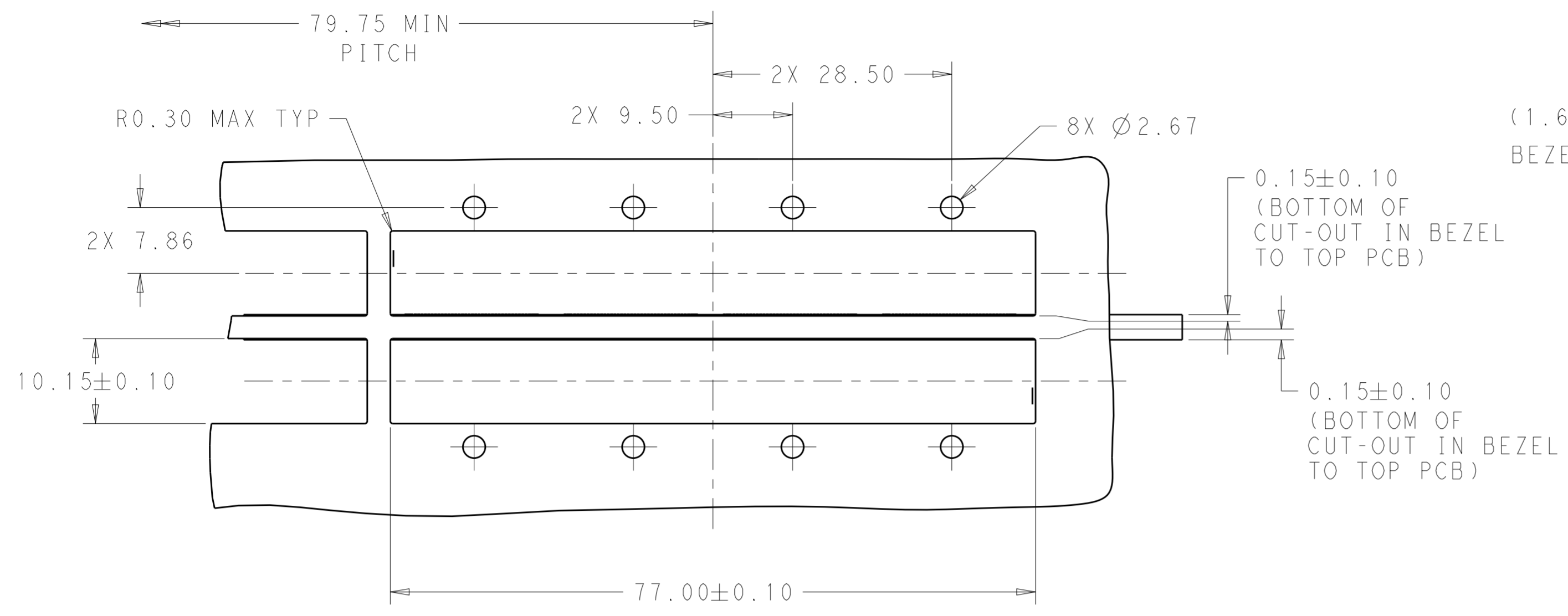

BELLY TO BELLY MOUNTING
SCALE 2:1

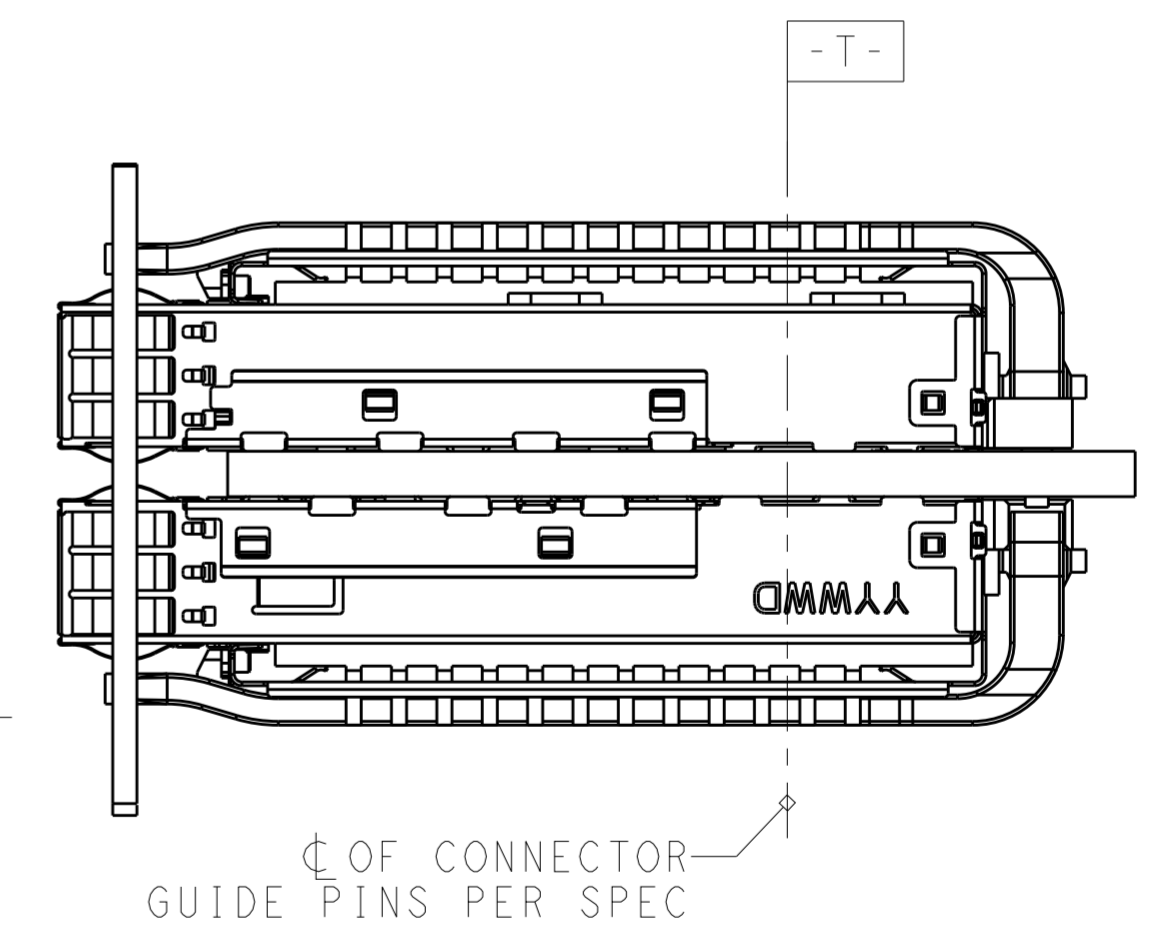
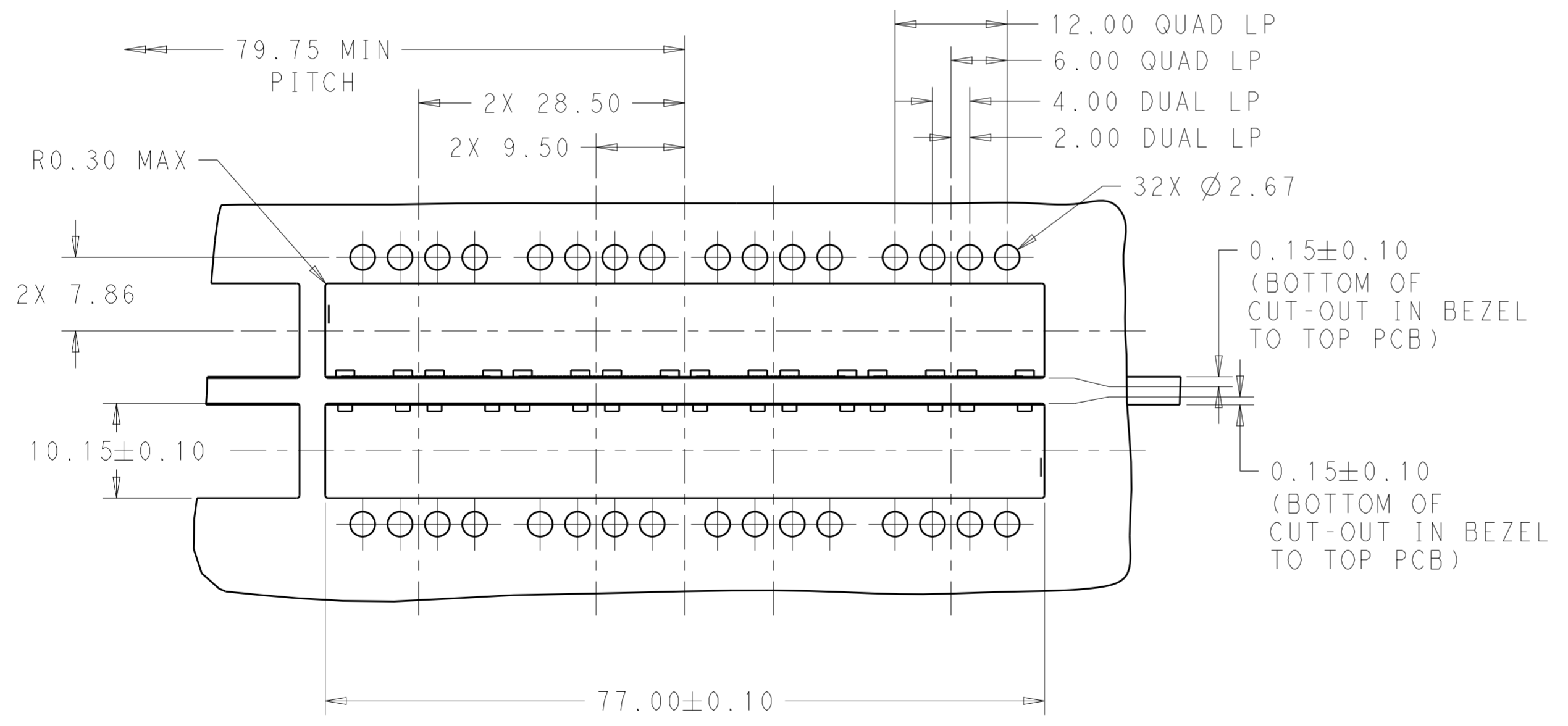

BELLY TO BELLY MOUNTING
SCALE 2:1

| | | | | |
|--|--|----------------------------------|-----------------|---|
| THIS DRAWING IS A CONTROLLED DOCUMENT. | | DWN JASON YANG 04 JUN 2014 | TE Connectivity | |
| | | CHK SEAN HAN 07 JUN 2014 | | |
| DIMENSIONS: | TOLERANCES UNLESS OTHERWISE SPECIFIED: | APVD | NAME | RECEPTACLE CAGE ASSEMBLY WITH HEAT SINKS AND LIGHT PIPES, THRU BEZEL, 1X4, QSFP28, SPRING |
| mm | 0 PLC ± 1 PLC ±0.25 2 PLC ±0.2 3 PLC ± 4 PLC ± ANGLES ± FINISH | PRODUCT SPEC 108-19428 | SIZE | |
| MATERIAL | SEE NOTES | APPLICATION SPEC 114-32023 | CAGE CODE | DRAWING NO |
| | | WEIGHT | A200779 | C-2170747 |
| | | CUSTOMER DRAWING | SCALE | SHEET |
| | | | 1:1 | 9 OF 13 |

THIS DRAWING IS UNPUBLISHED. RELEASED FOR PUBLICATION 20
 © COPYRIGHT 20 BY - ALL RIGHTS RESERVED.

| REVISIONS | | | | |
|-----------|-----|-------------|------|------|
| P | LTR | DESCRIPTION | DATE | APVD |
| - | - | SEE SHEET 1 | - | - |
| | | | | |
| | | | | |

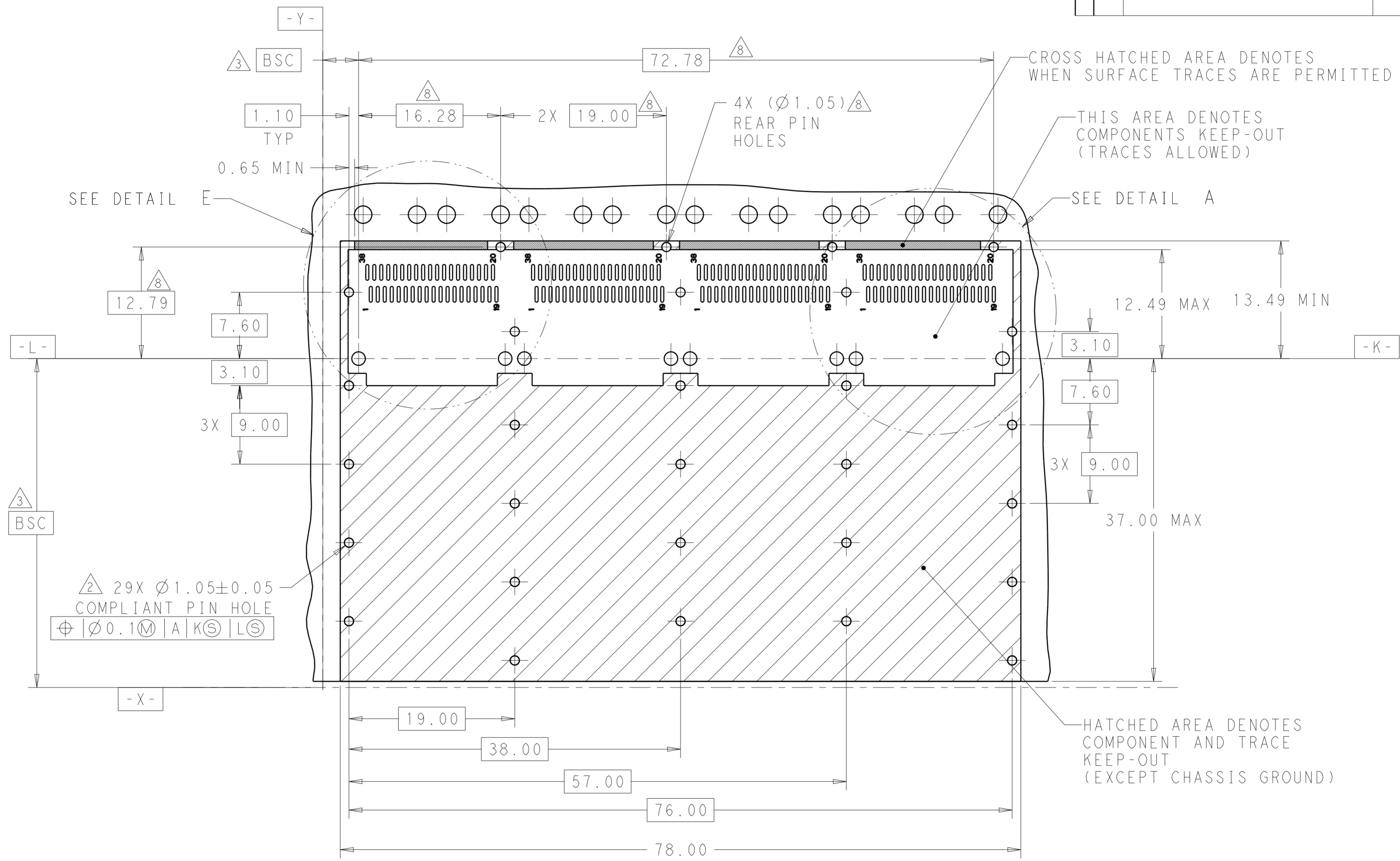

RECOMMENDED PCB LAYOUT
 SINGLE TYPE
 PCB TOLERANCE: ±0.05
 SCALE 3:1

| | | | | |
|--|--|--|-----------------|---|
| THIS DRAWING IS A CONTROLLED DOCUMENT. | | DWN 04JUN2014 JASON YANG | TE Connectivity | |
| | | CHK 07JUN2014 SEAN HAN | | |
| DIMENSIONS: mm | | TOLERANCES UNLESS OTHERWISE SPECIFIED: 0 PLC ± 1 PLC ±0.25 2 PLC ±0.2 3 PLC ± 4 PLC ± ANGLES ± FINISH SEE NOTES | | NAME RECEPTACLE CAGE ASSEMBLY WITH HEAT SINKS AND LIGHT PIPES, THRU BEZEL, 1X4, QSFP28, SPRING |
| MATERIAL SEE NOTES | | PRODUCT SPEC 108-19428 APPLICATION SPEC 114-32023 WEIGHT - | | SIZE A200779 |
| | | CUSTOMER DRAWING | | DRAWING NO C-2170747 RESTRICTED TO - |
| | | SCALE 1:1 | | SHEET 10 OF 13 REV C |

THIS DRAWING IS UNPUBLISHED. RELEASED FOR PUBLICATION 20
 © COPYRIGHT 20 BY - ALL RIGHTS RESERVED.

| REVISIONS | | | | |
|-----------|-----|-------------|------|------|
| P | LTR | DESCRIPTION | DATE | APVD |
| - | - | SEE SHEET 1 | - | - |
| | | | | |
| | | | | |

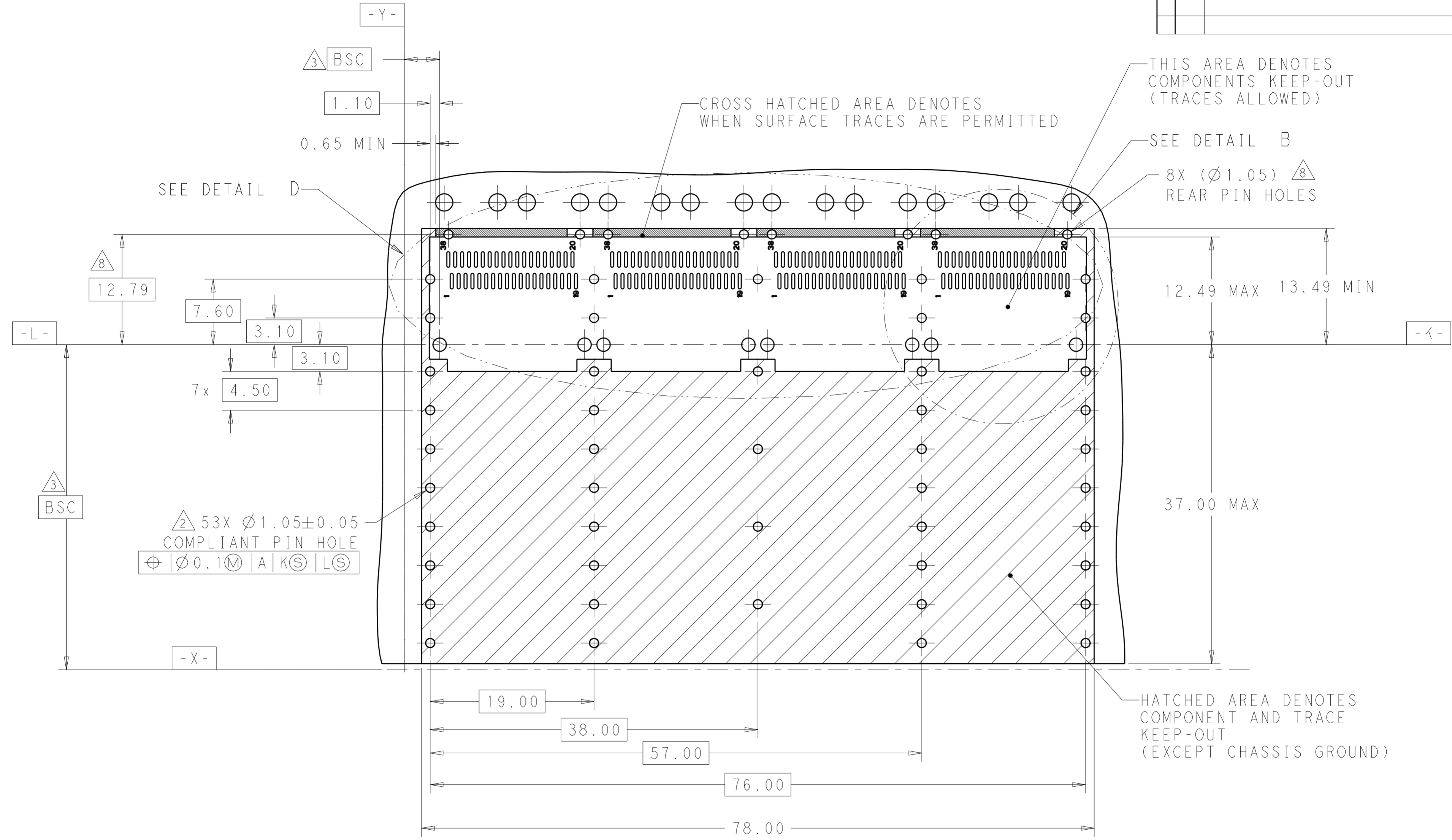

RECOMMENDED PCB LAYOUT
 BELLY TO BELLY TYPE
 PCB TOLERANCE: ±0.05
 SCALE 3:1

| | | | | |
|--|--|----------------------------------|---|---|
| THIS DRAWING IS A CONTROLLED DOCUMENT. | | DWN JASON YANG 04 JUN 2014 |  TE Connectivity | |
| | | CHK SEAN HAN 07 JUN 2014 | | |
| DIMENSIONS: mm | | APVD - | | NAME RECEPTACLE CAGE ASSEMBLY WITH HEAT SINKS AND LIGHT PIPES, THRU BEZEL, 1X4, QSFP28, SPRING |
| TOLERANCES UNLESS OTHERWISE SPECIFIED: 0 PLC ± 1 PLC ±0.25 2 PLC ±0.2 3 PLC ± 4 PLC ± ANGLES ± FINISH | | PRODUCT SPEC 108-19428 | | SIZE A200779 |
| MATERIAL SEE NOTES | | APPLICATION SPEC 114-32023 | | DRAWING NO C-2170747 |
| | | WEIGHT - | | RESTRICTED TO - |
| | | CUSTOMER DRAWING | | SCALE 1:1 SHEET 11 OF 13 REV C |

THIS DRAWING IS UNPUBLISHED. RELEASED FOR PUBLICATION 20
 © COPYRIGHT 20 BY - ALL RIGHTS RESERVED.

| REVISIONS | | | | |
|-----------|-----|-------------|------|------|
| P | LTR | DESCRIPTION | DATE | APVD |
| - | - | SEE SHEET 1 | - | - |
| | | | | |
| | | | | |

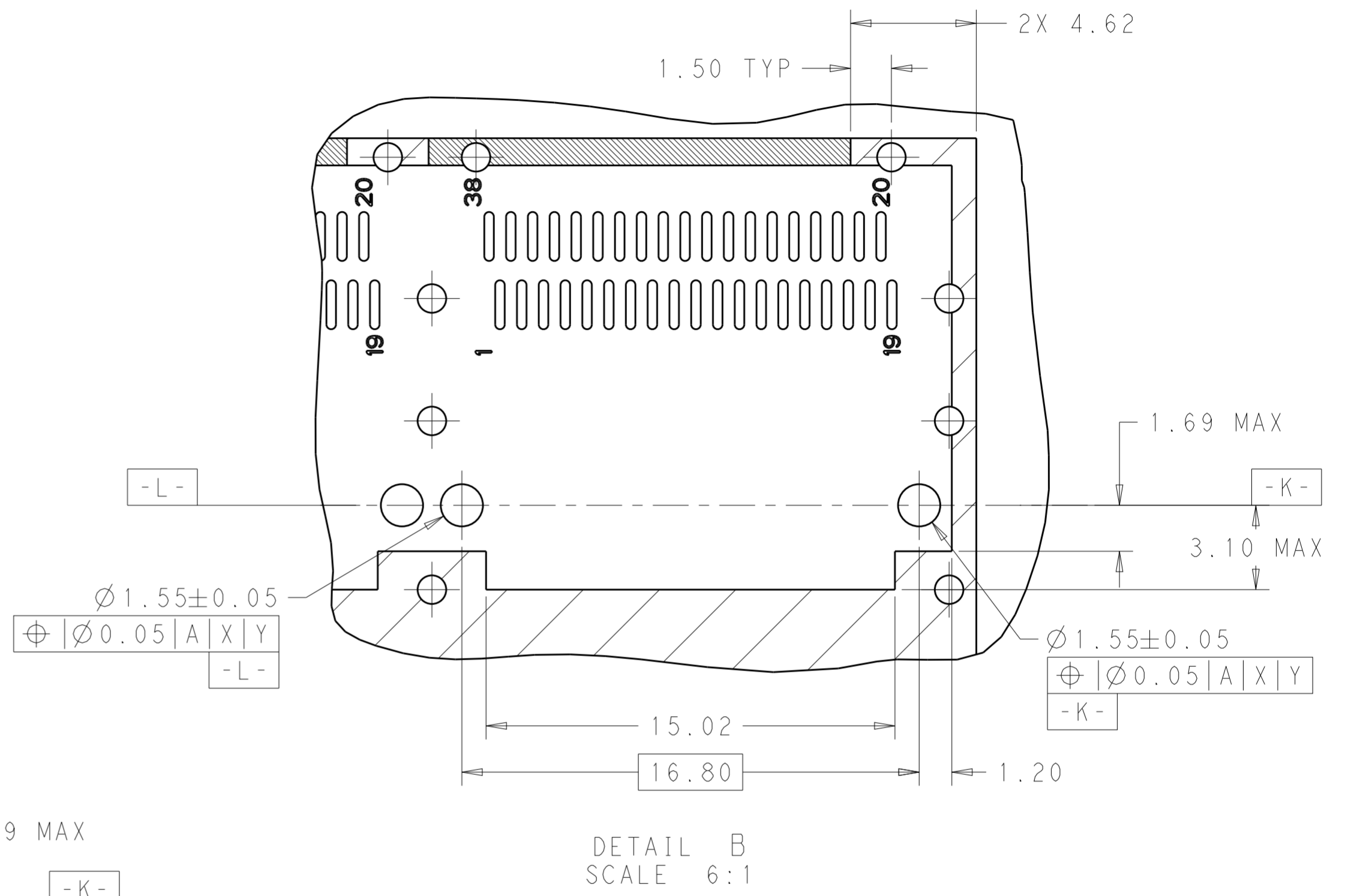
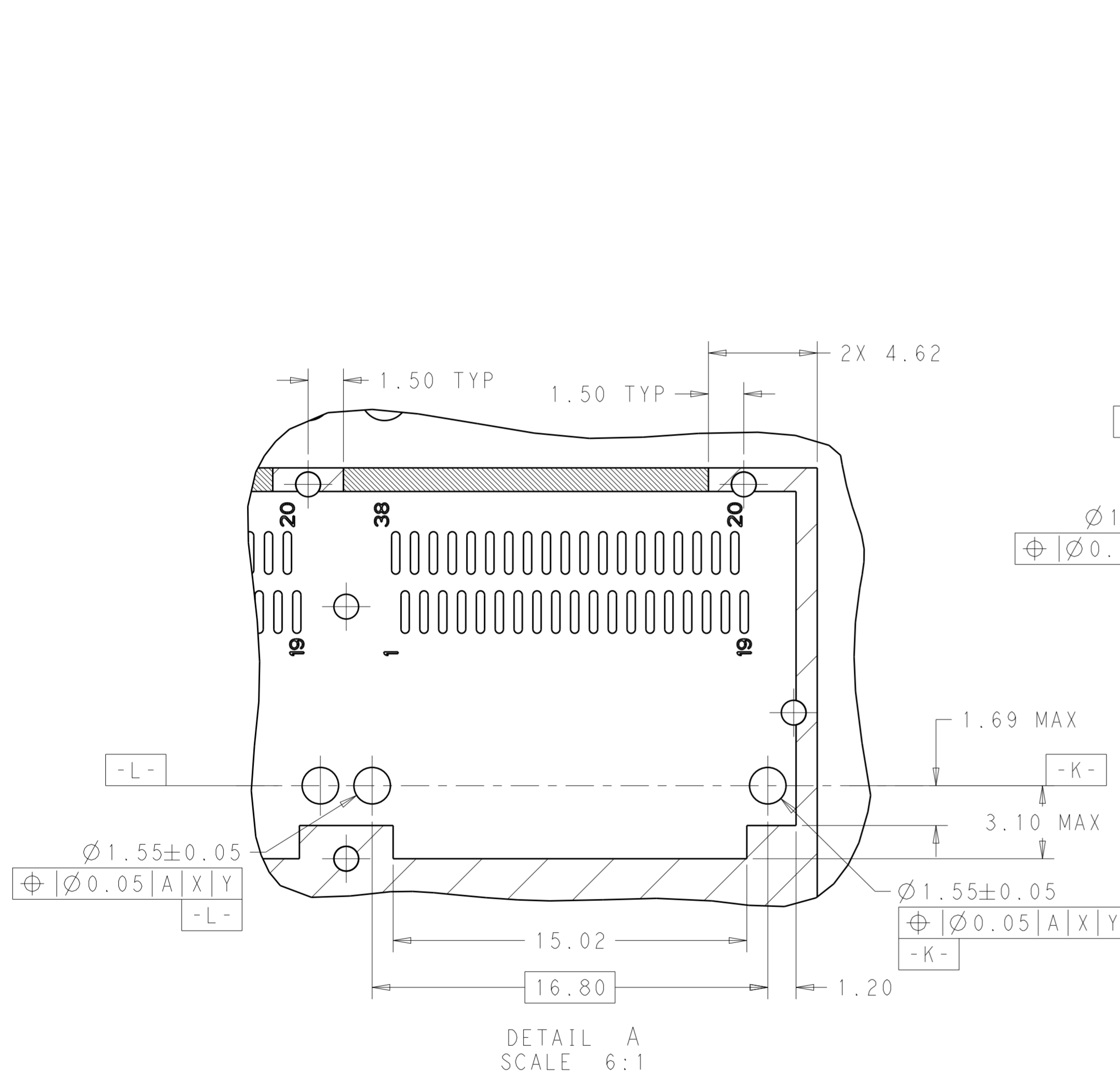

| | | | |
|--|--|----------------------------------|---|
| THIS DRAWING IS A CONTROLLED DOCUMENT. | | DWN JASON YANG 04 JUN 2014 | STE TE Connectivity |
| | | CHK SEAN HAN 07 JUN 2014 | |
| DIMENSIONS: mm | TOLERANCES UNLESS OTHERWISE SPECIFIED: 0 PLC ± 1 PLC ±0.25 2 PLC ±0.2 3 PLC ± 4 PLC ± ANGLES ± FINISH | APVD - | NAME RECEPTACLE CAGE ASSEMBLY WITH HEAT SINKS AND LIGHT PIPES, THRU BEZEL, 1X4, QSFP28, SPRING |
| MATERIAL SEE NOTES | SEE NOTES | PRODUCT SPEC 108-19428 | SIZE A200779 |
| | | APPLICATION SPEC 114-32023 | DRAWING NO C-2170747 |
| | | WEIGHT - | RESTRICTED TO - |
| | | CUSTOMER DRAWING | SCALE 1:1 SHEET 12 OF 13 REV C |

THIS DRAWING IS UNPUBLISHED. RELEASED FOR PUBLICATION 20
 © COPYRIGHT 20 BY - ALL RIGHTS RESERVED.

| REVISIONS | | | | |
|-----------|-----|-------------|------|------|
| P | LTR | DESCRIPTION | DATE | APVD |
| - | - | SEE SHEET 1 | - | - |
| | | | | |
| | | | | |

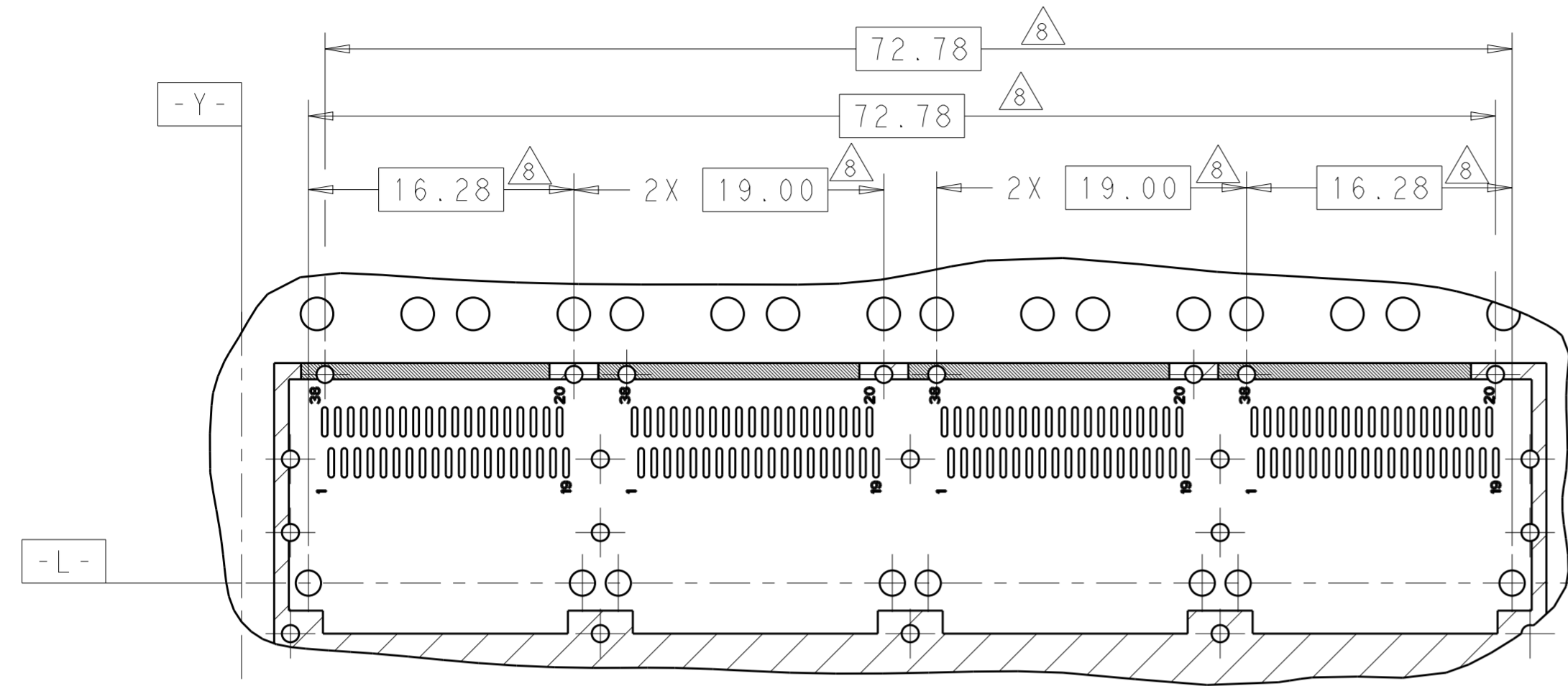

DETAIL D
SCALE 3:1

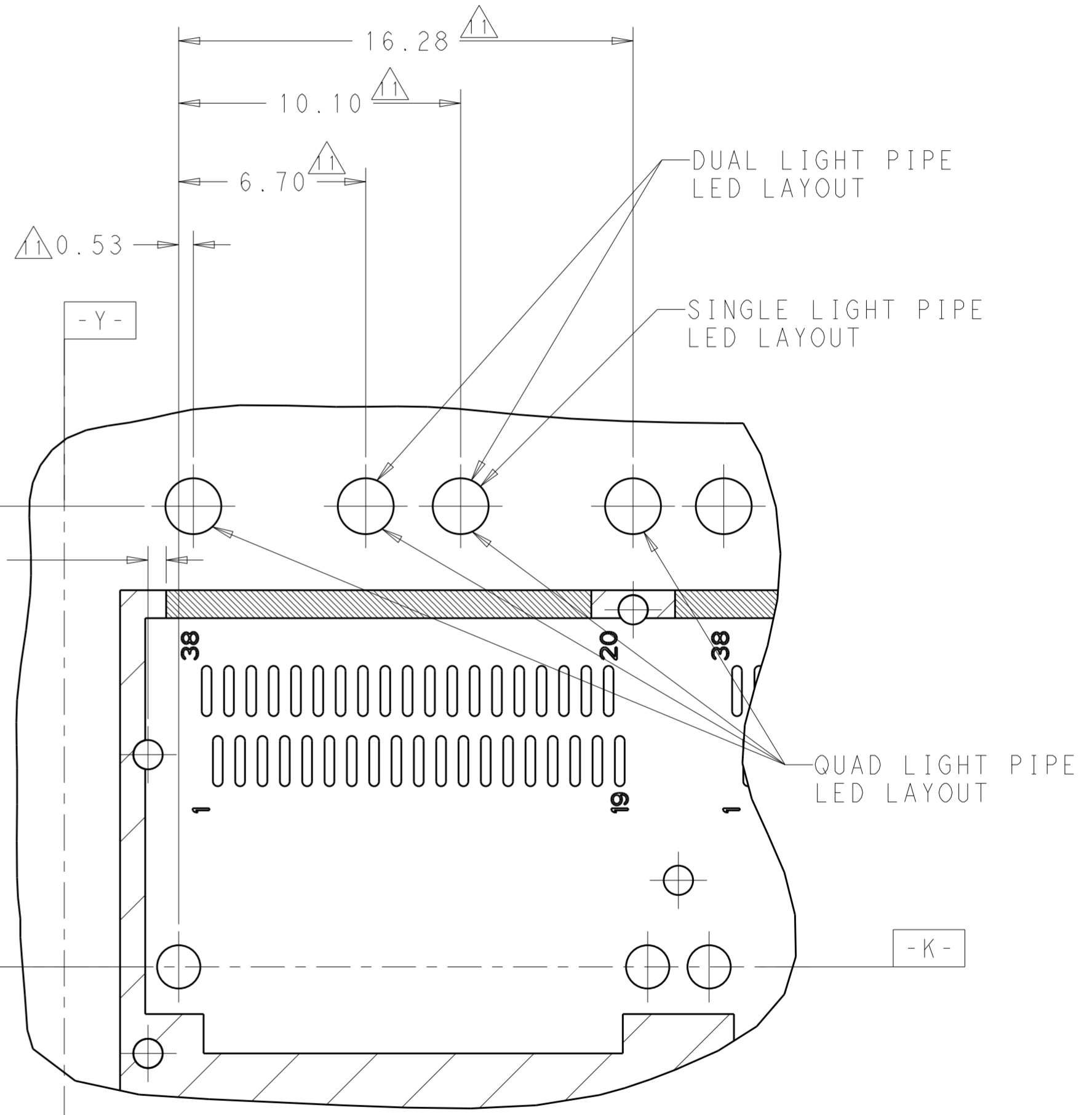

DETAIL E
SCALE 6:1

| | | | |
|--|--|-------------------------------|---|
| THIS DRAWING IS A CONTROLLED DOCUMENT. | | DWN 04 JUN 2014 JASON YANG | STE TE Connectivity |
| | | CHK 07 JUN 2014 SEAN HAN | |
| DIMENSIONS: | TOLERANCES UNLESS OTHERWISE SPECIFIED: | APVD - | NAME |
| mm | 0 PLC ± 1 PLC ±0.25 2 PLC ±0.2 3 PLC ± 4 PLC ± | PRODUCT SPEC | RECEPTACLE CAGE ASSEMBLY WITH HEAT SINKS AND LIGHT PIPES, THRU BEZEL, 1X4, QSFP28, SPRING |
| | ANGLES ± | APPLICATION SPEC | SIZE CAGE CODE DRAWING NO |
| MATERIAL | FINISH | 114-32023 | A200779 C-2170747 |
| SEE NOTES | SEE NOTES | WEIGHT - | RESTRICTED TO |
| | | CUSTOMER DRAWING | SCALE 1:1 SHEET 13 OF 13 REV C |