

H  
G  
F  
E  
D  
C  
B  
A

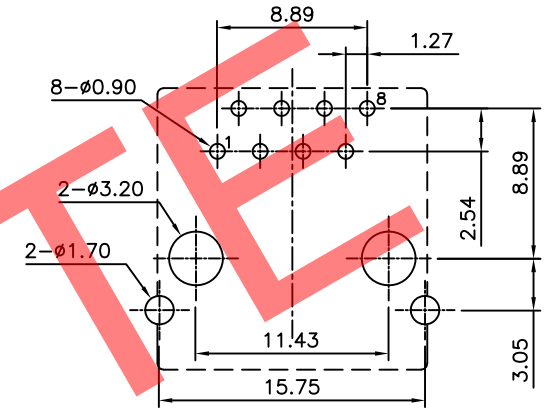
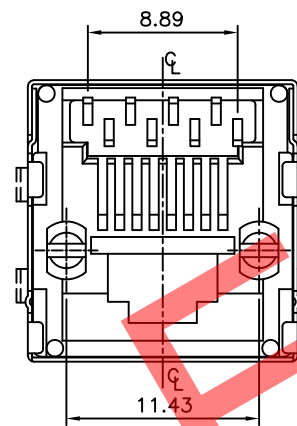
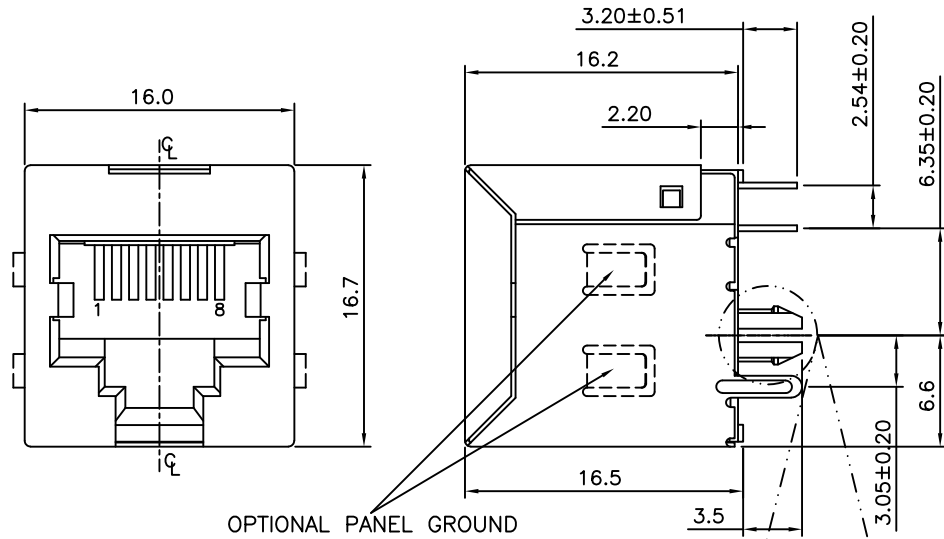

Specification 规格:

Electrical 电气规格:

- Voltage Rating 电压额定值: 125 V AC (RMS)
- Current Rating 电流额定值: 1.5 Amp
- Contact Resistance 接触电阻值: 30mΩ Max.
- Insulation Resistance 绝缘电阻值: 1000MΩ Min. @ 500 VDC
- Dielectric Strength 铁壳材料: 1000 VAC RMS 60Hz, 1 Min.
- Pin to Pin 针对针: 1000 VAC RMS 60Hz, 1 Min.
- Pin to Shield 针对铁壳: 1500 VAC RMS 60Hz, 1 Min.

Material 物料规格:

- Housing Material 塑胶外壳: High Temp Nylon UL94V-0 or Glass Filled Polyester, Black
- Contact Material 端子材料: Phosphor Bronze 0.35mm Thickness
- Shield Material: Copper C2680, Nickel Plated
- Plating 电镀规格: Gold Plating over Nickel
- Operating Life 使用寿命: 750 Cycles Min.
- PCB Retention Force Before Solder 焊接前保持力: 1 LB Min.
- PCB Retention Force After Solder 焊接后保持力: 10 LBS Min.

Environmental 环境的:

- Storage Temperature 储存温度: -40°C to +85°C
- Operation Temperature 使用温度: -40°C to +85°C

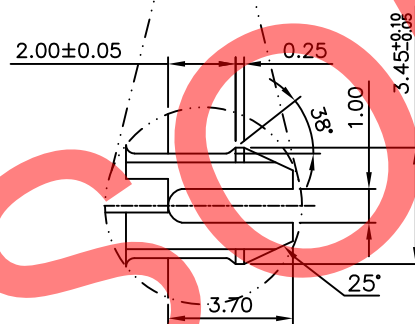

Ordering Grid

MJ3115 - 88 - X - X - X  Request Samples and Quotation

No. of Positions/  
Positions Loaded  
88=8/8

Panel Ground  
0=Without (Standard)  
1=With

Insulator Material  
N=High Temp Nylon (Standard)  
P=Glass Filled Polyester

Contact Plating  
2=6μ" Gold (Standard)  
4=30μ" Gold

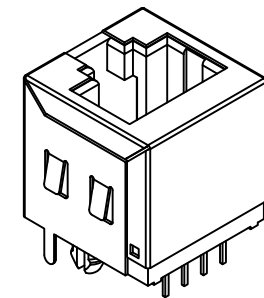

Part Number		Product Description	
MJ3115 - 8 Position		Modular Jack Connector, 8 Position, Category 3,	
Drawing Date		Vertical, Through Hole, Shielded, Optional Panel Ground	
11th May 2010			
By	CC	Tolerances (Except as Noted)	Units:
Detail	Obsolete	Length	Metric (mm)
Revision	X	X. ± 0.20	
Date	09/08/22	X.X ± 0.15	
		X.XX ± 0.10	± 5°
		This drawing is confidential and copyright of Global Connector Technology, Ltd (GCT). This drawing must not be copied or disclosed without written consent. E & OE	



Not to Scale Drawn By AJO Sheet No. 1/2

1. Packing Material 包材 - Tray 1 PC

Quantity 數量 - 1\*60=60 PCS

Tray: Body and Cover 真空盒上下蓋各 - 1PC Each  
Label 标签 - 1 PC

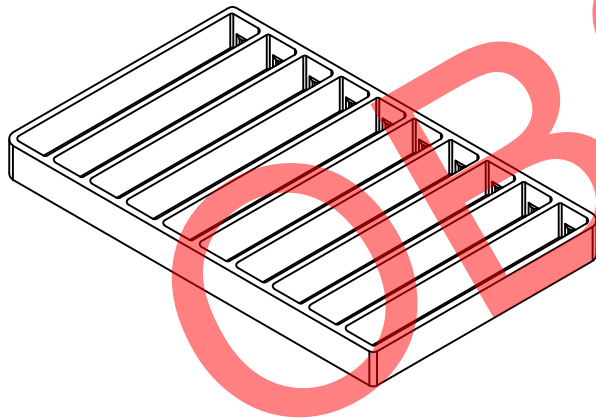
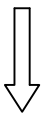
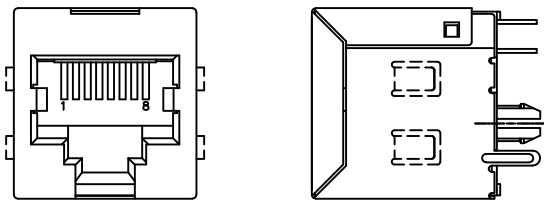



2. Packing Material 包材 - Carton - 380\*315\*290 - 1 PC

Quantity 數量 - 60\*24=1440 PCS

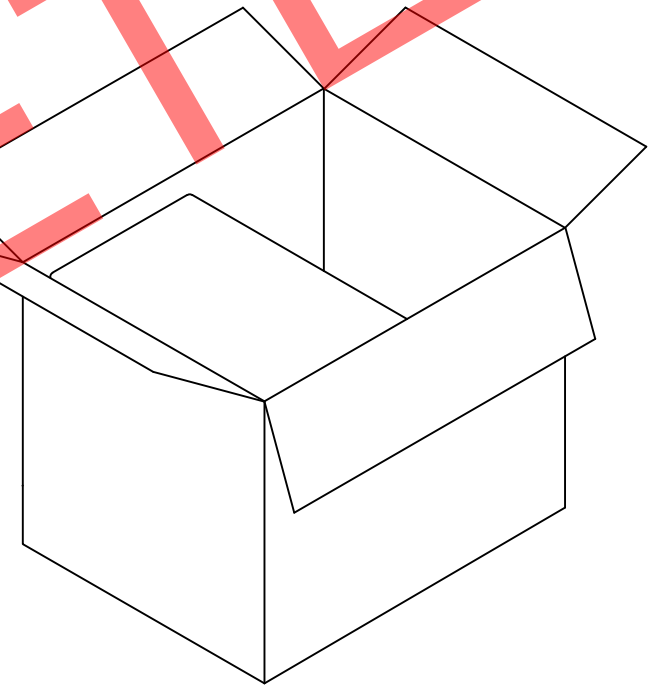
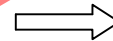
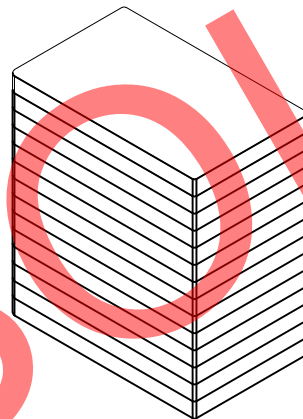
Part Number 零部件料号	Net Weight 淨重	Gross Weight 毛重	Q'TY 數量
MJ3115-88-X-X-X	9.93Kg	10.25Kg	1400



Part Number MJ3115 - 8 Position		Product Description Modular Jack Connector, 8 Position, Category 3, Vertical, Through Hole, Shielded, Optional Panel Ground		 www.gct.co
Drawing Date 11th May 2010				
By CC	Detail Obsolete	Tolerances (Except as Noted) Length	Angle	Units: Metric (mm)
Revision X	Date 09/08/22			 This drawing is confidential and copyright of Global Connector Technology, Ltd (GCT). This drawing must not be copied or disclosed without written consent. E & OE
		 3rd Angle Projection		Not to Scale Drawn By AJO Sheet No. 2/2