



QUICKSWITCH® PRODUCTS HIGH-SPEED CMOS 10-BIT QUICKSWITCH WITH PRECHARGED OUTPUTS

IDTQS3800

FEATURES:

- 5Ω bidirectional switches connect inputs to outputs
- Zero propagation delay, zero ground bounce
- Undershoot clamp diodes on all switch and control inputs
- Outputs precharge voltage to minimize signal distortion during live insertion
- TTL-compatible input and output levels
- Available in QSOP package

DESCRIPTION:

The QS3800 is a 10-bit high-speed CMOS bus switch controlled by a single enable (\overline{ON}) input. When \overline{ON} is low, the switch is on and port A is connected to port B. When \overline{ON} is high, the switch between port A and port B is open and port B is precharged to the bias voltage. The low ON resistance (5Ω) of the QS3800 allows inputs to be connected to outputs without adding propagation delay and without generating additional noise. The QS3800 also precharges the B port to a user-selectable bias voltage to minimize live insertion noise, which is useful in VME bus applications.

The QS3800 is characterized for operation at -40°C to +85°C.

FUNCTIONAL BLOCK DIAGRAM

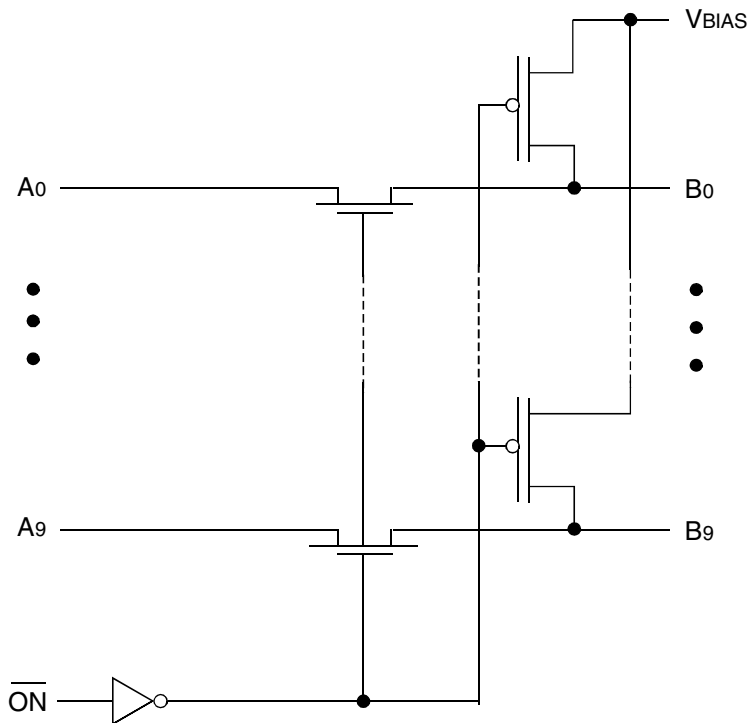

PIN CONFIGURATION

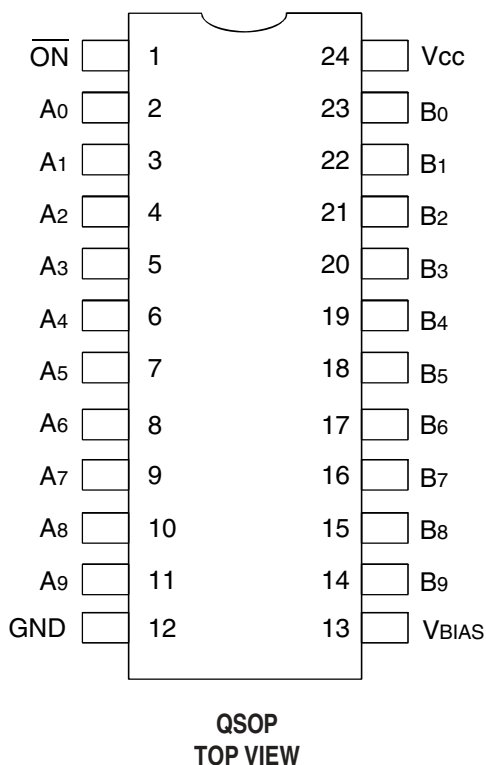

ABSOLUTE MAXIMUM RATINGS⁽¹⁾

| Symbol | Description | Max | Unit |
|----------------------|--------------------------------------|-----------------|------|
| VTERM ⁽²⁾ | Supply Voltage to Ground | -0.5 to +7 | V |
| VBIAS | Bias Voltage Range | -0.5 to Vcc | V |
| VTERM ⁽³⁾ | DC Input Voltage V _{IN} | -0.5 to Vcc+0.5 | V |
| VAC | AC Input Voltage (pulse width ≤20ns) | -3 | V |
| I _{OUT} | DC Output Current | 120 | mA |
| | Input Clamp Current | -50 | mA |
| P _{MAX} | Maximum Power Dissipation | 0.5 | W |
| T _{STG} | Storage Temperature | -65 to +150 | °C |

NOTES:

- Stresses greater than those listed under ABSOLUTE MAXIMUM RATINGS may cause permanent damage to the device. This is a stress rating only and functional operation of the device at these or any other conditions above those indicated in the operational sections of this specification is not implied. Exposure to absolute maximum rating conditions for extended periods may affect reliability.
- V_{cc} terminals.
- All terminals except V_{cc}.

CAPACITANCE (T_A = +25°C, f = 1MHz, V_{IN} = 0V, V_{OUT} = 0V)

| Pins | Typ. | Max. ⁽¹⁾ | Unit |
|-----------------------------------|------|---------------------|------|
| Control Inputs | 3 | 5 | pF |
| Quickswitch Channels (Switch OFF) | 5 | 7 | pF |

NOTE:

- This parameter is guaranteed but not production tested.

PIN DESCRIPTION

| Pin Names | I/O | Description |
|---------------------------------|-----|-------------------|
| A ₀ - A ₉ | I/O | Bus A |
| B ₀ - B ₉ | I/O | Bus B |
| $\overline{\text{ON}}$ | I | Bus Switch Enable |
| V _{BIAS} | I | Bias Voltage |

FUNCTION TABLE⁽¹⁾

| $\overline{\text{ON}}$ | B ₀ - B ₉ | Function |
|------------------------|---------------------------------|------------|
| L | A ₀ - A ₉ | Connect |
| H | V _{BIAS} | Disconnect |

NOTE:

- H = HIGH Voltage Level
L = LOW Voltage Level

DC ELECTRICAL CHARACTERISTICS OVER OPERATING RANGE

Following Conditions Apply Unless Otherwise Specified:

Industrial: $T_A = -40^{\circ}\text{C}$ to $+85^{\circ}\text{C}$, $V_{CC} = 5\text{V} \pm 10\%$

| Symbol | Parameter | Test Conditions | Min. | Typ. ⁽¹⁾ | Max. | Unit |
|------------|--|---|------|---------------------|----------|---------------|
| V_{IH} | Input HIGH Voltage | Guaranteed Logic HIGH for Control Pins | 2 | — | — | V |
| V_{IL} | Input LOW Voltage | Guaranteed Logic LOW for Control Pins | — | — | 0.8 | V |
| V_{BIAS} | Bias Voltage | $V_{CC} = 5\text{V}$ | 1.3 | — | V_{CC} | V |
| I_O | Bias Current | $V_{CC} = 4.5\text{V}$, $V_{BIAS} = 2.4\text{V}$, $V_O = 0$, $\overline{ON} = \text{HIGH}$ | 0.25 | — | — | mA |
| I_{IN} | Input Leakage Current (Control Inputs) | $0\text{V} \leq V_{IN} \leq V_{CC}$ | — | — | ± 1 | μA |
| I_{OZ} | Off-State Current (Hi-Z) | $0\text{V} \leq V_{OUT} \leq V_{CC}$ | — | — | ± 1 | μA |
| RON | Switch ON Resistance | $V_{CC} = \text{Min.}$, $V_{IN} = 0\text{V}$, $I_{ON} = 30\text{mA}$ | — | 5 | 7 | Ω |
| | | $V_{CC} = \text{Min.}$, $V_{IN} = 2.4\text{V}$, $I_{ON} = 15\text{mA}$ | — | 10 | 15 | |

NOTE:

1. Typical values are at $V_{CC} = 5\text{V}$ and $T_A = 25^{\circ}\text{C}$.

TYPICAL ON RESISTANCE vs V_{IN} AT $V_{CC} = 5\text{V}$

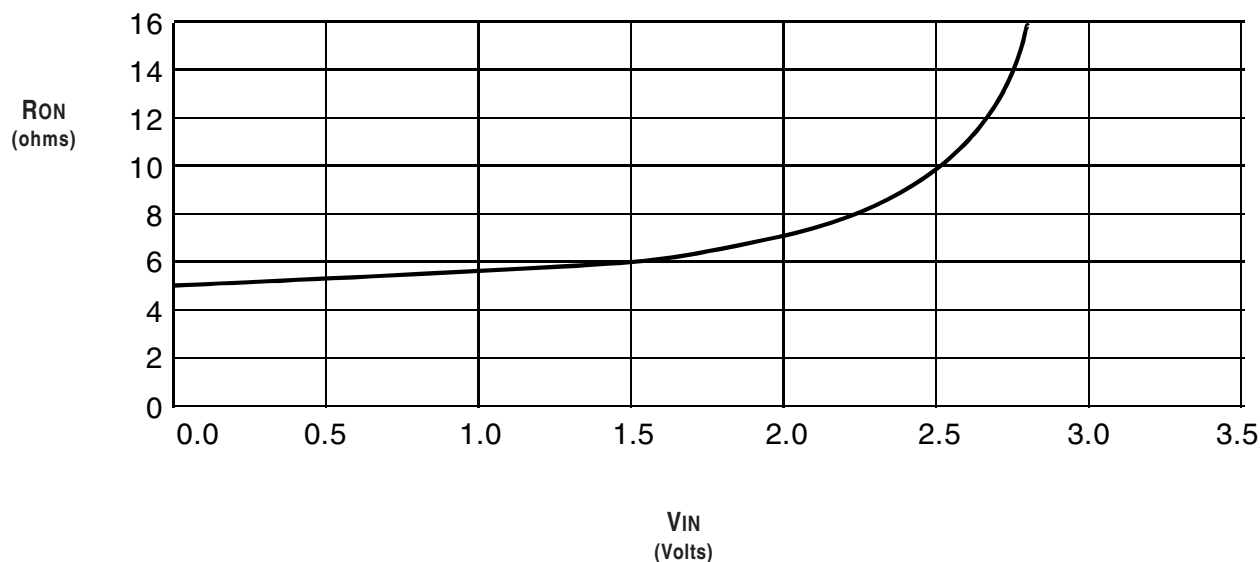

POWER SUPPLY CHARACTERISTICS

| Symbol | Parameter | Test Conditions ⁽¹⁾ | Typ. ⁽²⁾ | Max. | Unit |
|------------------|---|--|---------------------|------|--------|
| I _{CCQ} | Quiescent Power Supply Current | V _{CC} = Max., V _{IN} = GND or V _{CC} , f = 0 | 0.2 | 3 | μA |
| ΔI _{CC} | Power Supply Current per Input HIGH ⁽³⁾ | V _{CC} = Max., V _{IN} = 3.4V, f = 0 | — | 2.5 | mA |
| I _{CCD} | Dynamic Power Supply Current per MHz ⁽⁴⁾ | V _{CC} = Max., A and B Pins Open, Data Inputs = GND, Control Input Toggling @ 50% Duty Cycle | — | 0.25 | mA/MHz |

NOTES:

- For conditions shown as Min. or Max., use the appropriate values specified under DC Electrical Characteristics.
- Typical values are at V_{CC} = 5V and T_A = 25°C.
- Per TTL-driven input (V_{IN} = 3.4V, control inputs only). A and B pins do not contribute to ΔI_{CC}.
- This current applies to the control inputs only and represents the current required to switch internal capacitance at the specified frequency. The A and B inputs generate no significant AC or DC currents as they transition. This parameter is guaranteed but not production tested.

SWITCHING CHARACTERISTICS OVER OPERATING RANGE

T_A = -40°C to +85°C, V_{CC} = 5V ± 10%

C_{LOAD} = 50pF, R_{LOAD} = 500Ω unless otherwise noted.

| Symbol | Parameter | Test Conditions | Min. ⁽¹⁾ | Typ. | Max. | Unit |
|--------------------------------------|---|---|---------------------|------|------|------|
| t _{PLH} t _{PHL} | Data Propagation Delay ^(1,2) A to B, B to A | | — | 0.25 | — | ns |
| t _{PZL} t _{PZH} | Switch Turn-On Delay ON to A or B | V _{BIAS} = 3V V _{BIAS} = GND | 1.5 | — | 7.5 | ns |
| t _{PLZ} t _{PHZ} | Switch Turn-Off Delay ⁽¹⁾ ON to A or B | V _{BIAS} = 3V V _{BIAS} = GND | 1.5 | — | 6.5 | ns |

NOTES:

- This parameter is guaranteed but not production tested.
- The bus switch contributes no propagation delay other than the RC delay of the ON resistance of the switch and the load capacitance. The time constant for the switch alone is of the order of 0.25ns at C_L = 50pF. Since this time constant is much smaller than the rise and fall times of typical driving signals, it adds very little propagation delay to the system. Propagation delay of the bus switch, when used in a system, is determined by the driving circuit on the driving side of the switch and its interaction with the load on the driven side.

ORDERING INFORMATION

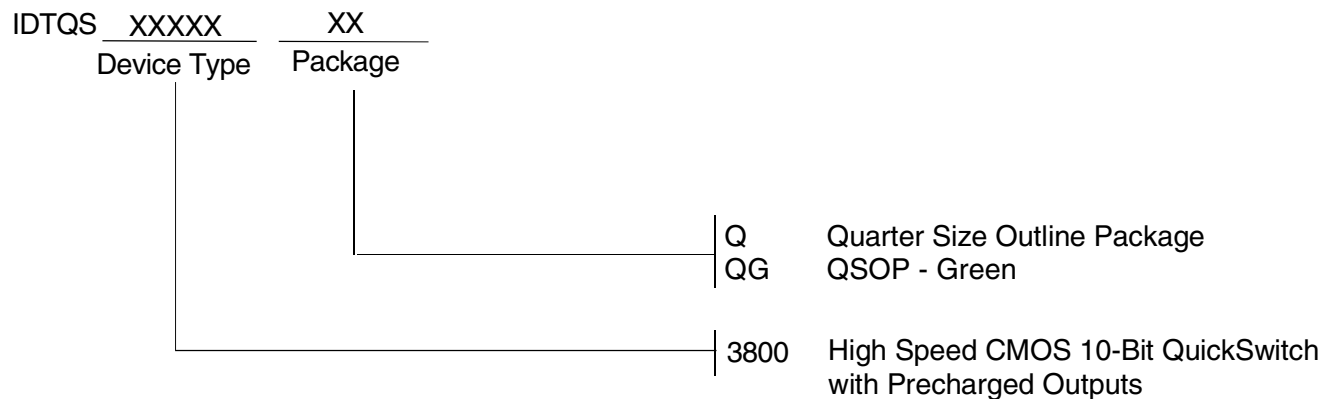

CORPORATE HEADQUARTERS
6024 Silver Creek Valley Road
San Jose, CA 95138

for SALES:
800-345-7015 or 408-284-8200
fax: 408-284-2775
www.idt.com

for Tech Support:
logichelp@idt.com