

MINI MCR-2-UI-I-OLP(-PT)(-C)



Output loop-powered 2-way isolator

Data sheet
106298_en_02

© PHOENIX CONTACT 2016-02-29

1 Description

The 2-way output loop-powered isolator with plug-in connection technology, which can be configured using DIP switches, is used for the electrical isolation, conversion, and filtering of unipolar and bipolar standard and normalized signals.

The device allows operation on an active analog input module.

The device is powered via the current loop of the controller.

On the input side, standard analog signals and non-standard analog signals can be connected, ranging from 2 mA or 50 mV up to 40 mA or 30 V. These are converted to a 4 mA ... 20 mA signal.

There is no need for adjustment following a measuring range changeover.

Features

- Output loop-powered 2-way isolator with plug-in connection technology
- Approval for Ex-zone 2 (nA)
- 74 input ranges can be set via DIP switches
- Screw or push-in connection available
- Reinforced insulation according to IEC 61010-1



WARNING: Correct usage in potentially explosive areas

The module is a category 3 item of electrical equipment. It is absolutely vital to follow the instructions provided here during installation and observe the information in the "Safety regulations and installation notes".



This device offers the option of NFC communication.

You can use the MINI Analog Pro Smartphone app to call-up DIP switch setting help and comprehensive module information via the NFC interface of your Smartphone.

The MINI Analog Pro Smartphone app is available to you free.



Make sure you always use the latest documentation.

It can be downloaded from the product at phoenixcontact.net/products.

This document is valid for the products listed in the "Ordering data".

2	Table of contents	
1	Description	1
2	Table of contents	2
3	Ordering data	3
4	Technical data	5
5	Safety regulations and installation notes.....	8
	5.1 Installation notes	8
	5.2 Installation in Zone 2.....	8
	5.3 UL Notes	8
6	Installation	9
	6.1 Connection notes	9
	6.2 Structure	9
	6.3 Block diagram.....	9
	6.4 Power supply.....	9
	6.5 Assembly.....	9
	6.6 FASTCON Pro plugs	10
	6.7 Current measurement.....	10
	6.8 Marking.....	10
7	Configuration	11
8	Status indicator.....	12

3 Ordering data

Description	Type	Order No.	Pcs./Pkt.
Output loop-powered 2-way isolator with plug-in connection technology for the electrical isolation of unipolar and bipolar analog signals. Input configurable via DIP switch. Screw connection technology, standard configuration.	MINI MCR-2-UI-I-OLP	2902061	1
Output loop-powered 2-way isolator with plug-in connection technology for the electrical isolation of unipolar and bipolar analog signals. Input configurable via DIP switch. Push-in connection technology, standard configuration.	MINI MCR-2-UI-I-OLP-PT	2902063	1
Output loop-powered 2-way isolator with plug-in connection technology for the electrical isolation of unipolar and bipolar analog signals. Input configurable via DIP switch. Screw connection technology, order configuration.	MINI MCR-2-UI-I-OLP-C	2902060	1
Output loop-powered 2-way isolator with plug-in connection technology for the electrical isolation of unipolar and bipolar analog signals. Input configurable via DIP switch. Push-in connection technology, order configuration.	MINI MCR-2-UI-I-OLP-PT-C	2902062	1
Accessories	Type	Order No.	Pcs./Pkt.
Marker for end clamp, Sheet, white, unlabeled, can be labeled with: THERMOMARK CARD, BLUEMARK CLED, BLUEMARK LED, TOPMARK LASER, Mounting type: snapped into marker carrier, Lettering field: 30 x 5 mm	UCT-EM (30X5)	0801505	10
Marker for end clamp, can be ordered: by sheet, white, labeled according to customer specifications, Mounting type: snapped into marker carrier, Lettering field: 30 x 5 mm	UCT-EM (30X5) CUS	0801589	1
Marker for end clamp, Sheet, yellow, unlabeled, can be labeled with: THERMOMARK CARD, BLUEMARK CLED, BLUEMARK LED, TOPMARK LASER, Mounting type: snapped into marker carrier, Lettering field: 30 x 5 mm	UCT-EM (30X5) YE	0830340	10
Marker for end clamp, can be ordered: by sheet, yellow, labeled according to customer specifications, Mounting type: snapped into marker carrier, Lettering field: 30 x 5 mm	UCT-EM (30X5) YE CUS	0830348	1
Plastic label, Sheet, white, unlabeled, can be labeled with: BLUEMARK CLED, BLUEMARK LED, Plotter, Mounting type: Adhesive, Lettering field: 15 x 5 mm	UC-EMLP (15X5)	0819301	10
Plastic label, Sheet, white, unlabeled, can be labeled with: BLUEMARK CLED, BLUEMARK LED, Plotter, Mounting type: Adhesive, Lettering field: 15 x 5 mm	UC-EMLP (15X5)L	0820138	5
Plastic label, Sheet, yellow, unlabeled, can be labeled with: BLUEMARK CLED, BLUEMARK LED, Plotter, Mounting type: Adhesive, Lettering field: 15 x 5 mm	UC-EMLP (15X5) YE	0822615	10
Plastic label, can be ordered: by sheet, white, labeled according to customer specifications, Mounting type: Adhesive, Lettering field: 15 x 5 mm	UC-EMLP (15X5) CUS	0824550	1
Plastic label, can be ordered: by sheet, yellow, labeled according to customer specifications, Mounting type: Adhesive, Lettering field: 15 x 5 mm	UC-EMLP (15X5) YE CUS	0824551	1
Plastic label, can be ordered: by sheet, white, labeled according to customer specifications, Mounting type: Adhesive, Lettering field: 15 x 5 mm	UC-EMLP (15X5)L CUS	0824552	1
Plastic label, Sheet, yellow, unlabeled, can be labeled with: BLUEMARK CLED, BLUEMARK LED, Plotter, Mounting type: Adhesive, Lettering field: 15 x 5 mm	UC-EMLP (15X5)L YE	0825325	5
Plastic label, can be ordered: by sheet, yellow, labeled according to customer specifications, Mounting type: Adhesive, Lettering field: 15 x 5 mm	UC-EMLP (15X5)L YE CUS	0826680	1

Accessories	Type	Order No.	Pcs./Pkt.
Plastic label, Sheet, silver, unlabeled, can be labeled with: BLUEMARK CLED, BLUEMARK LED, Plotter, Mounting type: Adhesive, Lettering field: 15 x 5 mm	UC-EMLP (15X5) SR	0828095	10
Plastic label, can be ordered: by sheet, silver, labeled according to customer specifications, Mounting type: Adhesive, Lettering field: 15 x 5 mm	UC-EMLP (15X5) SR CUS	0828099	1
Plastic label, Sheet, silver, unlabeled, can be labeled with: BLUEMARK CLED, BLUEMARK LED, Plotter, Mounting type: Adhesive, Lettering field: 15 x 5 mm	UC-EMLP (15X5)L SR	0828103	5
Marker strip, Roll, white, unlabeled, can be labeled with: THERMOMARK ROLL, THERMOMARK X, THERMOMARK S1.1, THERMOMARK ROLL X1, Mounting type: Adhesive, Lettering field: continuous x 5 mm	SK 5,0 WH:REEL	0805221	1

4 Technical data

Input

Configurable/programmable

Yes

Voltage input signal

0 mV ... 1000 mV
 0 mV ... 750 mV
 0 mV ... 500 mV
 0 mV ... 300 mV
 0 mV ... 250 mV
 0 mV ... 200 mV
 0 mV ... 125 mV
 0 mV ... 120 mV
 0 mV ... 150 mV
 0 mV ... 100 mV
 0 mV ... 75 mV
 0 mV ... 60 mV
 0 mV ... 50 mV
 0 V ... 10 V
 0 V ... 7.5 V
 0 V ... 5 V
 0 V ... 3 V
 0 V ... 2.5 V
 0 V ... 2 V
 0 V ... 1.5 V
 0 V ... 1.25 V
 0 V ... 1.2 V
 0 V ... 30 V
 0 V ... 25 V
 0 V ... 20 V
 0 V ... 12.5 V
 0 V ... 12 V
 0 V ... 15 V
 -1000 mV ... 1000 mV
 -750 mV ... 750 mV
 -500 mV ... 500 mV
 -300 mV ... 300 mV
 -250 mV ... 250 mV
 -200 mV ... 200 mV
 -125 mV ... 125 mV
 -120 mV ... 120 mV
 -150 mV ... 150 mV
 -100 mV ... 100 mV
 -75 mV ... 75 mV
 -60 mV ... 60 mV
 -50 mV ... 50 mV
 -10 V ... 10 V
 -7.5 V ... 7.5 V
 -5 V ... 5 V
 -3 V ... 3 V
 -2.5 V ... 2.5 V
 -2 V ... 2 V
 -1.25 V ... 1.25 V
 -1.2 V ... 1.2 V
 -1.5 V ... 1.5 V
 -30 V ... 30 V
 -25 V ... 25 V
 -20 V ... 20 V
 -12.5 V ... 12.5 V
 -12 V ... 12 V
 1 V ... 5 V
 1 V ... 5 V

Max. voltage input signal

< 30 V

Input	
Current input signal	0 mA ... 0.04 A 0 mA ... 0.03 A 0 mA ... 0.02 A 0 mA ... 0.012 A 0 mA ... 0.01 A 0 mA ... 0.008 A 0 mA ... 0.0075 A 0 mA ... 0.005 A 0 mA ... 0.006 A 0 mA ... 0.004 A 0 mA ... 0.003 A 0 mA ... 0.0025 A 0 mA ... 0.002 A 4 mA ... 0.02 A 2 mA ... 0.01 A 1 mA ... 0.005 A
Max. current input signal	< 40 mA (Dielectric strength up to 30 V)
Input resistance of voltage input	approx. 100 k Ω (At \leq 1 V, otherwise approximately 1 M Ω)
Input resistance current input	\leq 50 Ω
Output	
Current output signal	4 mA ... 0.02 A
Max. current output signal	29 mA
Ripple	< 20 mV _{PP} (at 600 Ω)
Load/output load current output	(U _B - 8 V) / 22 mA
Supply	
Supply voltage range	8 V DC ... 30 V DC (no separate supply voltage necessary)
Typical current consumption	\leq 20 mA
Power consumption	\leq 600 mW
Diagnostic and status indicators	
Operating voltage display	Green LED
General data	
Limit frequency (3 dB)	approx. 30 Hz
Maximum transmission error	< 0.1 % (of final value)
Temperature coefficient, typical	0.005 %/K
Maximum temperature coefficient	0.01 %/K
Step response (10-90%)	15 ms
Electrical isolation	Reinforced insulation in accordance with IEC 61010-1
Overvoltage category	II
Mounting position	any
Degree of protection	IP20
Degree of pollution	2
Rated insulation voltage	300 V (effective)
Test voltage, input/output/supply	3 kV (50 Hz, 1 min.)
Dimensions W/H/D	6.2 mm / 110.5 mm / 120.5 mm
Type of housing	PBT gray

Connection data	Screw connection	Push-in connection
Solid conductor cross section with ferrule	0.2 mm ² ... 1.5 mm ²	0.14 mm ² ... 2.5 mm ²
Solid conductor cross section without ferrule	0.2 mm ² ... 2.5 mm ²	0.14 mm ² ... 2.5 mm ²
Conductor cross section, flexible	0.2 mm ² ... 1.5 mm ²	0.14 mm ² ... 2.5 mm ²
Conductor cross section AWG	24 ... 12	24 ... 12
Stripping length	10 mm	10 mm

Ambient conditions

Ambient temperature (operation)	-40 °C ... 70 °C
Ambient temperature (storage/transport)	-40 °C ... 85 °C
Permissible humidity (operation)	5 % ... 95 % (non-condensing)

Conformance with EMC Directive 2004/108/EC (valid until 19.04.2016) / 2014/30/EU (valid from 20.04.2016)

Noise immunity according to EN 61000-6-2
When being exposed to interference, there may be minimal deviations.

Noise emission according to EN 61000-6-4

Conformance / approvals

Conformance	CE-compliant
ATEX	⊕ II 3 G Ex nA IIC T4 Gc X
UL, USA / Canada	UL 508 Listed
UL, USA / Canada	Class I, Div. 2, Groups A, B, C, D T5
UL, USA / Canada	Class I, Zone 2, Group IIC T5
Shipbuilding DNV GL 14085-15HH	D, EMC1

5 Safety regulations and installation notes

5.1 Installation notes

- The category 3 device is suitable for installation in potentially explosive area zone 2. It fulfills the requirements of EN 60079-0:2012 and EN 60079-15:2010.
- Installation, operation, and maintenance may only be carried out by qualified electricians. Follow the installation instructions as described. When installing and operating the device, the applicable regulations and safety directives (including national safety directives), as well as generally approved technical regulations, must be observed. The safety data is provided in this package slip and on the certificates (conformity assessment, additional approvals where applicable).
- While the devices are in operation, contact-dangerous voltages may be present on the control elements. For this reason parameterization, conductor connection, and opening of the module lid are allowed only when devices are in a de-energized state unless the connected circuits are exclusively SELV or PELV circuits.
- The device must not be opened or modified. Do not repair the device yourself, replace it with an equivalent device. Repairs may only be carried out by the manufacturer. The manufacturer is not liable for damage resulting from violation.
- The IP20 protection (IEC 60529/EN 60529) of the device is intended for use in a clean and dry environment. The device must not be subject to mechanical strain and/or thermal loads, which exceed the limits described.
- The device is not designed for use in atmospheres with a danger of dust explosions.
- The device complies with the EMC regulations for industrial areas (EMC class A). When using the device in residential areas, it may cause radio interference.
- If the device is not used as described in the documentation, the intended protection can be negatively affected.
- To protect the device against mechanical or electrical damage, install it in a suitable housing with appropriate degree of protection as per IEC 60529.
- Provide a switch/circuit breaker close to the device, which is labeled as the disconnecting device for this device.
- Provide for an overcurrent protection device ($I \leq 4 \text{ A}$) in the installation.
- There is a double isolation of $300 \text{ V}_{\text{eff}}$ between neighboring modules of the same type oriented the same way. The device has a base isolation of $150 \text{ V}_{\text{eff}}$ to other neighboring modules on the side with the DIP switch.
- The voltages present at the input, output and supply are extra-low voltages (ELV). Depending on the application, dangerous voltage ($> 30 \text{ V}$) against ground could occur. For this event, safe electrical isolation from the other connections has been implemented.
- The device must be stopped if it is damaged, has been subjected to an impermissible load, stored incorrectly, or if it malfunctions.
- Only use copper connecting cables providing the permitted temperature range ($60^\circ\text{C}/75^\circ\text{C}$).

5.2 Installation in Zone 2

- Observe the specified conditions for use in potentially explosive areas! Install the device in a suitable approved housing (with a minimum of IP54 protection) that meets the requirements of EN 60079-15. Observe the requirements of EN 60079-14.
- Only devices which are designed for operation in Ex zone 2 and are suitable for the conditions at the installation location may be connected to the circuits in the Ex zone.
- In potentially explosive areas, terminals may only be snapped onto or off the DIN rail connector and wires may only be connected or disconnected when the power is switched off.
- The device must be stopped and immediately removed from the Ex area if it is damaged, was subject to an impermissible load, stored incorrectly or if it malfunctions.

5.3 UL Notes

INDUSTRIAL CONTROL EQUIPMENT FOR HAZARDOUS LOCATIONS 45FP

- 1 Suitable for use in class 1, division 2, groups A, B, C and D hazardous locations, or nonhazardous locations only.
- 2 **WARNING - EXPLOSION HAZARD:** Do not disconnect equipment unless power has been removed or the area is known to be non-hazardous.
- 3 **WARNING - EXPLOSION HAZARD:** Substitution of any components may impair suitability for Class I, Division 2.
- 4 This device is open-type and is required to be installed in an enclosure suitable for the environment and can only be accessed with the use of a tool or key.

6 Installation

6.1 Connection notes



The device contains components that can be damaged or destroyed by electrostatic discharge. When handling the device, observe the necessary safety precautions against electrostatic discharge (ESD) according to EN 61340-5-1 and IEC 61340-5-1.

6.2 Structure

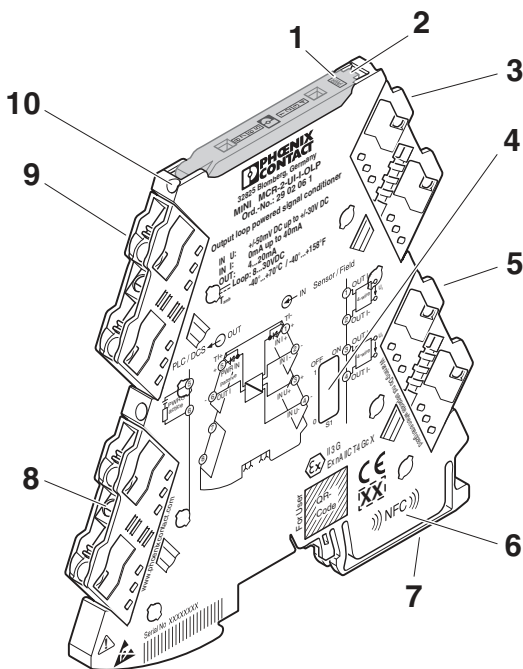

Figure 1 Structure

- 1 Green "PWR" LED, power supply
- 2 Cover with labeling option
- 3 Current input
- 4 DIP switch S1
- 5 Voltage input
- 6 NFC coil
- 7 Universal snap-on foot for EN DIN rails
- 8 Spindle screw
- 9 Current output
- 10 Current measuring socket

6.3 Block diagram

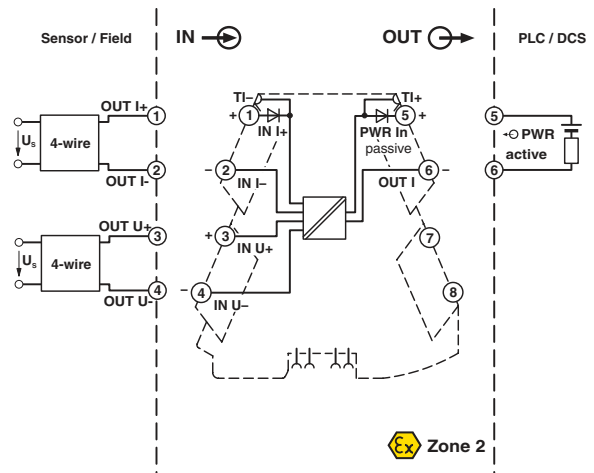

Figure 2 Block diagram

6.4 Power supply

The device is powered via the current loop of the controller.

6.5 Assembly

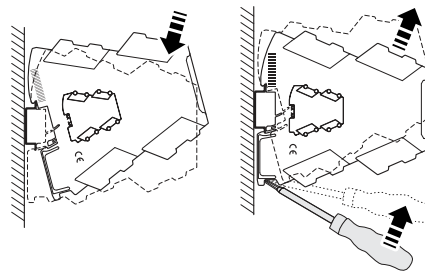

Figure 3 Mounting and removing

- Mount the module on a 35 mm DIN rail according to EN 60715.

An ME 6,2 TBUS-2 DIN rail connector (Order No.: 2869728) is used to supply active devices. A DIN rail connector is not necessary for operation of this loop-powered device.

This device can be snapped onto a DIN rail connector – an electrically conductive connection is not established. This means that you do not need to disconnect an existing DIN rail connector element connection.

6.6 FASTCON Pro plugs

The device has pluggable connection terminals with an integrated test disconnect terminal block, with either push-in or screw-in connection technology.

You can plug or screw the FASTCON Pro plugs onto the device directly without tools. You can use the integrated spindle screw to easily remove the plugs from the module or set the isolating position, even when the plugs are connected. For this purpose, use a screwdriver of sufficient width, e.g. SZF 1-0.6x3.5 (order number: 1204517).

The spindle screw will turn by itself when the FASTCON Pro plugs are connected. There is no need for you to fix the spindle screw in place as well.

4-way coding prevents incorrect insertion into the module.

Screw connection:

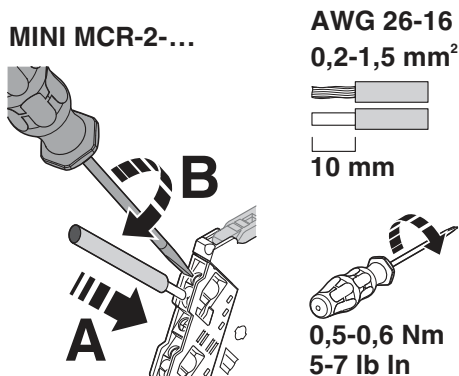

Figure 4 Screw connection

- Insert the wire into the corresponding connection terminal block.
- Use a screwdriver to tighten the screw in the opening above the connection terminal block.

Push-in connection:

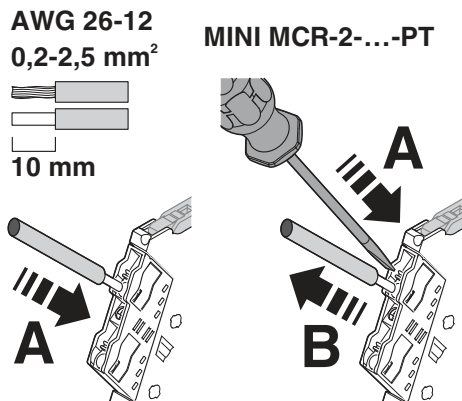

Figure 5 Push-in connection

- Insert the wire into the corresponding connection terminal block.

6.7 Current measurement

The device allows current measurement without disconnection of the conductors by means of integrated test disconnect terminals.

Test sockets which support current measurement are marked T1+ or T1-.

For the current measurement, use 2 mm probe tips of the type Fluke TL75-1 or probe tips with a comparable tip shape.

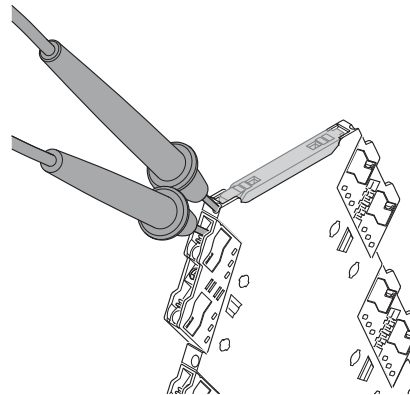

Figure 6 Test disconnect terminal block

Furthermore, individual circuits can be specifically disconnected, e.g. for commissioning.

You can set the isolating position by turning the integrated spindle screw through 180°. The isolating position is indicated by the marking on the plugs.

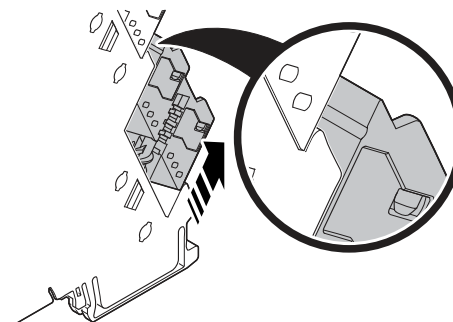

Figure 7 Disconnect position

6.8 Marking

Standard UCT-EM... or UC-EMLP tags are available for marking the devices and can be printed as per customer requirements. In addition, the covers provide enough space for the use of freely chosen sticky labels such as SK 5.0 WH:REEL without concealing the LED diagnostic indicators.

7 Configuration

Standard configuration for devices not configured to order:

Input 2...10 V, output 4...20 mA (all DIP switches in the "off" position; transmission error < 0.1%).

Using DIP switch S1, specify the combination of input and output standard signal ranges.

IN			DIP S1										Terminal		
unipolar	bipolar	• ≙ ON Live zero	1	2	3	4	5	6	7	8	9	0			
0 ... 2 mA					•	•	•	•	•	•			(1)	(2)	
0 ... 2.5 mA					•			•		•			(1)	(2)	
0 ... 3 mA					•				•		•		(1)	(2)	
0 ... 4 mA							•		•	•	•		(1)	(2)	
0 ... 5 mA		1 ... 5 mA						•	•	•			(1)	(2)	
0 ... 6 mA							•						(1)	(2)	
0 ... 7.5 mA								•				•	(1)	(2)	
0 ... 8 mA								•					(1)	(2)	
0 ... 10 mA		2 ... 10 mA							•	•			(1)	(2)	
0 ... 12 mA									•		•		(1)	(2)	
0 ... 20 mA		4 ... 20 mA									•		(1)	(2)	
0 ... 30 mA												•	(1)	(2)	
0 ... 40 mA													(1)	(2)	
0 ... 50 mV	±50 mV		•		•	•			•	•	•		(3)	(4)	
0 ... 60 mV	±60 mV		•		•	•							(3)	(4)	
0 ... 75 mV	±75 mV		•		•				•		•		(3)	(4)	
0 ... 100 mV	±100 mV		•			•			•	•	•		(3)	(4)	
0 ... 120 mV	±120 mV		•						•	•	•		(3)	(4)	
0 ... 125 mV	±125 mV		•						•	•	•		(3)	(4)	
0 ... 150 mV	±150 mV		•			•							(3)	(4)	
0 ... 200 mV	±200 mV		•					•					(3)	(4)	
0 ... 250 mV	±250 mV		•						•	•			(3)	(4)	
0 ... 300 mV	±300 mV		•							•	•		(3)	(4)	
0 ... 500 mV	±500 mV		•								•		(3)	(4)	
0 ... 750 mV	±750 mV		•									•	(3)	(4)	
0 ... 1000 mV	±1000 mV		•										(3)	(4)	
0 ... 1.2 V	±1.2 V							•	•	•	•		(3)	(4)	
0 ... 1.25 V	±1.25 V								•	•	•		(3)	(4)	
0 ... 1.5 V	±1.5 V							•					(3)	(4)	
0 ... 2 V	±2 V								•				(3)	(4)	
0 ... 2.5 V	±2.5 V									•	•		(3)	(4)	
0 ... 3 V	±3 V									•		•	(3)	(4)	
0 ... 5 V	±5 V	1 ... 5 V										•	(3)	(4)	
0 ... 7.5 V	±7.5 V												•	(3)	(4)
0 ... 10 V	±10 V	2 ... 10 V											(3)	(4)	
0 ... 12 V	±12 V			•					•	•	•	•	(3)	(4)	
0 ... 12.5 V	±12.5 V			•					•	•	•	•	(3)	(4)	
0 ... 15 V	±15 V			•		•							(3)	(4)	
0 ... 20 V	±20 V			•				•					(3)	(4)	
0 ... 25 V	±25 V			•					•	•	•		(3)	(4)	
0 ... 30 V	±30 V			•						•	•	•	(3)	(4)	
Signal conversion	IN bipolar /	OUT Live zero (4 ... 20 mA)													
	IN unipolar /	OUT Live zero (4 ... 20 mA)													
	IN Live zero /	OUT Live zero (4 ... 20 mA)													



Additional signal combinations that are not listed in the table are available on request.

8 Status indicator

Green LED	PWR	Supply voltage
	Lit	Supply voltage present