

SN5433, SN54LS33, SN7433, SN74LS33

Quadruple 2-Input Positive-NOR Buffers With Open-Collector Outputs

These devices contain four independent 2-input NOR buffer gates with open-collector outputs. Open-collector outputs require resistive pull-up to perform logically but can deliver higher V_{OH} levels and are commonly used in wired-AND applications.

The SN5433 and SN54LS33 are characterized for operation over the full military temperature range of -55°C to 125°C . The SN7433 and SN74LS33 are characterized for operation from 0°C to 70°C .

Rochester Electronics Manufactured Components

Rochester branded components are manufactured using either die/wafers purchased from the original suppliers or Rochester wafers recreated from the original IP. All recreations are done with the approval of the OCM.

Parts are tested using original factory test programs or Rochester developed test solutions to guarantee product meets or exceeds the OCM data sheet.

Quality Overview

- ISO-9001
- AS9120 certification
- Qualified Manufacturers List (QML) MIL-PRF-38535
 - Class Q Military
 - Class V Space Level
- Qualified Suppliers List of Distributors (QSLD)
 - Rochester is a critical supplier to DLA and meets all industry and DLA standards.

Rochester Electronics, LLC is committed to supplying products that satisfy customer expectations for quality and are equal to those originally supplied by industry manufacturers.

The original manufacturer's datasheet accompanying this document reflects the performance and specifications of the Rochester manufactured version of this device. Rochester Electronics guarantees the performance of its semiconductor products to the original OEM specifications. 'Typical' values are for reference purposes only. Certain minimum or maximum ratings may be based on product characterization, design, simulation, or sample testing.

SN5433, SN54LS33, SN7433, SN74LS33 QUADRUPLE 2-INPUT POSITIVE-NOR BUFFERS WITH OPEN-COLLECTOR OUTPUTS

DECEMBER 1983—REVISED MARCH 1988

- Package Options Include Plastic "Small Outline" Packages, Ceramic Chip Carriers and Flat Packages, and Plastic and Ceramic DIPs
- Dependable Texas Instruments Quality and Reliability

description

These devices contain four independent 2-input NOR buffer gates with open-collector outputs. Open-collector outputs require resistive pull-up to perform logically but can deliver higher V_{OH} levels and are commonly used in wired-AND applications.

The SN5433 and SN54LS33 are characterized for operation over the full military temperature range of -55°C to 125°C . The SN7433, and SN74LS33 are characterized for operation from 0°C to 70°C .

FUNCTION TABLE (each gate)

INPUTS		OUTPUT
A	B	Y
H	X	L
X	H	L
L	L	H

logic symbol†

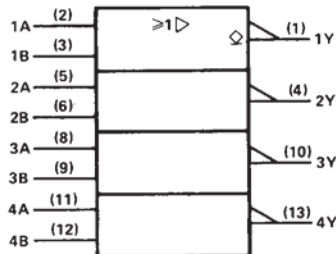

† This symbol is in accordance with ANSI/IEEE Std 91-1984 and IEC Publication 617-12.

Pin numbers shown are for D, J, N, and W packages.

SN5433, SN54LS33 . . . J OR W PACKAGE
SN7433 . . . N PACKAGE
SN74LS33 . . . D OR N PACKAGE
(TOP VIEW)

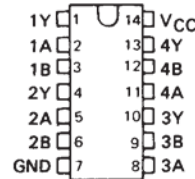

SN54LS33 . . . FK PACKAGE
(TOP VIEW)

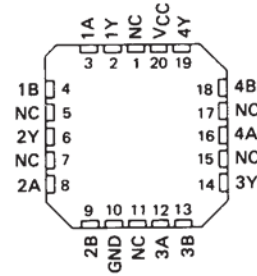

NC - No internal connection

logic diagram

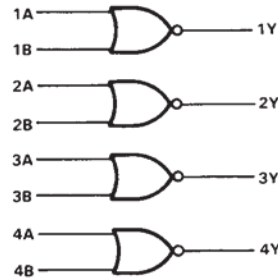

positive logic

$$Y = A + B \text{ or } Y = \overline{A \cdot B}$$

PRODUCTION DATA documents contain information current as of publication date. Products conform to specifications per the terms of Texas Instruments standard warranty. Production processing does not necessarily include testing of all parameters.

TEXAS
INSTRUMENTS

POST OFFICE BOX 655012 • DALLAS, TEXAS 75265

2-143

2

TTL Devices

SN5433, SN54LS33, SN7433, SN74LS33
QUADRUPLE 2-INPUT POSITIVE-NOR BUFFERS WITH OPEN-COLLECTOR OUTPUTS

schematics (each gate)

2 TTL Devices

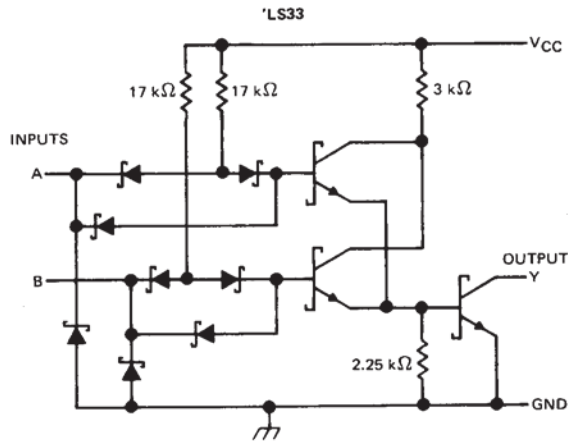
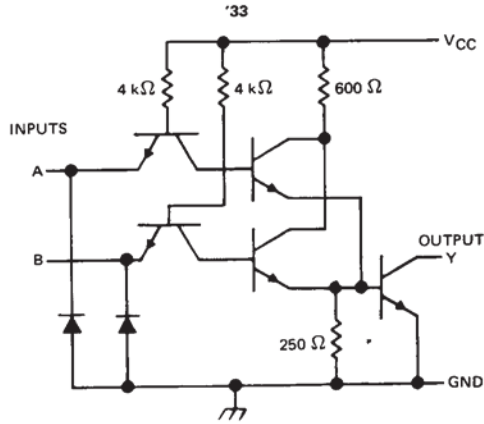

Resistor values shown are nominal.

absolute maximum ratings over operating free-air temperature (unless otherwise noted)

Supply voltage, V_{CC} (see Note 1)	7 V
Input voltage: '33	5.5 V
'LS33	7 V
Off-state output voltage	7 V
Operating free-air temperature: SN54'	-55°C to 125°C
SN74'	0°C to 70°C
Storage temperature range	-65°C to 150°C

NOTE 1: Voltage values are with respect to network ground terminal.

SN5433, SN7433

QUADRUPLE 2-INPUT POSITIVE-NOR BUFFERS WITH OPEN-COLLECTOR OUTPUTS

recommended operating conditions

		SN5433			SN7433			UNIT
		MIN	NOM	MAX	MIN	NOM	MAX	
V _{CC}	Supply voltage	4.5	5	5.5	4.75	5	5.25	V
V _{IH}	High-level input voltage	2			2			V
V _{IL}	Low-level input voltage	0.8			0.8			V
V _{OH}	High-level output voltage	5.5			5.5			V
I _{OL}	Low-level output current	48			48			mA
T _A	Operating free-air temperature	-55	125		0	70		°C

electrical characteristics over recommended operating free-air temperature range (unless otherwise noted)

PARAMETER	TEST CONDITIONS [†]	SN5433			SN7433			UNIT
		MIN	TYP [‡]	MAX	MIN	TYP [‡]	MAX	
V _{IK}	V _{CC} = MIN, I _I = -12 mA	-1.5			-1.5			V
I _{OH}	V _{CC} = MIN, V _{IL} = 0.8 V, V _{OH} = 5.5 V				0.25			mA
	V _{CC} = MIN, V _{IL} = 0.7 V, V _{OH} = 5.5 V	0.25						
V _{OL}	V _{CC} = MIN, V _{IH} = 2 V, I _{OL} = 16 mA	0.2	0.4		0.2	0.4		V
I _I	V _{CC} = MAX, V _I = 5.5 V	1			1			mA
I _{IH}	V _{CC} = MAX, V _I = 2.4 V	40			40			μA
I _{IL}	V _{CC} = MAX, V _I = 0.4 V	-1.6			-1.6			mA
I _{CCCH}	V _{CC} = MAX, V _I = 0	3	6		3	6		mA
I _{CCCL}	V _{CC} = MAX, See Note 2	9	16.5		9	16.5		mA

[†]For conditions shown as MIN or MAX, use the appropriate value specified under recommended operating conditions.

[‡]All typical values are at V_{CC} = 5 V, T_A = 25°C.

NOTE 2: One input at 4.5 V, all others at 0 V.

switching characteristics, V_{CC} = 5 V, T_A = 25°C (see Figure 1)

PARAMETER	FROM (INPUT)	TO (OUTPUT)	TEST CONDITIONS	MIN	TYP	MAX	UNIT
t _{PLH}	A or B	Y	R _L = 133 kΩ, C _L = 50 pF	10	15		ns
t _{PHL}				12	18		ns
t _{PLH}			R _L = 133 kΩ, C _L = 150 pF	15	22		ns
t _{PHL}				16	24		ns

NOTE 3: Load circuits and voltage waveforms are shown in Section 1.

2
TTL Devices

SN54LS33, SN74LS33 QUADRUPLE 2-INPUT POSITIVE-NOR BUFFERS WITH OPEN-COLLECTOR OUTPUTS

recommended operating conditions

	SN54LS33			SN74LS33			UNIT
	MIN	NOM	MAX	MIN	NOM	MAX	
V _{CC} Supply voltage	4.5	5	5.5	4.75	5	5.25	V
V _{IH} High-level input voltage	2			2			V
V _{IL} Low-level input voltage			0.7			0.8	V
V _{OH} High-level output voltage			5.5			5.5	V
I _{OL} Low-level output current			12			24	mA
T _A Operating free-air temperature	-55		125	0		70	°C

electrical characteristics over recommended operating free-air temperature range (unless otherwise noted)

PARAMETER	TEST CONDITIONS †	SN54LS33			SN74LS33			UNIT
		MIN	TYP ‡	MAX	MIN	TYP ‡	MAX	
V _{IK}	V _{CC} = MIN, I _I = -18 mA		-1.5			-1.5	V	
I _{OH}	V _{CC} = MIN, V _{IH} = 2 V, V _{IL} = MAX, V _{OH} = 5.5 V			0.25		0.25	mA	
V _{OL}	V _{CC} = MIN, V _{IH} = 2 V, V _{IL} = MAX, I _{OL} = 12 mA		0.25	0.4		0.25	0.4	
	V _{CC} = MIN, V _{IL} = MAX, I _{OL} = 24 mA					0.35	0.5	
I _I	V _{CC} = MAX, V _I = 7 V			0.1		0.1	mA	
I _{IH}	V _{CC} = MAX, V _I = 2.7 V			20		20	μA	
I _{IL}	V _{CC} = MAX, V _I = 0.4 V			-0.4		-0.4	mA	
I _{CCH}	V _{CC} = MAX, V _I = 0		1.8	3.6		1.8	3.6	
I _{CCL}	V _{CC} = MAX, See Note 2		6.9	13.8		6.9	13.8	

† For conditions shown as MIN or MAX, use the appropriate value specified under recommended operating conditions.

‡ All typical values are at V_{CC} = 5 V, T_A = 25°C.

NOTE 2: One input at 4.5 V, all others at 0 V.

switching characteristics, V_{CC} = 5 V, T_A = 25°C (see note 3)

PARAMETER	FROM (INPUT)	TO (OUTPUT)	TEST CONDITIONS	MIN	TYP	MAX	UNIT
t _{PLH}	A or B	Y	R _L = 667 Ω, C _L = 45 pF		20	32	ns
t _{PHL}					18	28	ns

NOTE 3: Load circuits and voltage waveforms are shown in Section 1.

2

TTL Devices