

NL3S325

Audio Jack GND/MIC Configuration Switch

The NL3S325 is an audio jack configuration switch device. It allows reconfiguration of the GND, microphone-bias contact to comply with the American Headset Jack (AHJ) and the Open Mobile Terminal Platform (OMTP) pinout. It also provides a GND sense path that supports quasi-differential audio amplifier architectures.

Features

- AHJ and OMTP Headset Jack Pinout Support
- Wide V_{DD} Range: 1.6 V to 3.7 V
- Low Supply Current
- Sense Path to GND for Quasi Differential Audio Amplifier Configuration
- Low THD and Noise Microphone Pass-through Channel
- Ultra-low R_{ON} of Ground and Sense Switches
- High Power Supply Ripple Rejection
- ESD Performance:
 - 8 kV HBM on SBU_n, SENSE_n, SENSE, V_{DD} , GND
 - 3 kV HBM on MIC, SEL
- Available in 1.19 mm x 1.19 mm WLCSP9
- This Device is Pb-Free, Halogen Free/BFR Free and RoHS Compliant

Applications

- Headsets with Integrated MIC and Remote Control Buttons
- USB Type-C Switching



ON Semiconductor®

www.onsemi.com



**WLCSP9
FC SUFFIX
CASE 567MD**

MARKING DIAGRAM

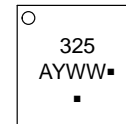

325 = Specific Device Code
A = Assembly Location
Y = Year
WW = Work Week
▪ = Pb-Free Package

(Note: Microdot may be in either location)

ORDERING INFORMATION

Device	Package	Shipping†
NL3S325FCT2G	WLCSP9 (Pb-Free)	3000 / Tape & Reel

†For information on tape and reel specifications, including part orientation and tape sizes, please refer to our Tape and Reel Packaging Specifications Brochure, BRD8011/D.

NL3S325

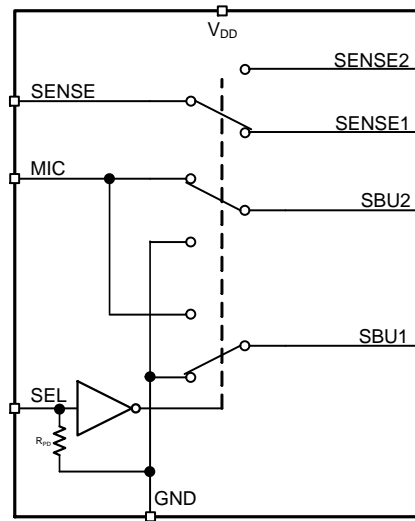

Figure 1. Block Diagram

Table 1. FUNCTION TABLE

V _{DD}	SEL	Connections	Mode
0 V	X	All I/O Ports Hi-Z	Disabled
1.6 V to 3.6 V	0	SBU2=MIC; SBU1=GND; SENSE1=SENSE	AHJ
1.6 V to 3.6 V	1	SBU1=MIC; SBU2=GND; SENSE2=SENSE	OMTP

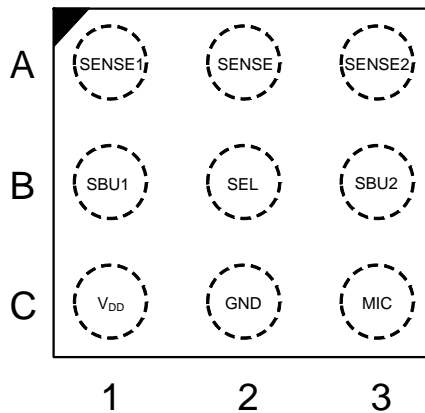
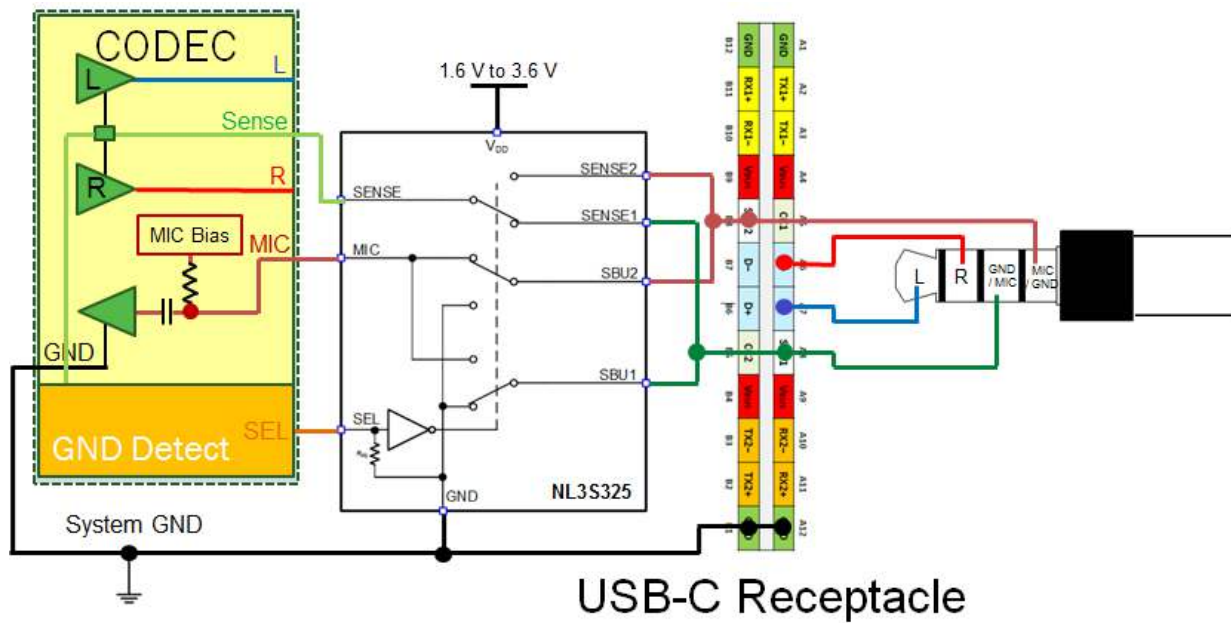

Figure 2. WLCSP9 – Top Through View

Table 2. PIN DESCRIPTIONS

Pin Name	Ball	Description
SENSE1	A1	Sense Path 1 to Headset Jack GND
SENSE	A2	Sense Path for GND Sensing
SENSE2	A3	Sense Path 2 to Headset Jack GND
SBU1	B1	USB Type-C SBU1 Connection
SEL	B2	Configuration Select
SBU2	B3	USB Type-C SBU2 Connection
V _{DD}	C1	Power Supply
GND	C2	Ground
MIC	C3	MIC Bias Path CODEC Side

NL3S325



The default configuration (SEL = 0) is for AHJ-compliant headsets.

Figure 3. Typical Application

NOTE: When V_{DD} is not powered, all the FETs become open by default. Thus, the ground return path becomes floating. Noise might be heard if a speaker (with external powered amplifier) is plugged in the audio jack. It is highly recommended when the audio jack detects a plug-in, the NL3S325 is kept powered until unplug.

Table 3. MAXIMUM RATINGS

Symbol	Rating	Value	Unit		
V_{DD}	Positive DC Supply Voltage	-0.5 to +4.5	V		
V_{IS}	Analog Input/Output Voltage	-0.5 to +4.5	V		
V_{IN}	Digital Control Pin Voltage, SEL	-0.5 to +4.5	V		
$I_{SW(GND)}$	Continuous SBU1 or SBU2 to GND Current	100	mA		
$I_{SW(MIC)}$	Continuous MIC to SBU1 or SBU2 Current	50	mA		
$I_{SW(SNS)}$	Continuous SENSE to SENSE1 or SENSE2 Current	50	mA		
T_s	Storage Temperature	-55 to +150	°C		
T_L	Lead Temperature, 1 mm from Case for 10 seconds	260	°C		
T_J	Junction Temperature Under Bias	150	°C		
MSL	Moisture Sensitivity (Note 1)	Level 1			
I_{LU}	Latchup Current (Note 2)	±100	mA		
ESD	ESD Protection (Note 3)	Human Body Model	SENSE, SENSEn, SBU1, V_{DD} , GND	8000	V
			MIC, SEL	3000	
		Machine Model	All Pins	200	
		Charged Device Model	All Pins	1000	

Stresses exceeding those listed in the Maximum Ratings table may damage the device. If any of these limits are exceeded, device functionality should not be assumed, damage may occur and reliability may be affected.

1. Moisture Sensitivity Level (MSL): 1 per IPC/JEDEC standard: J-STD-020A.
2. Latch up Current Maximum Rating: ±100 mA per JEDEC standard: JESD78.
3. This device series contains ESD protection and passes the following tests:
 Human Body Model (HBM) per JEDEC standard: JESD22-A114.
 Machine Model (MM) per JEDEC standard: JESD22-A115.

NL3S325

Table 4. RECOMMENDED OPERATING CONDITIONS

Symbol	Parameter	Min	Max	Unit
V _{DD}	Positive DC Supply Voltage	1.6	3.7	V
V _{IS}	Switch Input / Output Voltage	GND	3.6	V
V _{IN}	Digital Control Input Voltage	GND	3.6	V
T _A	Operating Temperature Range	-40	+85	°C

Functional operation above the stresses listed in the Recommended Operating Ranges is not implied. Extended exposure to stresses beyond the Recommended Operating Ranges limits may affect device reliability.

Table 5. DC ELECTRICAL CHARACTERISTICS (Typical values are at V_{DD} = +3.0 V and T_A = +25°C unless otherwise specified.)

Symbol	Parameter	Test Conditions	V _{DD} (V)	-40°C to 85°C			Unit
				Min	Typ	Max	
POWER SUPPLY							
I _{DD}	Supply Current	T _A = 25°C	3.0	-	0.1	1	μA
		T _A = 85°C	3.0	-	-	5	
CONTROL LOGIC (SEL)							
V _{IH}	Input High Voltage		3.0	1.0	-	-	V
V _{IL}	Input Low Voltage		3.0	-	-	0.4	V
R _{PD}	Pull-down Resistor		1.6 – 3.6	-	550	-	kΩ
I _{OFF}	Power OFF Leakage	V _{IN} = 3.6 V	0	-	-	1	μA
MIC BIAS SWITCH (MIC to SBU1 or SBU2)							
R _{ON}	ON-Resistance	V _{IS} = 850 mV, I _O = 30 mA	1.8	-	1.6	2.0	Ω
			3.0	-	0.5	0.9	Ω
			3.6	-	0.46	0.8	Ω
R _{ON(FLAT)}	ON-Resistance Flatness	V _{IS} = 0.8 V to 1.2 V, I _O = 30 mA	1.8	-	-	0.6	Ω
			3.0	-	-	0.2	Ω
			3.6	-	-	0.1	Ω
I _S	Switch Leakage Current	V _{MIC} = 850 mV, SBU _n Open, SEL = H or L	1.6 to 3.6	-	-	1.5	μA
C _S	Switch Capacitance	MIC, SBU _n Open, SEL = H or L	3.0	-	250	-	pF
THD	Total Harmonic Distortion of Conducting Switch	R _S = R _L = 600 Ω, f _{AC} = 20 kHz, V _{AC} = 0.5 V _{PP} , V _{DC} = 1.7 V, SEL = H or L	3.0	-	0.002	-	%
PSRR	Power Supply Rejection Ratio of Conducting Switch	R _S = R _L = 600 Ω, f = 217 Hz, V _{AC} = 0.3 V _{PP} , V _{DC} = 2.1 V, SEL = H or L	3.0	-	-103	-	dB
GND SWITCH (SBU1 or SBU2 to GND)							
R _{ON}	ON-Resistance	I _{ISBU_n} = 100 mA	1.8	-	70	130	mΩ
			3.0	-	60	110	mΩ
			3.6	-	57	105	mΩ
R _{ON(FLAT)}	ON-Resistance	I _{ISBU_n} = 10 mA	1.8 to 3.6	-	-	50	mΩ
	Flatness	I _{ISBU_n} = 1 mA	1.8 to 3.6	-	-	30	mΩ
PSRR	Power Supply Rejection Ratio of Conducting Switch	R _S = 8 Ω, V _S = 1 V, f = 217 Hz, V _{AC} = 0.3 V _{PP} , SEL = H or L	3.0	-	-88	-	dB

NL3S325

Table 5. DC ELECTRICAL CHARACTERISTICS (Typical values are at $V_{DD} = +3.0\text{ V}$ and $T_A = +25^\circ\text{C}$ unless otherwise specified.)

Symbol	Parameter	Test Conditions	V_{DD} (V)	-40°C to 85°C			Unit
				Min	Typ	Max	
SENSE SWITCH (SENSE to SENSE1 or SENSE2)							
R_{ON}	ON-Resistance	$I_{SENSE} = 30\text{ mA}$, $SENSE_n = 0\text{ V}$	1.8	–	80	130	$m\Omega$
			3.0	–	60	90	
			3.6	–	57	82	
$R_{ON(FLAT)}$	ON-Resistance	$I_{SENSE} = 10\text{ mA}$, $SENSE_n = 0\text{ V}$	1.8 to 3.6	–	–	50	$m\Omega$
	Flatness	$I_{SENSE} = 1\text{ mA}$, $SENSE_n = 0\text{ V}$	1.8 to 3.6	–	–	40	
I_S	Switch Leakage Current	$V_{SENSE} = 1\text{ V}$, $SEL = L$, $SENSE1$ Open, $SENSE2 = GND$	1.6 to 3.6	–	–	1	μA
		$V_{SENSE} = 1\text{ V}$, $SEL = H$, $SENSE1 = GND$, $SENSE2$ Open		–	–	1	

Product parametric performance is indicated in the Electrical Characteristics for the listed test conditions, unless otherwise noted. Product performance may not be indicated by the Electrical Characteristics if operated under different conditions.

Test Circuit and Graphs

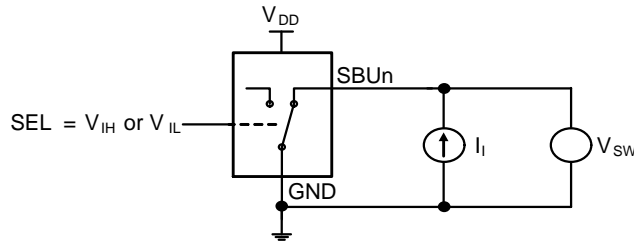

Figure 4. ON Resistance

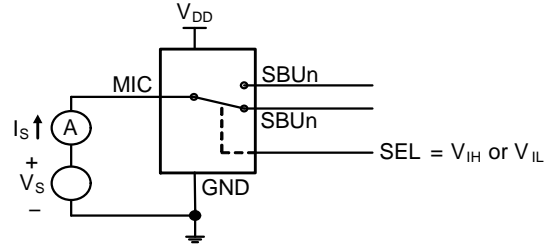

Figure 5. Leakage Current

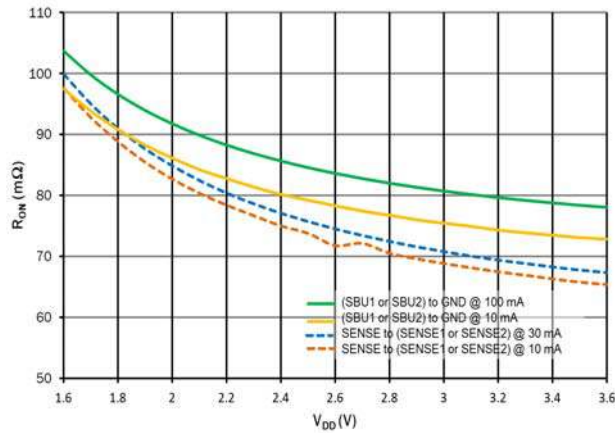

Figure 6. R_{ON} (GND/SENSE @ $I_I = 1\text{ mA}$)

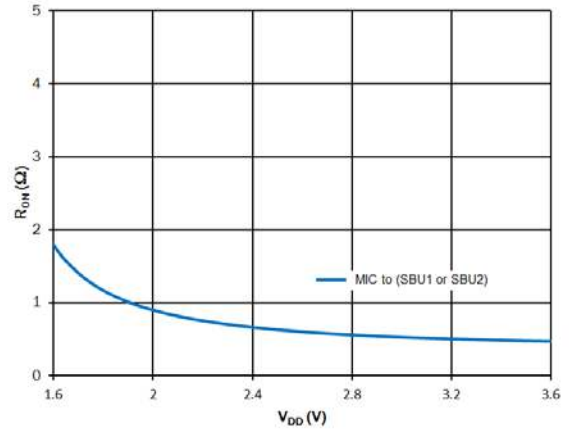

Figure 7. R_{ON} (MIC @ $I_I = 30\text{ mA}$)

NL3S325

Table 6. AC ELECTRICAL CHARACTERISTICS (Typical values are at $V_{DD} = +3.0\text{ V}$ and $T_A = +25^\circ\text{C}$, unless otherwise specified.)

Symbol	Parameter	Test Conditions	V_{CC} (V)	-40°C to 85°C			Unit
				Min	Typ	Max	
t_{ON}	Turn-On Time	$V_{MIC} = V_{DD}$, $V_{SENSE} = 0\text{ V}$, $R_L = 50\ \Omega$, $C_L = 35\text{ pF}$	3.0	-	215	400	ns
t_{OFF}	Turn-Off Time	$V_{MIC} = V_{DD}$, $V_{SENSE} = 0\text{ V}$, $R_L = 50\ \Omega$, $C_L = 35\text{ pF}$	3.0	-	80	140	ns
t_{BBM}	Break-before-make Time	$V_{MIC} = V_{DD}$, $V_{SENSE} = 0\text{ V}$, $R_L = 50\ \Omega$, $C_L = 35\text{ pF}$	3.0	70 (Note 4)	100	320	ns

4. Guaranteed by design.

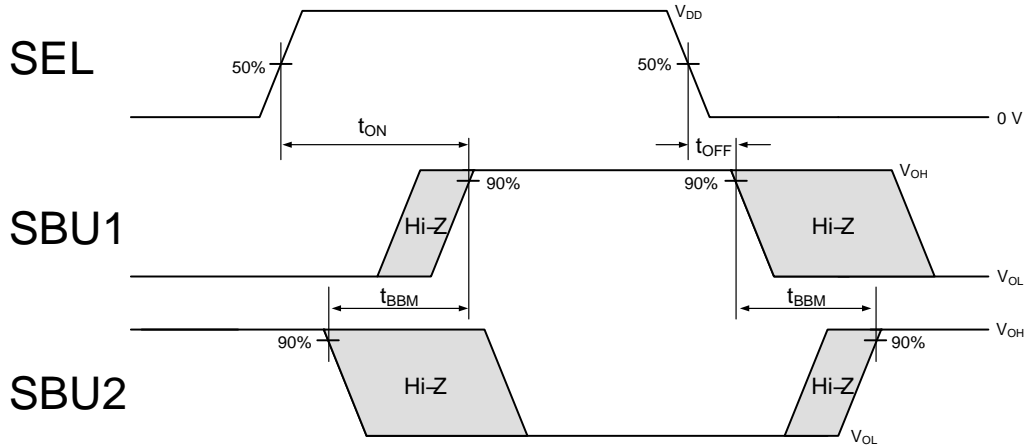
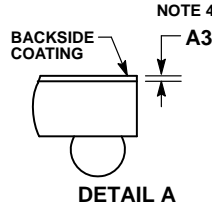
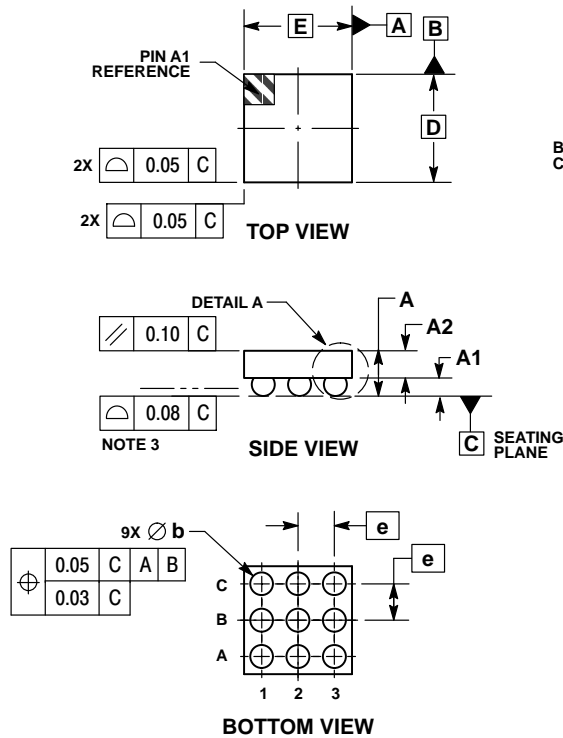

Figure 8. t_{ON} , t_{OFF} , t_{BBM} Waveform

NL3S325

PACKAGE DIMENSIONS

WLCSP9, 1.19x1.19 CASE 567MD ISSUE A



NOTES:

1. DIMENSIONING AND TOLERANCING PER ASME Y14.5M, 1994.
2. CONTROLLING DIMENSION: MILLIMETERS.
3. COPLANARITY APPLIES TO THE SPHERICAL CROWNS OF THE SOLDER BALLS.
4. BACKSIDE COATING IS OPTIONAL.

DIM	MILLIMETERS	
	MIN	MAX
A	—	0.52
A1	0.18	0.22
A2	0.26	0.29
A3	0.000	0.027
b	0.24	0.28
D	1.19 BSC	
E	1.19 BSC	
e	0.40 BSC	

RECOMMENDED SOLDERING FOOTPRINT*

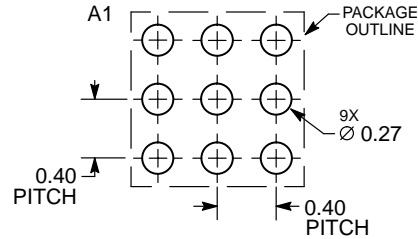

DIMENSIONS: MILLIMETERS

*For additional information on our Pb-Free strategy and soldering details, please download the ON Semiconductor Soldering and Mounting Techniques Reference Manual, SOLDERRM/D.

ON Semiconductor and are trademarks of Semiconductor Components Industries, LLC dba ON Semiconductor or its subsidiaries in the United States and/or other countries. ON Semiconductor owns the rights to a number of patents, trademarks, copyrights, trade secrets, and other intellectual property. A listing of ON Semiconductor's product/patent coverage may be accessed at www.onsemi.com/site/pdf/Patent-Marking.pdf. ON Semiconductor reserves the right to make changes without further notice to any products herein. ON Semiconductor makes no warranty, representation or guarantee regarding the suitability of its products for any particular purpose, nor does ON Semiconductor assume any liability arising out of the application or use of any product or circuit, and specifically disclaims any and all liability, including without limitation special, consequential or incidental damages. Buyer is responsible for its products and applications using ON Semiconductor products, including compliance with all laws, regulations and safety requirements or standards, regardless of any support or applications information provided by ON Semiconductor. "Typical" parameters which may be provided in ON Semiconductor data sheets and/or specifications can and do vary in different applications and actual performance may vary over time. All operating parameters, including "Typicals" must be validated for each customer application by customer's technical experts. ON Semiconductor does not convey any license under its patent rights nor the rights of others. ON Semiconductor products are not designed, intended, or authorized for use as a critical component in life support systems or any FDA Class 3 medical devices or medical devices with a same or similar classification in a foreign jurisdiction or any devices intended for implantation in the human body. Should Buyer purchase or use ON Semiconductor products for any such unintended or unauthorized application, Buyer shall indemnify and hold ON Semiconductor and its officers, employees, subsidiaries, affiliates, and distributors harmless against all claims, costs, damages, and expenses, and reasonable attorney fees arising out of, directly or indirectly, any claim of personal injury or death associated with such unintended or unauthorized use, even if such claim alleges that ON Semiconductor was negligent regarding the design or manufacture of the part. ON Semiconductor is an Equal Opportunity/Affirmative Action Employer. This literature is subject to all applicable copyright laws and is not for resale in any manner.

PUBLICATION ORDERING INFORMATION

LITERATURE FULFILLMENT:

Literature Distribution Center for ON Semiconductor
19521 E. 32nd Pkwy, Aurora, Colorado 80011 USA
Phone: 303-675-2175 or 800-344-3860 Toll Free USA/Canada
Fax: 303-675-2176 or 800-344-3867 Toll Free USA/Canada
Email: orderlit@onsemi.com

N. American Technical Support: 800-282-9855 Toll Free
USA/Canada
Europe, Middle East and Africa Technical Support:
Phone: 421 33 790 2910

ON Semiconductor Website: www.onsemi.com

Order Literature: <http://www.onsemi.com/orderlit>

For additional information, please contact your local Sales Representative