

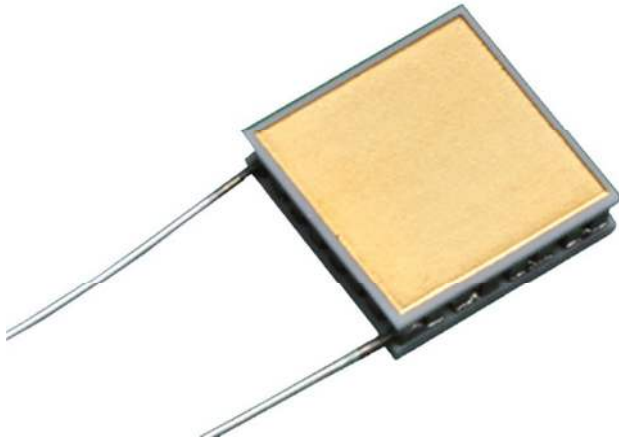

# Technical Data Sheet for NL1020T

## Single-Stage Thermoelectric Module



### NOMINAL PERFORMANCE IN NITROGEN

Hot Side Temperature (°C)	27	50
$\Delta T_{max}$ (°C):	64	72
Q <sub>max</sub> (watts):	0.9	1.0
I <sub>max</sub> (amps):	1.8	1.8
V <sub>max</sub> (vdc):	0.8	0.9
AC Resistance (ohms):	0.40	--

### PRODUCT FEATURES

- RoHS EU Compliant
- REACH EU Compliant
- Rated operating temperature of 85°C.
- Maximum process temperature is 120°C.
- Ceramic Material: Aluminum Oxide
- -01AC, -02AC: External Metallization is Au flash, suitable for soldering.
- RTV sealing option available.

### ORDERING OPTIONS

Model Number	Description
NL1020T-01AC	Both surfaces are metallized
NL1020T-02AC	Hot side exterior is metallized
NL1020T-03AC	No metallization
NL1020T-04AC	No metallization, Insulated Leads, Perimeter Sealed
NL1020T-05AC	No metallization, Insulated Leads

### OPERATION CAUTIONS

For maximum reliability, storage and operation below 85°C in a non-condensing environment is recommended. To minimize thermal stress, use linear/proportional temperature control or a similar method rather than an ON/OFF method.

### INSTALLATION

Recommended mounting methods: Bonding with thermal epoxy or soldering with metallized ceramics. For additional information, please refer to our TEC Installation Guide.

II-VI Marlow – Dallas, TX USA  
214-340-4900  
877-627-5691  
marlow.sales@ii-vi.com

Marlow Industries Europe  
GmbH - Germany  
+49 (0) 6150 5439 - 403  
info@marlow-europe.eu

II-VI Japan Inc.  
81 43 297 2693 (tel)  
center@ii-vi.co.jp  
www.ii-vi.co.jp

II-VI Singapore Pte., Ltd.  
(65) 6481 8215 (tel)  
info@ii-vi.com.sg

Marlow Industries China, II-VI  
Technologies Beijing  
86-10-643 98226  
info@iivibj.com



**TYPICAL PERFORMANCE CURVES**

**ENVIRONMENT: ONE ATMOSPHERE DRY NITROGEN**

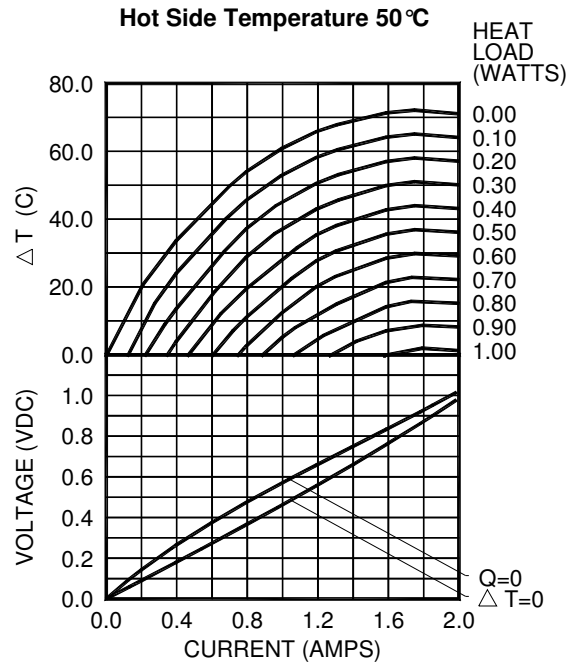
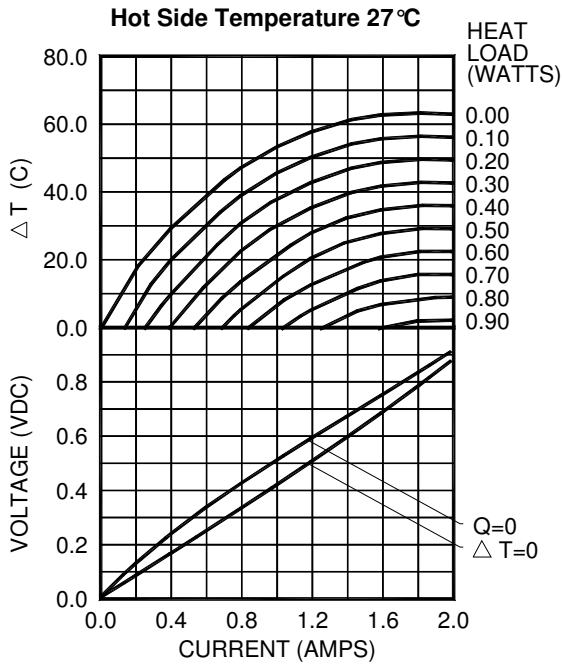

For performance information in a vacuum or with hot side temperatures other than 27°C or 50°C, contact one of our Applications Engineers at 877-627-5691.

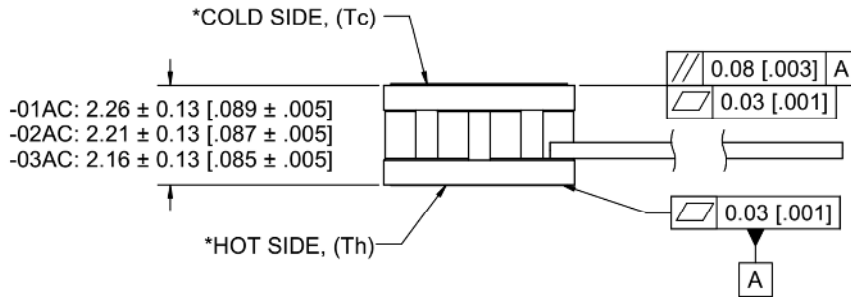
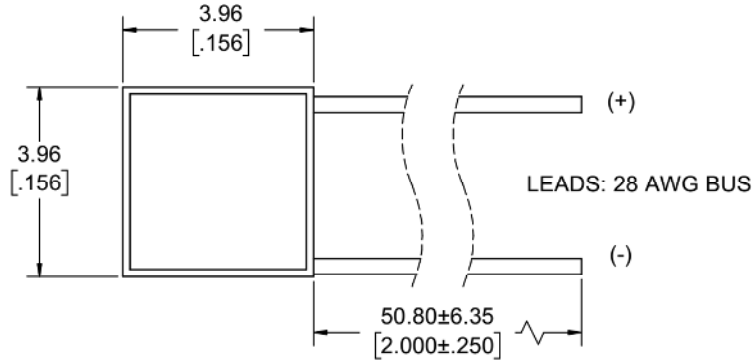

Dimensions are in millimeters, inches are in [ ].

\* -01AC, -02AC Only: External Metallization per page 1.

**-01AC, -02AC, -03AC**

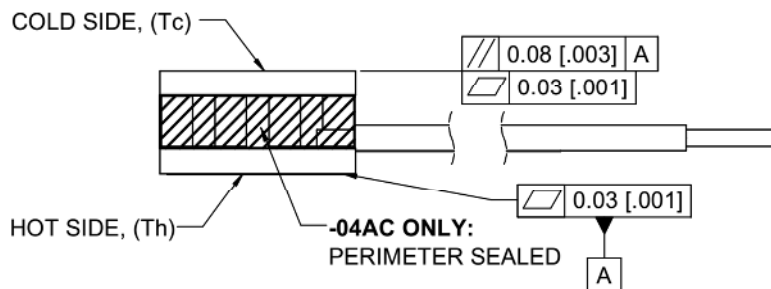
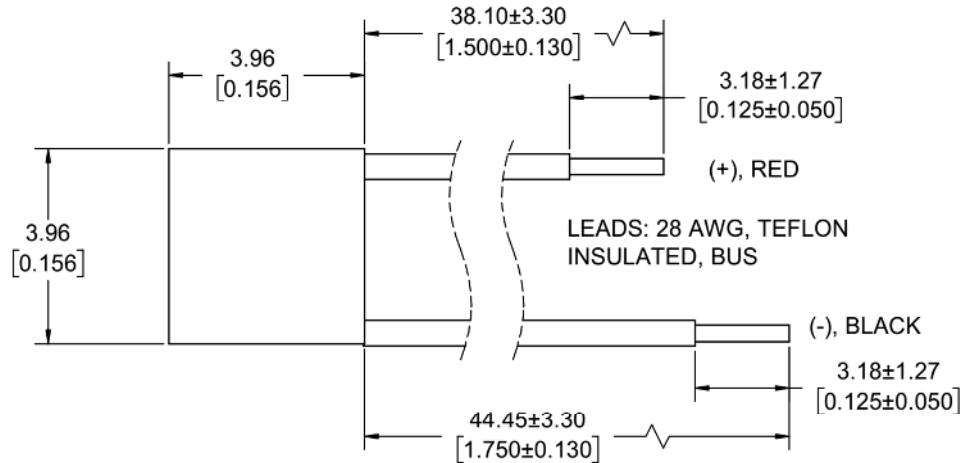

Dimensions are in millimeters, and inches are in [ ].

**-04AC, -05AC**

For customer support or general questions please contact a local office or visit our website at [www.marlow.com](http://www.marlow.com).  
Marlow reserves the right to make product changes without notice.