

# IrDA2™

## Manual

*All Mikroelektronika's development systems feature a large number of peripheral modules expanding microcontroller's range of application and making the process of program testing easier. In addition to these modules, it is also possible to use numerous additional modules linked to the development system through the I/O port connectors. Some of these additional modules can operate as stand-alone devices without being connected to the microcontroller.*

# Additional Board

 **MikroElektronika**

SOFTWARE AND HARDWARE SOLUTIONS FOR EMBEDDED WORLD ...making it simple

## IrDA2 Additional Board

The *IrDA2* additional board is used for wireless communication carried out via infrared waves. This board includes an infrared transceiver modul TFDU4101 used for serial communication with devices transferring data via infrared waves such as printers, fax machines, notebooks, industrial devices, etc. The MCP2120 circuit provided on the board is used to convert data received from the transceiver module and send it to the microcontroller for further processing. The *IrDA2* board communicates with a microcontroller via serial communication UART.

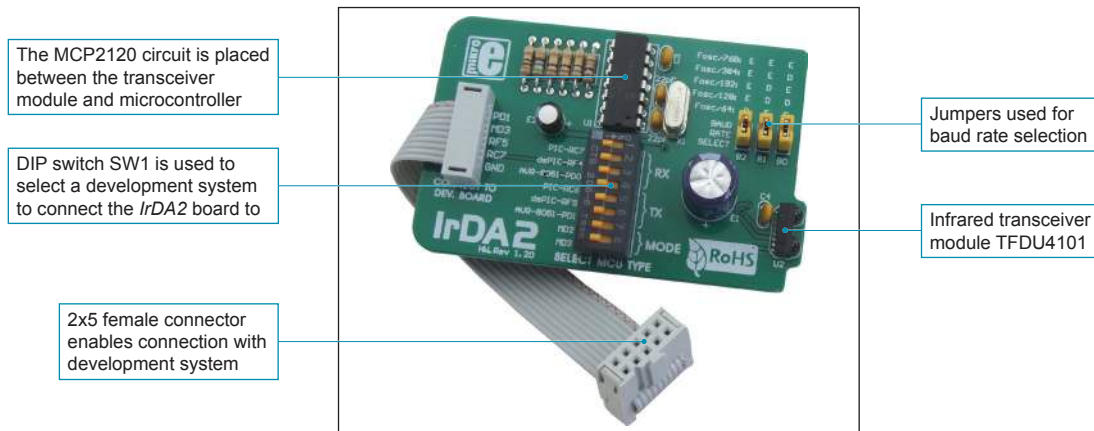

Figure 1: IrDA2 additional board

The TFDU4101 infrared transceiver module can send and receive data in the scope of over 1m at a rate of up to 115.2kbit/s. The baud rate depends on the MCP2120 circuit and position of jumpers B2, B1 and B0. Refer to the table on the right. DIP switch SW1 is used to select a development system to be connected to the additional board, Figure 2.

Labels used in the table have the following meaning:

- E - Jumper is placed (Enable)
- D - Jumper is removed (Disable)

Baud rate selection			
Jumper position			Baud rate
B2	B1	B0	
E	E	E	14.4 kbit/s
E	E	D	28.8 kbit/s
E	D	E	57.6 kbit/s
E	D	D	86.4 kbit/s
D	E	E	172.8 kbit/s

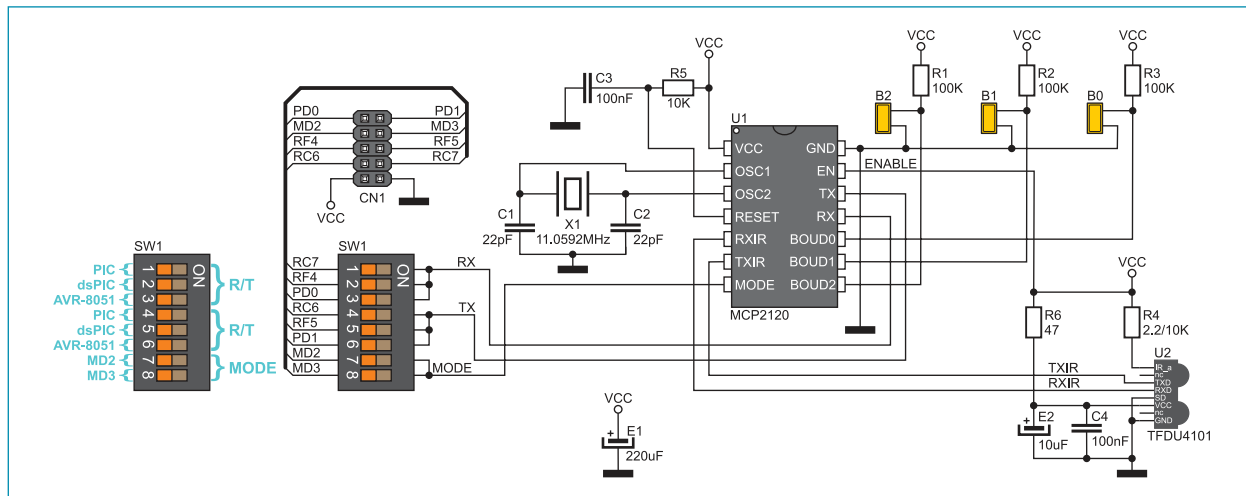

Figure 2: Additional board IrDA2 connection schematic

The function of the pins provided on the 2x5 female connector CN1:

- RC7 - Receive data pin RX for PIC development systems
- RF4 - Receive data pin RX for dsPIC development systems
- PD0 - Receive data pin RX for AVR and 8051 development systems
- RC6 - Transmit data pin TX for PIC development systems
- RF5 - Transmit data pin TX for dsPIC development systems
- PD1 - Transmit data pin TX for AVR i 8051 development systems
- MD2 - Device mode selection for software baud rate operation
- MD3 - Device mode selection for software baud rate operation

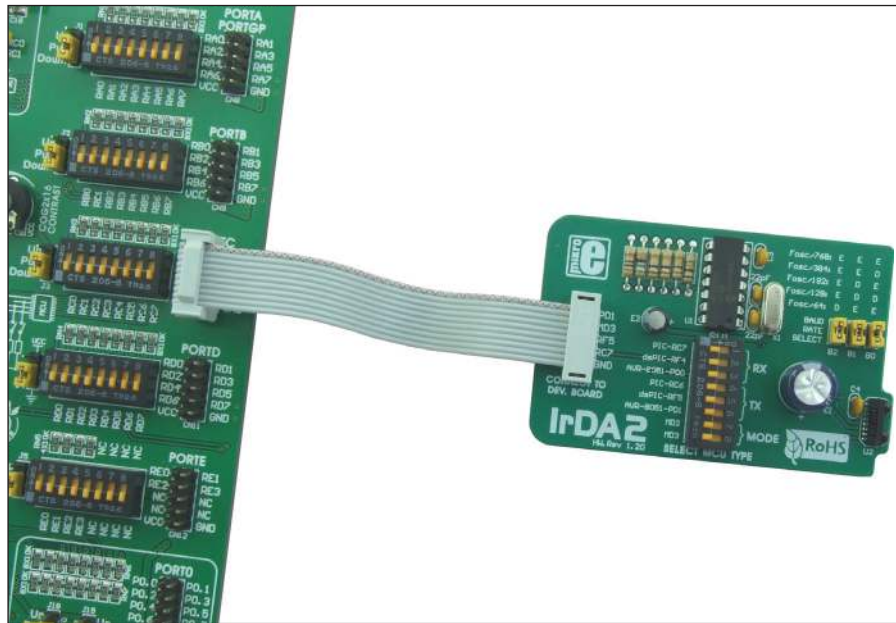

Figure 3: IrDA2 board connected to a development system



**MikroElektronika**  
SOFTWARE AND HARDWARE SOLUTIONS FOR EMBEDDED WORLD ...making it simple

If you want to learn more about our products, please visit our website at [www.mikroe.com](http://www.mikroe.com)

If you are experiencing some problems with any of our products or just need additional information, please place your ticket at [www.mikroe.com/en/support](http://www.mikroe.com/en/support)

If you have any questions, comments or business proposals, do not hesitate to contact us at [office@mikroe.com](mailto:office@mikroe.com)