

Large Air Gap, GMR Transmission Speed Sensor IC for Gear Tooth Sensing

FEATURES AND BENEFITS

- Fully integrated solution has GMR IC, protection capacitor, and back-bias magnet in a single in-line overmolded package
- Innovative GMR technology provides large operational air gap sensing on ferromagnetic targets
- Advanced algorithms for flexible design-in and system compensation, automatically adapts to extreme mechanical changes (air gap) and thermal drifts
- Measures differentially to reject common-mode stray magnetic fields
- Orientation compatible with Hall-effect technology
- Integrated ASIL diagnostics and certified safety design process (optional fault reporting)



PACKAGE:

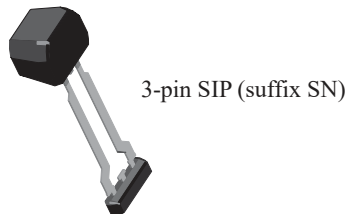

Not to scale

DESCRIPTION

The ATS19480 is a giant magnetoresistance (GMR) integrated circuit (IC) that provides a user-friendly two-wire solution for applications where speed information is required using ferromagnetic gear tooth targets. The fully integrated package includes the GMR IC, a protection capacitor for EMC robustness, and a back-bias magnet in a single in-line package.

The GMR-based IC is designed for use with ferromagnetic gear tooth targets and is orientation-compatible with Hall-effect technology. The fully integrated solution senses at large operating air gaps and over a large air gap range. State-of-the-art GMR technology on a monolithic IC with industry-leading signal processing provides accurate speed information in response to low-level differential magnetic signals. The differential sensing offers inherent rejection of interfering common-mode magnetic fields.

Integrated diagnostics are used to detect an IC failure that would impact output protocol accuracy, providing coverage compatible with ASIL B (assessment pending). Built-in EEPROM scratch memory offers traceability of the device throughout the IC's product lifecycle. ASIL reporting can be enabled or disabled as a product offering depending on the applications' needs.

The ATS19480 is provided in a lead (Pb) free 3-pin SIP package with tin leadframe plating. The SN package includes a GMR IC, a magnet, and capacitor integrated into a single overmold, with an additional molded lead-stabilizing bar for robust shipping and ease of assembly.

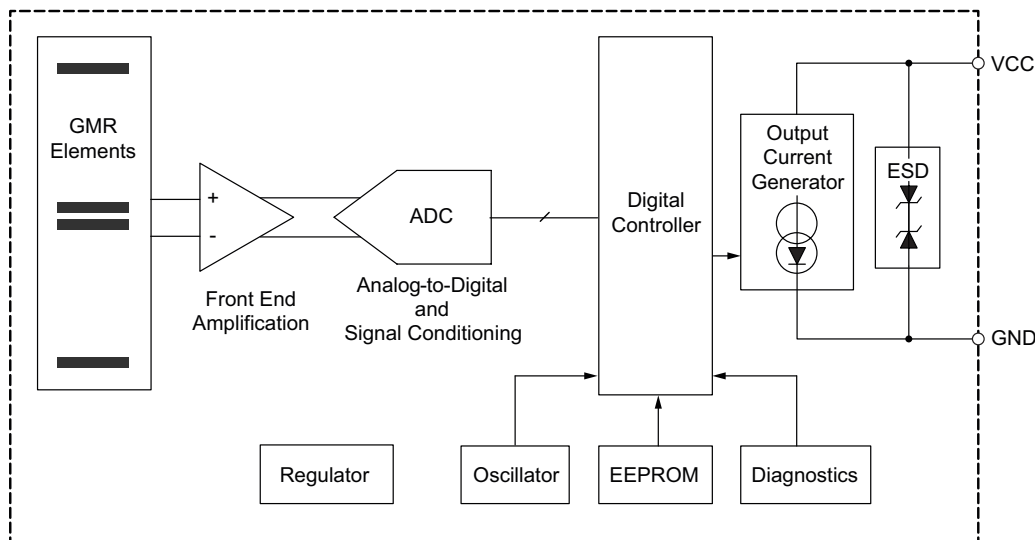

Functional Block Diagram

ATS19480

Large Air Gap, GMR Transmission Speed Sensor IC for Gear Tooth Sensing

SELECTION GUIDE

Part Number	Packing	Fault Detection Mode
ATS19480LSNBTN-A	Tape and reel, 13-in. reel, 800 pieces per reel	Enabled
ATS19480LSNBTN	Tape and reel, 13-in. reel, 800 pieces per reel	Disabled

ABSOLUTE MAXIMUM RATINGS

Characteristic	Symbol	Notes	Rating	Units
Supply Voltage	V_{CC}	Refer to Power Derating section	28	V
Reverse Supply Voltage	V_{RCC}		-18	V
Operating Ambient Temperature	T_A	Range L	-40 to 150	°C
Maximum Junction Temperature	$T_{J(max)}$		165	°C
Storage Temperature	T_{stg}		-65 to 170	°C
Externally Applied Magnetic Flux Density	B	In any direction	500	G

PINOUT DIAGRAM AND LIST

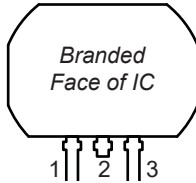

Package SN, 3-Pin SIP Pinout Diagram

Pinout List

Number	Name	Function
1	VCC	Supply Voltage
2	VCC	Supply Voltage
3	GND	Ground

Internal Components

Characteristic	Symbol	Notes	Rating	Units
Nominal Capacitance	C_{SUPPLY}	Connected between VCC and GND; refer to Figure 1	10	nF

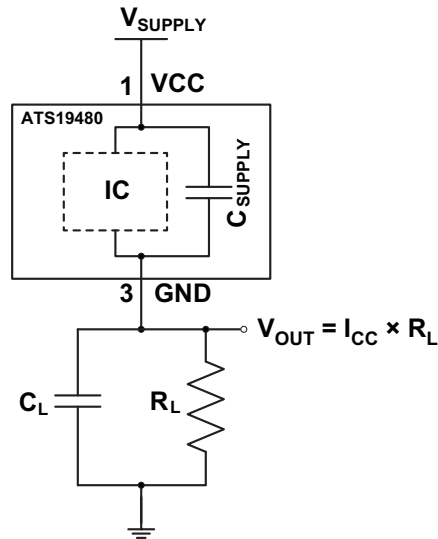

Figure 1: Typical Application Circuit

OPERATING CHARACTERISTICS: Valid throughout full operating and temperature ranges, unless otherwise specified

Characteristic	Symbol	Test Conditions	Min.	Typ. [1]	Max.	Unit
ELECTRICAL SUPPLY CHARACTERISTICS						
Supply Voltage [2]	V_{CC}	Voltage across pin 1 and pin 3; does not include voltage across R_L	4	–	24	V
Undervoltage Lockout	$V_{CC(UV)}$		–	–	3.95	V
Reverse Supply Current [3]	I_{RCC}	$V_{CC} = -18$ V	-10	–	–	mA
Supply Current	$I_{CC(LOW)}$	Low-current state	5.9	–	8	mA
	$I_{CC(HIGH)}$	High-current state	12	–	16	mA
Supply Current Ratio	$I_{CC(HIGH)} / I_{CC(LOW)}$	Ratio of high current to low current (isothermal)	1.9	–	–	–
ASIL Safety Current	I_{FAULT}	$V_{CC} \leq 14$ V, -A (ASIL) variant	1.5	–	3.9	mA
ELECTRICAL PROTECTION CHARACTERISTICS						
Supply Zener Clamp Voltage	$V_{ZSUPPLY}$	$I_{CC} = 19$ mA	28	–	–	V
Reverse Supply Zener Clamp Voltage	$V_{RZSUPPLY}$	$I_{CC} = -3$ mA	–	–	-18	V
POWER-ON STATE CHARACTERISTICS						
Power-On State	POS	$V_{CC} > V_{CC(min)}$	$I_{CC(LOW)}$			–
Power-On Time	t_{PO}	Time from $V_{CC} > V_{CC(min)}$, until device has entered Calibration mode	–	–	1	ms
OUTPUT CHARACTERISTICS						
Output Rise Time	t_r	Voltage measured at pin 3 (see Typical Application Circuit), $R_L = 100 \Omega$, $C_L = 10$ pF, measured between 10% and 90% of signal	0	2	4	μ s
Output Fall Time	t_f	Voltage measured at pin 3 (see Typical Application Circuit), $R_L = 100 \Omega$, $C_L = 10$ pF, measured between 10% and 90% of signal	0	2	4	μ s
Pulse Width, Fault	$t_{w(FAULT)}$	$R_L = 100 \Omega$, $C_L = 10$ pF, pulse duration measured at threshold of $(I_{CC(LOW)} + I_{FAULT}) / 2$; -A (ASIL) variant	4	–	8	ms
Operating Frequency	f_{OP}		0	–	12	kHz
Operational Air Gap Range [4]	AG	Using Reference Target 60-0, tested at 1000 rpm	1.5	–	4.5	mm
Extended Air Gap Range	AG_{EXT}	Using Reference Target 60-0. Output duty cycle may be degraded.	0.5	–	1.5	mm
Total Air Gap Variation During Operation		Momentary interruptions in output sequence permitted; operation within AG range	-4	–	4	mm
Operate Point	B_{OP}	Percentage of IC processed magnetic signals; see Figure 3	–	70	–	%
Release Point	B_{RP}	Percentage of IC processed magnetic signals; see Figure 3	–	30	–	%

Continued on next page...

OPERATING CHARACTERISTICS (continued): Valid throughout full operating and temperature ranges, unless otherwise specified

Characteristic	Symbol	Test Conditions	Min.	Typ. [1]	Max.	Unit
PERFORMANCE CHARACTERISTICS						
Initial Calibration	T_{CAL}	Amount of target rotation (constant direction) after t_{PO} during which output duty cycle not guaranteed; see Figure 2	–	1	2	T_{CYCLE}
First Output Edge		Amount of target rotation (constant direction) following t_{PO} until first electrical output transition; see Figure 2	–	–	1.5	T_{CYCLE}
Tooth-to-Tooth Variation		Using Reference Target 60-0 [5]	–	0.25	–	mm
Output Duty Cycle Tolerance [6]	ΔD	Using Reference Target 60-0 at any static air gap within AG. Limits applied to maximum and minimum measurement for one full revolution of the target, around a mean value established by average value of the IC population at the given AG.	–10	–	10	%
Jitter [7]		1 σ value; using Reference Target 60-0 at static 2.5 mm air gap and 1000 rpm; see Characteristic Plots	–	0.004	–	degrees
THERMAL CHARACTERISTICS						
Package Thermal Resistance [8]	$R_{\theta JA}$	Single-layer PCB with copper limited to solder pads	–	150	–	°C/W

[1] Typical values are at $V_{CC} = 5\text{ V}$ and $T_A = 25^\circ\text{C}$, unless otherwise specified. Performance may vary for individual units, within the maximum and minimum limits.

[2] Maximum voltage must be adjusted for power dissipation and junction temperature; see Power Derating section.

[3] Negative current is defined as conventional current coming out of (sourced from) the specified device terminal.

[4] Operating air gap is dependent on the available magnetic field. The available field is target geometry and material dependent and should be independently characterized.

[5] To determine IC's tolerance to air gap variations on other targets, the complete magnetic system must be analyzed. Due to the nature of the GMR system, contact Allegro for assistance in assessing other targets for use with ATS19480.

[6] Limit applied pertains to full-scale of 0 to 100%, not as a percentage of measured duty cycle.

[7] Jitter is measured on a selected output edge of one target feature, sampled at least 1000 times.

[8] Additional thermal information is available on the Allegro website.

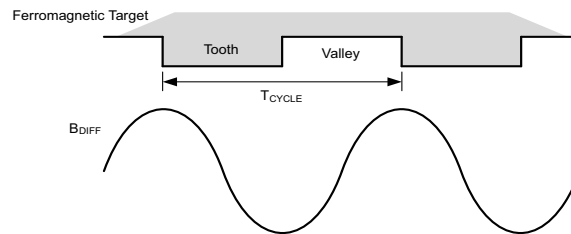

T_{CYCLE} = Target Cycle; the amount of rotation that moves one tooth and valley across the sensor.

B_{DIFF} = The differential magnetic flux density sensed by the sensor.

Figure 2: Definition of T_{CYCLE}

REFERENCE TARGET 60-0 (60-TOOTH TARGET)

Characteristics	Symbol	Test Conditions	Typ.	Units	Symbol Key
Outside Diameter	D_o	Outside diameter of target	120	mm	
Face Width	F	Breadth of tooth, with respect to branded face	6	mm	
Circular Tooth Length	t	Length of tooth, with respect to branded face	3	degrees	
Circular Valley Width	t_v	Length of valley, with respect to branded face	3	degrees	
Tooth Whole Depth	h_t		3	mm	
Material		Low Carbon Steel	-	-	

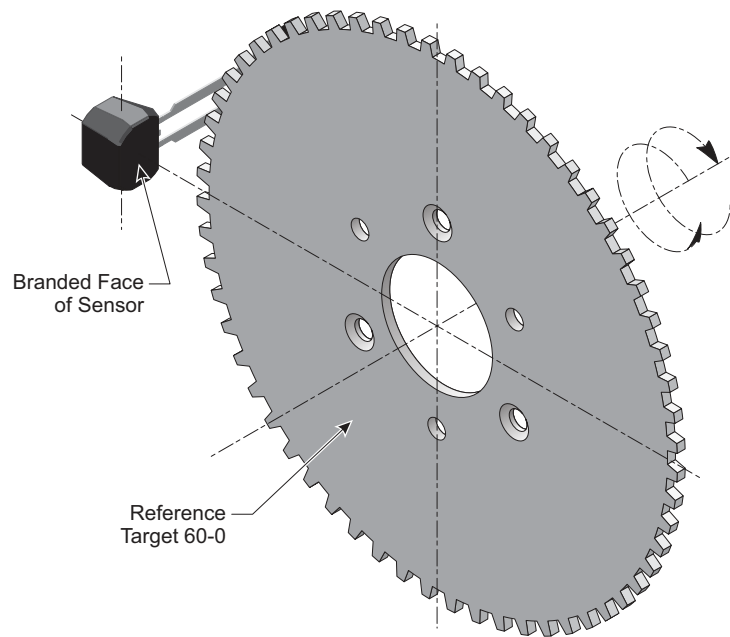

CHARACTERISTIC PLOTS

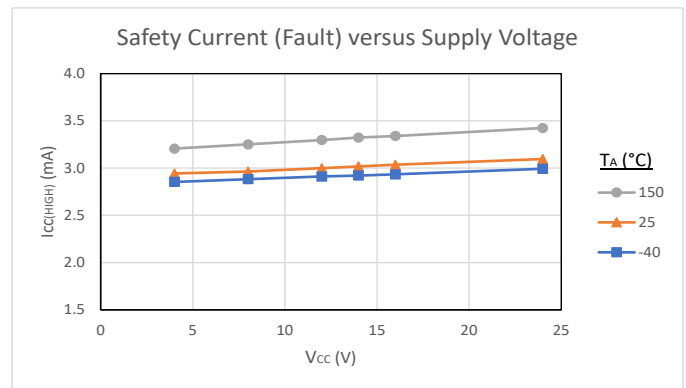
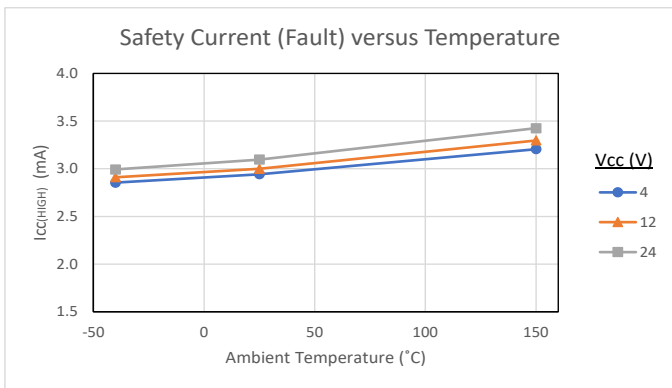
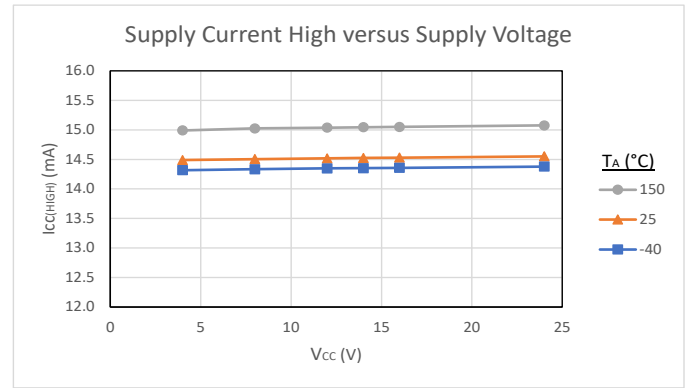
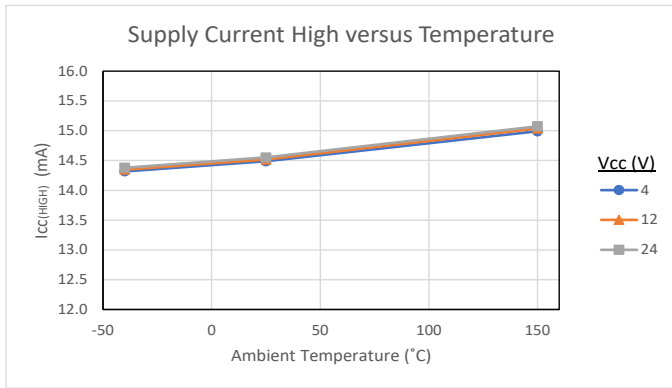
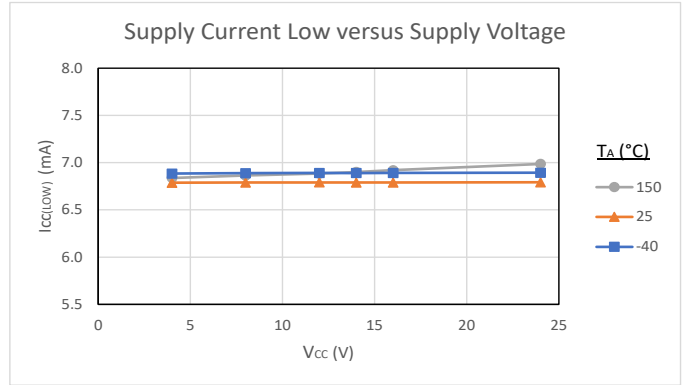
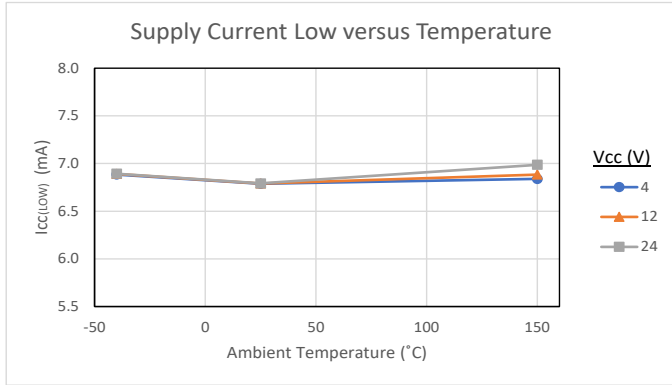

CHARACTERISTIC PLOTS (continued)

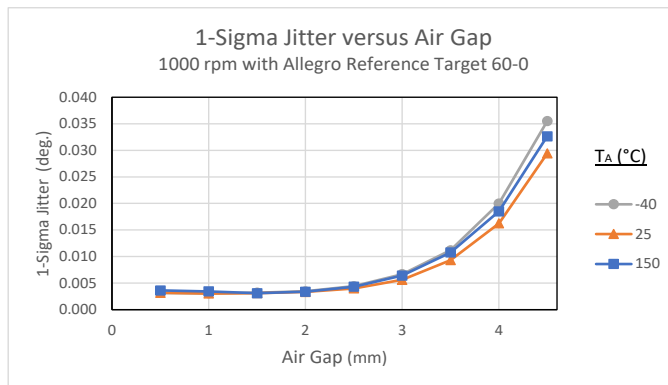
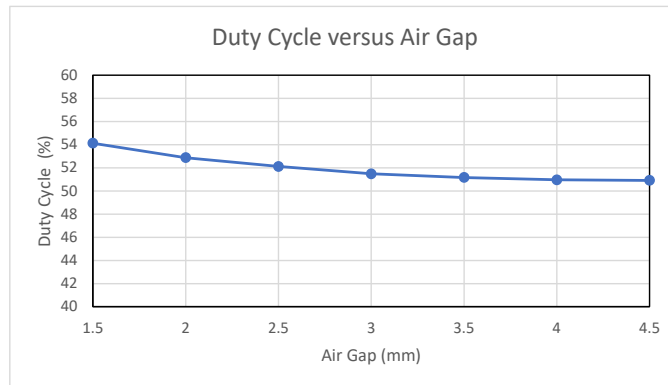
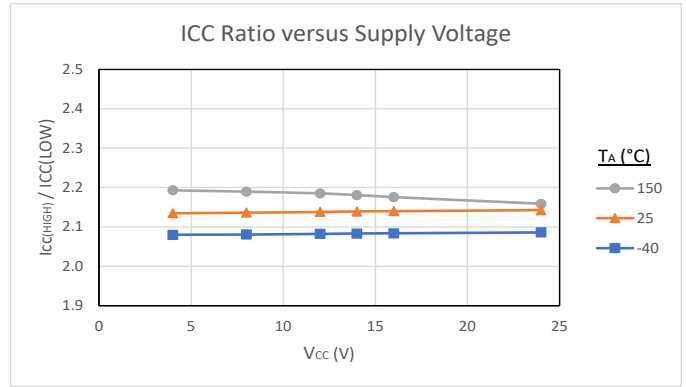
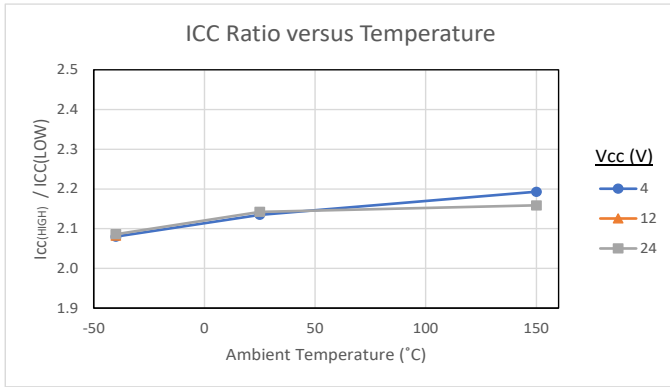

FUNCTIONAL DESCRIPTION

Sensing Technology

The sensor IC contains on-chip GMR elements that are used to detect magnetic signals created by an adjacent target. These transducers provide electrical signals containing information regarding edge position of target rotation. The ATS19480 is intended for use with ferromagnetic targets.

After proper power is applied to the sensor IC, it is capable of providing digital information that is representative of the features of a rotating target. The waveform diagrams in Figure 3 present the automatic translation of the target profiles, through their induced magnetic profiles, to the digital output signal of the sensor IC.

Data Protocol Description

When a target passes in front of the device (opposite the branded face of the package case), the ATS19480 generates an output pulse for each mechanical edge of the target.

Target Design

The ATS19480 is designed to work with a variety of target shapes and sizes in addition to the Reference Target 60-0 in this datasheet. It is recommended that to determine the operating air gap range for each target, the magnetic profile of each should be analyzed.

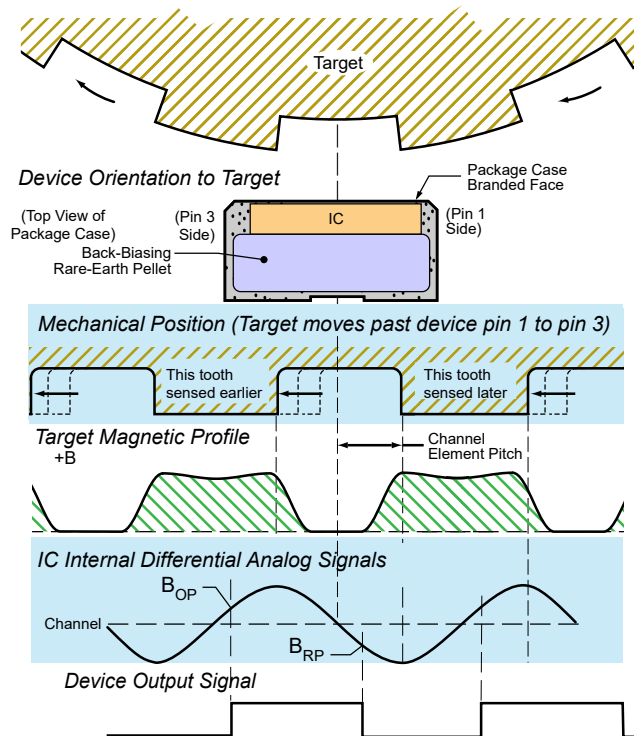

Figure 3: Magnetic Profile

Power-On (Calibration)

After power is applied to the sensor IC, the IC internally detects the magnetic profile of the target. Operation begins with a calibration period, during which the sensor IC provides output edges, but full edge accuracy may not be achieved until Calibration is complete.

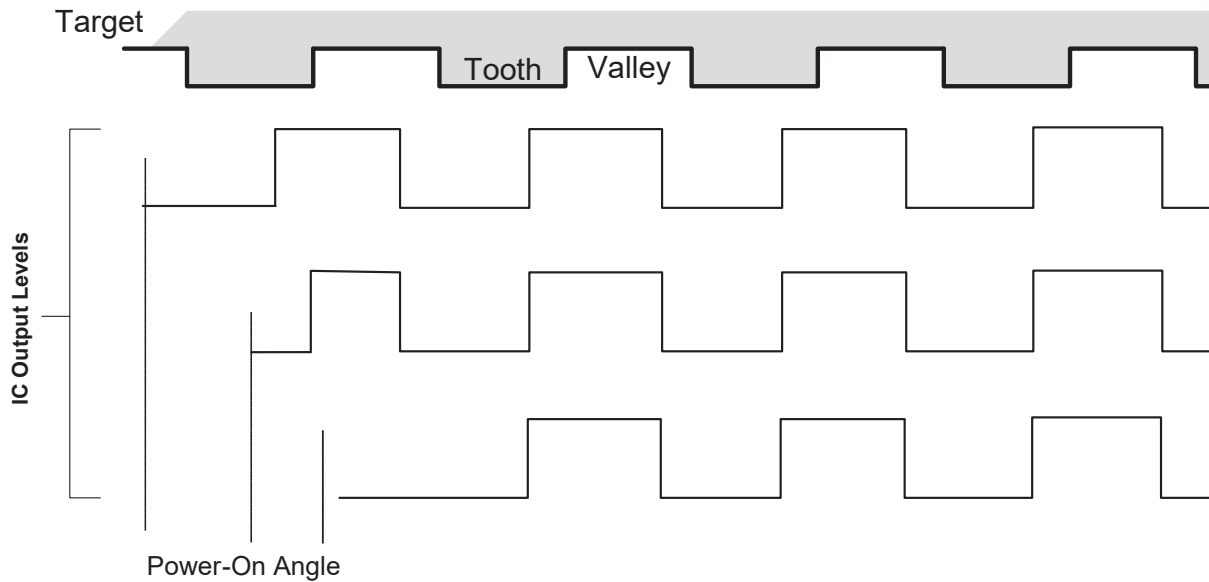

Figure 4: Output after power-on

Safe State Description

The ATS19480 sensor IC contains diagnostic circuitry that will continuously monitor occurrences of failure defects within the IC. Refer to Figure 5 for the output protocol of the ASIL Safe State.

Refer to the ATS19480 Safety Manual for additional details.

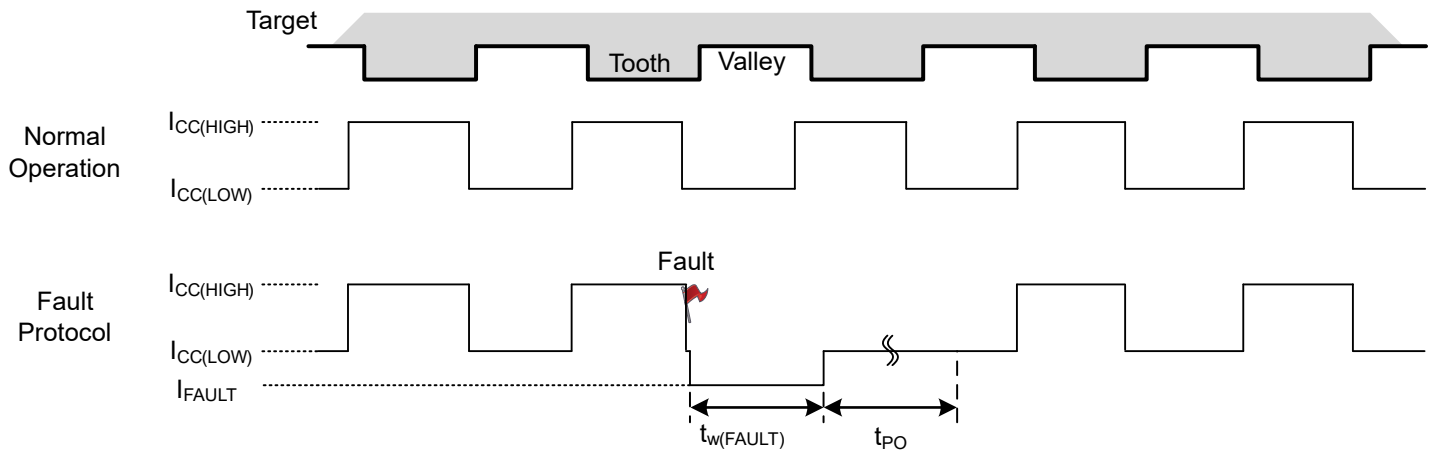

Figure 5: Output Protocol (ASIL Safe State)

POWER DERATING

The device must be operated below the maximum junction temperature of the device ($T_{J(max)}$). Under certain combinations of peak conditions, reliable operation may require derating supplied power or improving the heat dissipation properties of the application. This section presents a procedure for correlating factors affecting operating T_J . (Thermal data is also available on the Allegro website.)

The Package Thermal Resistance ($R_{\theta JA}$) is a figure of merit summarizing the ability of the application and the device to dissipate heat from the junction (die), through all paths to the ambient air. Its primary component is the Effective Thermal Conductivity (K) of the printed circuit board, including adjacent devices and traces. Radiation from the die through the device case ($R_{\theta JC}$) is relatively small component of $R_{\theta JA}$. Ambient air temperature (T_A) and air motion are significant external factors, damped by overmolding.

The effect of varying power levels (Power Dissipation, P_D), can be estimated. The following formulas represent the fundamental relationships used to estimate T_J , at P_D .

$$P_D = V_{IN} \times I_{IN} \quad (1)$$

$$\Delta T = P_D \times R_{\theta JA} \quad (2)$$

$$T_J = T_A + \Delta T \quad (3)$$

For example, given common conditions such as: $T_A = 25^\circ\text{C}$, $V_{CC} = 12\text{ V}$, $I_{CC} = 7.0\text{ mA}$, and $R_{\theta JA} = 150^\circ\text{C/W}$, and $I_{CC} = 7.0\text{ mA}$, then:

$$P_D = V_{CC} \times I_{CC} = 12\text{ V} \times 7.0\text{ mA} = 84\text{ mW}$$

$$\Delta T = P_D \times R_{\theta JA} = 84\text{ mW} \times 150^\circ\text{C/W} = 12.6^\circ\text{C}$$

$$T_J = T_A + \Delta T = 25^\circ\text{C} + 12.6^\circ\text{C} = 37.6^\circ\text{C}$$

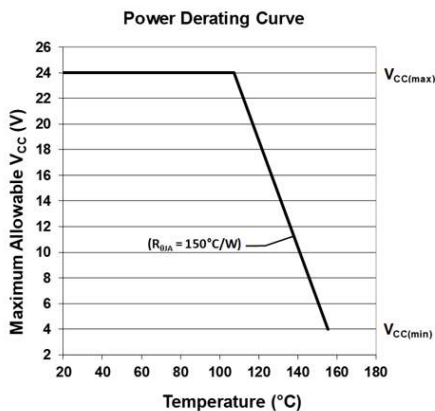

A worst-case estimate, $P_{D(max)}$, represents the maximum allowable power level ($V_{CC(max)}$, $I_{CC(max)}$), without exceeding $T_{J(max)}$, at a selected $R_{\theta JA}$ and T_A

Example: Reliability for V_{CC} at $T_A = 150^\circ\text{C}$, package SN, using a single-layer PCB.

Observe the worst-case ratings for the device, specifically: $R_{\theta JA} = 150^\circ\text{C/W}$, $T_{J(max)} = 165^\circ\text{C}$, $V_{CC(max)} = 24\text{ V}$, and $I_{CC} = 16\text{ mA}$.

Calculate the maximum allowable power level, $P_{D(max)}$. First, invert equation 3:

$$\Delta T_{max} = T_{J(max)} - T_A = 165^\circ\text{C} - 150^\circ\text{C} = 15^\circ\text{C}$$

This provides the allowable increase to T_J resulting from internal power dissipation. Then, invert equation 2:

$$P_{D(max)} = \Delta T_{max} \div R_{\theta JA} = 15^\circ\text{C} \div 150^\circ\text{C/W} = 100\text{ mW}$$

Finally, invert equation 1 with respect to voltage:

$$V_{CC(est)} = P_{D(max)} \div I_{CC(av)} = 100\text{ mW} \div 16\text{ mA} = 6.3\text{ V}$$

The result indicates that, at T_A , the application and device cannot dissipate adequate amounts of heat at voltages $\leq V_{CC(est)}$.

Compare $V_{CC(est)}$ to $V_{CC(max)}$. If $V_{CC(est)} \leq V_{CC(max)}$, then reliable operation between $V_{CC(est)}$ and $V_{CC(max)}$ requires enhanced $R_{\theta JA}$. If $V_{CC(est)} \geq V_{CC(max)}$, then operation between $V_{CC(est)}$ and $V_{CC(max)}$ is reliable under these conditions.

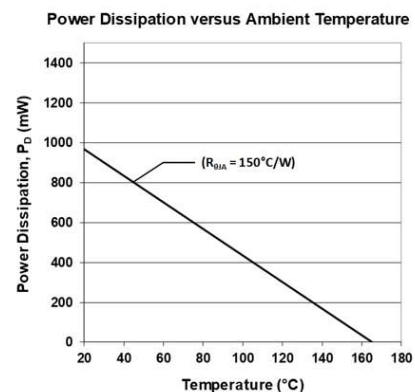

PACKAGE OUTLINE DRAWING

For Reference Only – Not for Tooling Use

(Reference DWG-9206, Rev.2)

Dimensions in millimeters – NOT TO SCALE

Dimensions exclusive of mold flash, gate burs, and dambar protrusions
Exact case and lead configuration at supplier discretion within limits shown

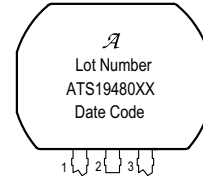
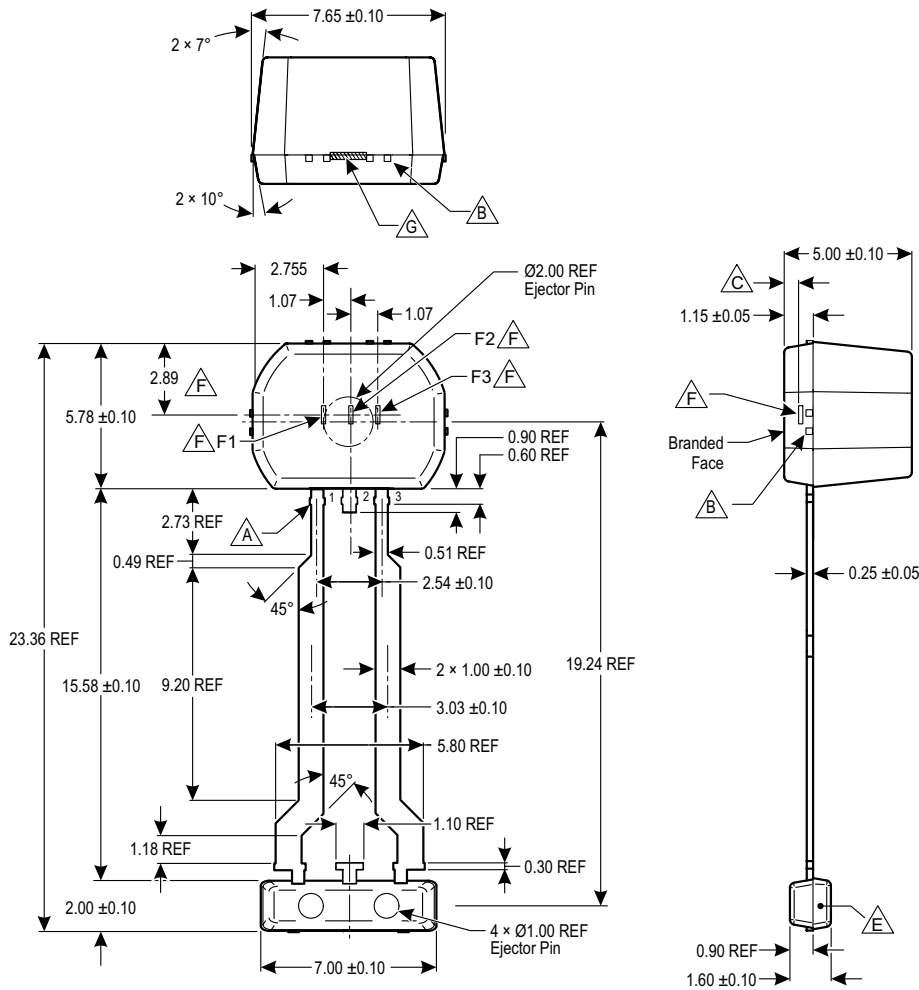

D Standard Branding Reference View

Lines 1, 2, 3, 4: Up to 10 characters, centered

Line 1: Logo A

Line 2: Characters 5, 6, 7, 8, 9, 10, 11 of Assembly Lot Number

Line 3: Part Number:

3 character prefix (ATS),
5 digit part number (19480),
0-2 character part variant (XX).
Example: ATS19480B

Line 4: 4 digit Date Code

Notes:

- A** Dambar removal protrusion (12x)
- B** Tie bars (8x)
- C** Active Area Depth, 0.60 mm
- D** Branding scale and appearance at supplier discretion
- E** Molded lead bar for preventing damage to leads during shipment
- F** GMR elements (F1, F2, F3); not to scale
- G** Gate location

Figure 6: Package SN, 3-Pin SIP

Revision History

Number	Date	Description
–	April 19, 2021	Initial release
1	July 7, 2021	Removed confidential header and other minor editorial updates
2	September 1, 2022	Updated figure 5 reference

Copyright 2022, Allegro MicroSystems.

Allegro MicroSystems reserves the right to make, from time to time, such departures from the detail specifications as may be required to permit improvements in the performance, reliability, or manufacturability of its products. Before placing an order, the user is cautioned to verify that the information being relied upon is current.

Allegro's products are not to be used in any devices or systems, including but not limited to life support devices or systems, in which a failure of Allegro's product can reasonably be expected to cause bodily harm.

The information included herein is believed to be accurate and reliable. However, Allegro MicroSystems assumes no responsibility for its use; nor for any infringement of patents or other rights of third parties which may result from its use.

Copies of this document are considered uncontrolled documents.

For the latest version of this document, visit our website:

www.allegromicro.com