

*New*

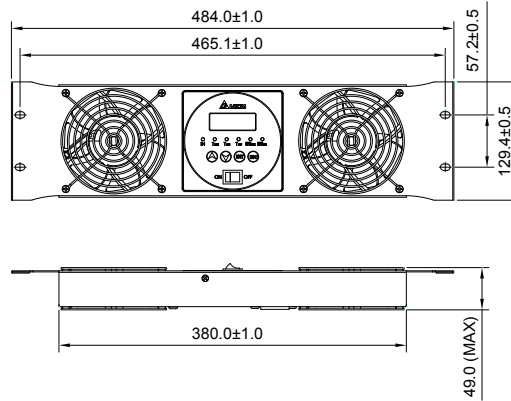

# FTA 484 x 49 x 130 MM SERIES

## DIMENSIONS DRAWING



UNIT:  $\frac{\text{mm}}{\text{(INCH)}}$

- \* Bearing Type  
Ball Bearings
- \* FAN Material  
Impeller & Frame : Plactic (UL 94V-0)
- \* FAN TRAY CASE Material : SPCC
- \* Weight : 1500g (53.95 OZ)
- \* Vertical Mount for front Back Cooling
- \* Real-Time Temperature Display
- \* FAN Fault & Over Temperature Alarm
- \* Air Flow Redundancy
- \* Temperature / Fan Speed Setting

## P & Q CURVE (AT RATED VOLTAGE)

## MOUNTING PANEL CUTOUT

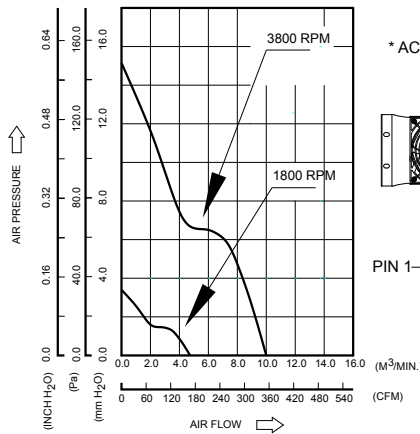

\* AC POWER INPUT :

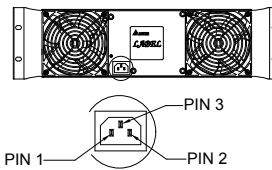

FTA0302AA PIN ASSIGNMENT	
BACKPLANE SOCKET C14 SK-1015	
PIN 1	LINE(L)
PIN 2	NATURE(N)
PIN 3	GROUND(±)

MODEL		Rated Voltage	Operating Voltage Range	Rated Current	Rated Input Power	Speed	Maximum Air Flow		Maximum Air Pressure		Noise
PART NO.	REV.	AC	AC	Amp	Watt	R.P.M.	m <sup>3</sup> /min	CFM	mmH <sub>2</sub> O	IN H <sub>2</sub> O	dB-A
<b>FTA0302AA</b>		110 or 220	100 to 240	0.65	65	1800/3800	9.84	335	14.2	0.056	63

- \* Function type is optional.
- \* The max. air flow and the speed are measured in free air ; max. air pressure is measured at zero air flow.
- \* Noise is measured in anechoic chamber in free air, one meter from intake side.
- \* All readings are typical values at rated voltage.
- \* Specifications are subject to change without notice.