

DAC1401D125

Dual 14-bit DAC, up to 125 Msps

Rev. 03 — 2 July 2012

Product data sheet

1. General description

The DAC1401D125 is a dual port, high-speed, 2-channel CMOS Digital-to-Analog Converter (DAC), optimized for high dynamic performance with low power dissipation. Supporting an update rate of up to 125 Msps, the DAC1401D125 is suitable for Direct IF applications.

Separate write inputs allow data to be written to the two DAC ports independently of one another. Two separate clocks control the update rate of each DAC port.

The DAC1401D125 can interface two separate data ports or one single interleaved high-speed data port. In Interleaved mode, the input data stream is demultiplexed into its original I and Q data and latched. The I and Q data is then converted by the two DACs and updated at half the input data rate.

Each DAC port has a high-impedance differential current output, suitable for both single-ended and differential analog output configurations.

The DAC1401D125 is pin compatible with the AD9767, DAC2904 and DAC5672.

2. Features and benefits

- Dual 14-bit resolution
- 125 Msps update rate
- Single 3.3 V supply
- Dual-port or Interleaved data modes
- 1.8 V, 3.3 V and 5 V compatible digital inputs
- Internal and external reference
- 2 mA to 20 mA full-scale output current
- Typical 185 mW power dissipation
- 16 mW power-down
- SFDR: 81 dBc; $f_o = 1$ MHz; $f_s = 52$ Msps
- SFDR: 79 dBc; $f_o = 10.4$ MHz; $f_s = 78$ Msps
- SFDR: 75 dBc; $f_o = 1$ MHz; $f_s = 52$ Msps; -12 dBFS
- LQFP48 package
- Industrial temperature range of -40 °C to $+85$ °C

3. Applications

- Quadrature modulation
- Medical/test instrumentation
- Direct IF applications
- Direct digital frequency synthesis
- Arbitrary waveform generator



4. Ordering information

Table 1. Ordering information

Type number	Package		Version
	Name	Description	
DAC1401D125HL	LQFP48	plastic low profile quad flat package; 48 leads; body 7 × 7 × 1.4 mm	SOT313-2

5. Block diagram

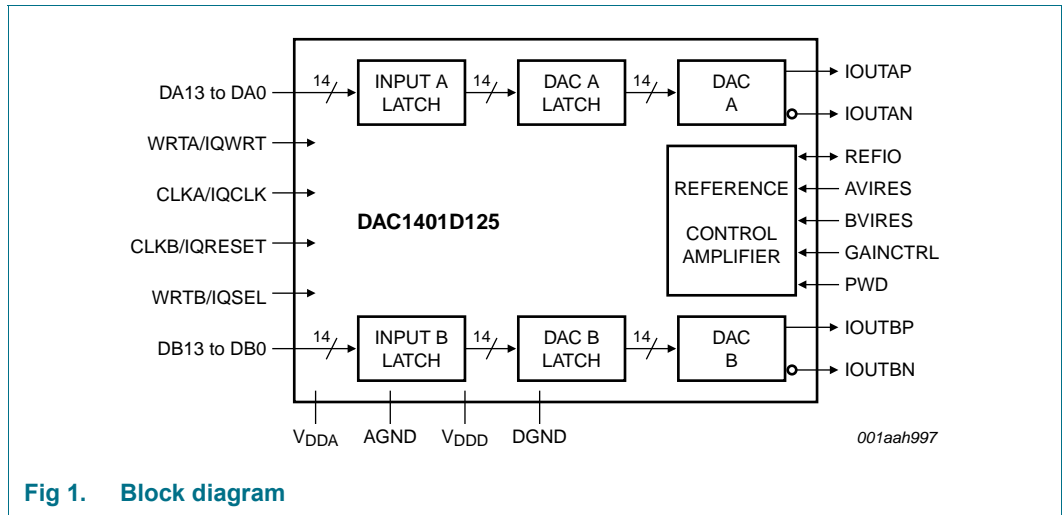

Fig 1. Block diagram

6. Pinning information

6.1 Pinning

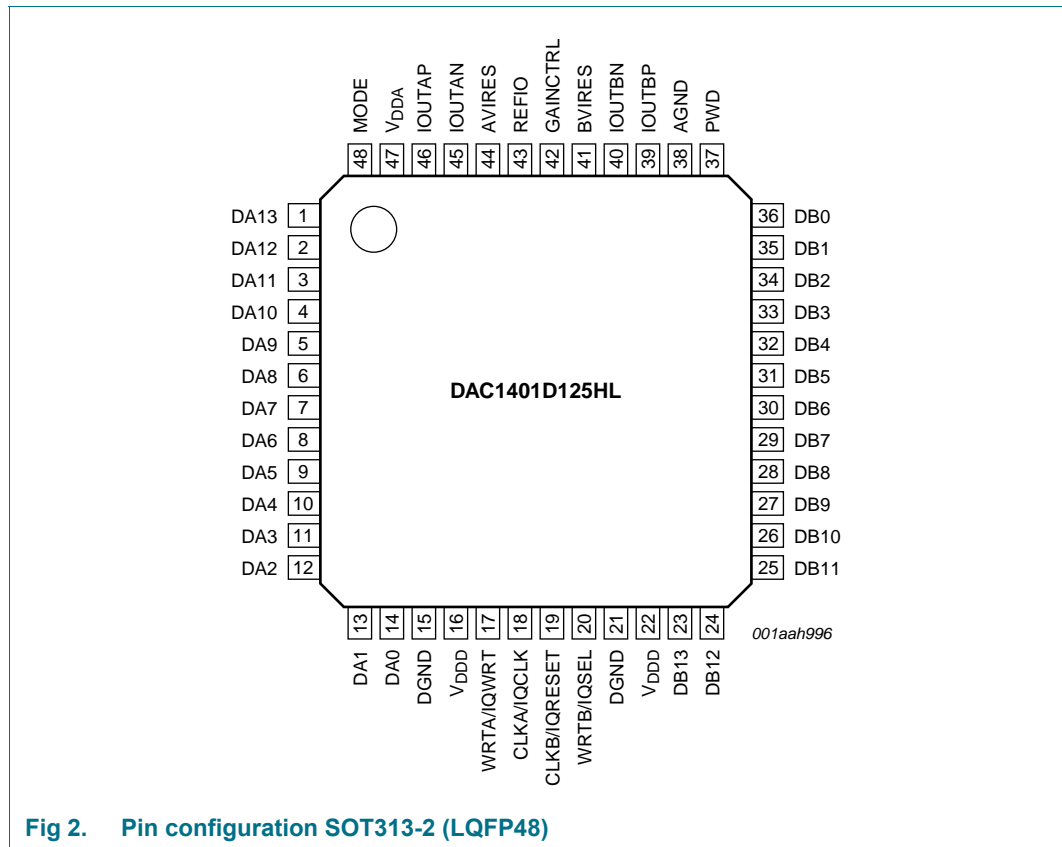

Fig 2. Pin configuration SOT313-2 (LQFP48)

6.2 Pin description

Table 2. Pin description

Symbol	Pin	Type ^[1]	Description
DA13	1	I	DAC A data input bit 13 (MSB)
DA12	2	I	DAC A data input bit 12
DA11	3	I	DAC A data input bit 11
DA10	4	I	DAC A data input bit 10
DA9	5	I	DAC A data input bit 9
DA8	6	I	DAC A data input bit 8
DA7	7	I	DAC A data input bit 7
DA6	8	I	DAC A data input bit 6
DA5	9	I	DAC A data input bit 5
DA4	10	I	DAC A data input bit 4
DA3	11	I	DAC A data input bit 3
DA2	12	I	DAC A data input bit 2
DA1	13	I	DAC A data input bit 1

Table 2. Pin description ...continued

Symbol	Pin	Type ^[1]	Description
DA0	14	I	DAC A data input bit 0 (LSB)
DGND	15	G	digital ground
V _{DD}	16	S	digital supply voltage
WRTA/IQWRT	17	I	Input write port A Input write IQ in Interleaved mode
CLKA/IQCLK	18	I	Input clock port A Input clock IQ in Interleaved mode
CLKB/IQRESET	19	I	Input clock port B reset IQ in Interleaved mode
WRTB/IQSEL	20	I	Input write port B select IQ in Interleaved mode
DGND	21	G	digital ground
V _{DD}	22	S	digital supply voltage
DB13	23	I	DAC B data input bit 13 (MSB)
DB12	24	I	DAC B data input bit 12
DB11	25	I	DAC B data input bit 11
DB10	26	I	DAC B data input bit 10
DB9	27	I	DAC B data input bit 9
DB8	28	I	DAC B data input bit 8
DB7	29	I	DAC B data input bit 7
DB6	30	I	DAC B data input bit 6
DB5	31	I	DAC B data input bit 5
DB4	32	I	DAC B data input bit 4
DB3	33	I	DAC B data input bit 3
DB2	34	I	DAC B data input bit 2
DB1	35	I	DAC B data input bit 1
DB0	36	I	DAC B data input bit 0 (LSB)
PWD	37	I	Power-down mode
AGND	38	G	analog ground
IOUTBP	39	O	DAC B current output
IOUTBN	40	O	complementary DAC B current output
BVIRE	41	I	adjust DAC B for full-scale output current
GAINCTRL	42	I	gain control mode
REFIO	43	I/O	reference input/output
AVIRE	44	I	adjust DAC A for full-scale output current
IOUTAN	45	O	complementary DAC A current output
IOUTAP	46	O	DAC A current output
V _{DDA}	47	S	analog supply voltage
MODE	48	I	select between Dual port mode or Interleaved mode

[1] Type description: S = Supply; G = Ground; I = Input; O = Output; I/O = Input/Output.

7. Limiting values

Table 3. Limiting values

In accordance with the Absolute Maximum Rating System (IEC 60134).

Symbol	Parameter	Conditions	Min	Max	Unit
V_{DDD}	digital supply voltage		[1] -0.3	+5.0	V
V_{DDA}	analog supply voltage		[1] -0.3	+5.0	V
ΔV_{DD}	supply voltage difference	between analog and digital supply voltage	-150	+150	mV
V_I	input voltage	digital inputs referenced to DGND	-0.3	+5.5	V
		pins REFIO, AVIRES, BVIRES referenced to AGND	-0.3	+5.5	V
V_O	output voltage	pins IOUTAP, IOUTAN, IOUTBP and IOUTBN referenced to AGND	-0.3	$V_{DDA} + 0.3$	V
T_{stg}	storage temperature		-55	+150	°C
T_{amb}	ambient temperature		-40	+85	°C
T_j	junction temperature		-	125	°C

[1] All supplies are connected together.

8. Thermal characteristics

Table 4. Thermal characteristics

Symbol	Parameter	Conditions	Typ	Unit
$R_{th(j-a)}$	thermal resistance from junction to ambient	in free air	89.3	K/W
$R_{th(c-a)}$	thermal resistance from case to ambient	in free air	60.6	K/W

9. Characteristics

Table 5. Characteristics

$V_{DDD} = V_{DDA} = 3.3$ V; AGND and DGND connected together; $I_{O(fs)} = 20$ mA and $T_{amb} = -40$ °C to +85 °C; typical values measured at $T_{amb} = 25$ °C.

Symbol	Parameter	Conditions	Min	Typ	Max	Unit
Supplies						
V_{DDD}	digital supply voltage		3.0	3.3	3.65	V
V_{DDA}	analog supply voltage		3.0	3.3	3.65	V
I_{DDD}	digital supply current	$f_s = 65$ Msps, $f_o = 1$ MHz, $V_{DD} = 3.0$ V to 3.6 V	-	6	7	mA
I_{DDA}	analog supply current	$f_s = 65$ Msps, $f_o = 1$ MHz, $V_{DD} = 3.0$ V to 3.6 V	-	50	65	mA
P_{tot}	total power dissipation	$f_s = 65$ Msps, $f_o = 1$ MHz, $V_{DD} = 3.0$ V to 3.6 V	-	185	260	mW
P_{pd}	power dissipation in power-down mode		-	16.5	-	mW

Table 5. Characteristics ...continued

$V_{DDD} = V_{DDA} = 3.3\text{ V}$; AGND and DGND connected together; $I_{O(fs)} = 20\text{ mA}$ and $T_{amb} = -40\text{ °C}$ to $+85\text{ °C}$; typical values measured at $T_{amb} = 25\text{ °C}$.

Symbol	Parameter	Conditions	Min	Typ	Max	Unit
Digital inputs						
V_{IL}	LOW-level input voltage		DGND	-	0.9	V
V_{IH}	HIGH-level input voltage		1.3	-	V_{DDD}	V
I_{IL}	LOW-level input current	$V_{IL} = 0.9\text{ V}$	-	5	-	μA
I_{IH}	HIGH-level input current	$V_{IH} = 1.3\text{ V}$	-	5	-	μA
C_i	input capacitance		[1] -	5	-	pF
Analog outputs (IOUTAP, IOUTAN, IOUTBP and IOUTBN)						
$I_{O(fs)}$	full-scale output current	differential outputs	2	-	20	mA
V_O	output voltage	compliance range	[1] -1	-	+1.25	V
R_O	output resistance		[1] -	150	-	k Ω
C_O	output capacitance		[1] -	3	-	pF
Reference voltage input/output (REFIO)						
$V_{O(ref)}$	reference output voltage		1.21	1.26	1.31	V
$I_{O(ref)}$	reference output current		[1] -	100	-	nA
V_i	input voltage	compliance range	1.0	-	1.26	V
R_i	input resistance		-	1	-	M Ω
Input timing see Figure 18						
f_s	sampling frequency		-	-	125	Msps
$t_{w(WRT)}$	WRT pulse width	pins WRTA, WRTB	2	-	-	ns
$t_{w(CLK)}$	CLK pulse width	pins CLKA, CLKB	2	-	-	ns
$t_{h(i)}$	input hold time		1	-	-	ns
$t_{su(i)}$	input set-up time		1.8	-	-	ns
Output timing (IOUTAP, IOUTAN, IOUTBP, IOUTBN)						
t_d	delay time			1	-	ns
t_t	transition time	rising or falling transition (10 % to 90 % or 90 % to 10 %)	[1] -	0.6	-	ns
t_s	settling time	$\pm 1\text{ LSB}$	[1] -	43	-	ns
Static linearity						
INL	integral non-linearity	25 °C	± 1.60	± 2.15	± 2.90	LSB
		-40 °C to +85 °C	± 1.25	-	± 2.95	LSB
DNL	differential non-linearity	-40 °C to +85 °C	± 0.55	± 0.75	± 1.10	LSB
Static accuracy (relative to full-scale) with GAINCTRL = 0						
E_{offset}	offset error		-0.02	-	+0.02	%
E_G	gain error	with external reference	-1.9	± 1.5	+2.5	%
		with internal reference	-2.9	± 2.1	+2.9	%
ΔG	gain mismatch	between DAC A and DAC B	-0.5	± 0.05	+0.5	%

Table 5. Characteristics ...continued

$V_{DD} = V_{DDA} = 3.3$ V; AGND and DGND connected together; $I_{O(fs)} = 20$ mA and $T_{amb} = -40$ °C to $+85$ °C; typical values measured at $T_{amb} = 25$ °C.

Symbol	Parameter	Conditions	Min	Typ	Max	Unit
Dynamic performance						
SFDR	spurious free dynamic range	B = Nyquist				
		$f_s = 52$ Msps; $f_o = 1$ MHz				
		0 dBFS	-	81	-	dBc
		-6 dBFS	-	80	-	dBc
		-12 dBFS	-	75	-	dBc
		$f_s = 52$ Msps; 0 dBFS				
		$f_o = 5.24$ MHz	-	79	-	dBc
		$f_s = 78$ Msps; 0 dBFS				
		$f_o = 10.4$ MHz	-	79	-	dBc
		$f_o = 15.7$ MHz	-	72	-	dBc
		$f_s = 100$ Msps; 0 dBFS				
		$f_o = 5.04$ MHz	-	77	-	dBc
		$f_o = 20.2$ MHz	61	69	-	dBc
		$f_s = 125$ Msps; 0 dBFS				
		$f_o = 20.1$ MHz	-	69	-	dBc
Within a Window						
THD	total harmonic distortion	$f_s = 52$ Msps; $f_o = 1$ MHz;	-	90	-	dBc
		2 MHz span				
		$f_s = 52$ Msps; $f_o = 5.24$ MHz;	-	88	-	dBc
		10 MHz span				
		$f_s = 78$ Msps; $f_o = 5.26$ MHz;	-	92	-	dBc
2 MHz span						
$f_s = 125$ Msps; $f_o = 5.04$ MHz;	80	92	-	dBc		
10 MHz span						
MTPR	multitone power ratio	$f_s = 65$ Msps;	-	80	-	dBc
		2 MHz $< f_o < 2.99$ MHz; 8 tones				
		at 110 kHz spacing at 0 dB				
		full-scale				
NSD	noise spectral density	$f_s = 100$ Msps; $f_o = 5.04$ MHz	-	-149	-	dBm/Hz
α_{CS}	channel separation	$f_s = 78$ Msps; $f_o = 10.4$ MHz	-	88.0	-	dBc
		$f_s = 125$ Msps; $f_o = 20.1$ MHz	-	83.5	-	dBc

[1] Guaranteed by design.

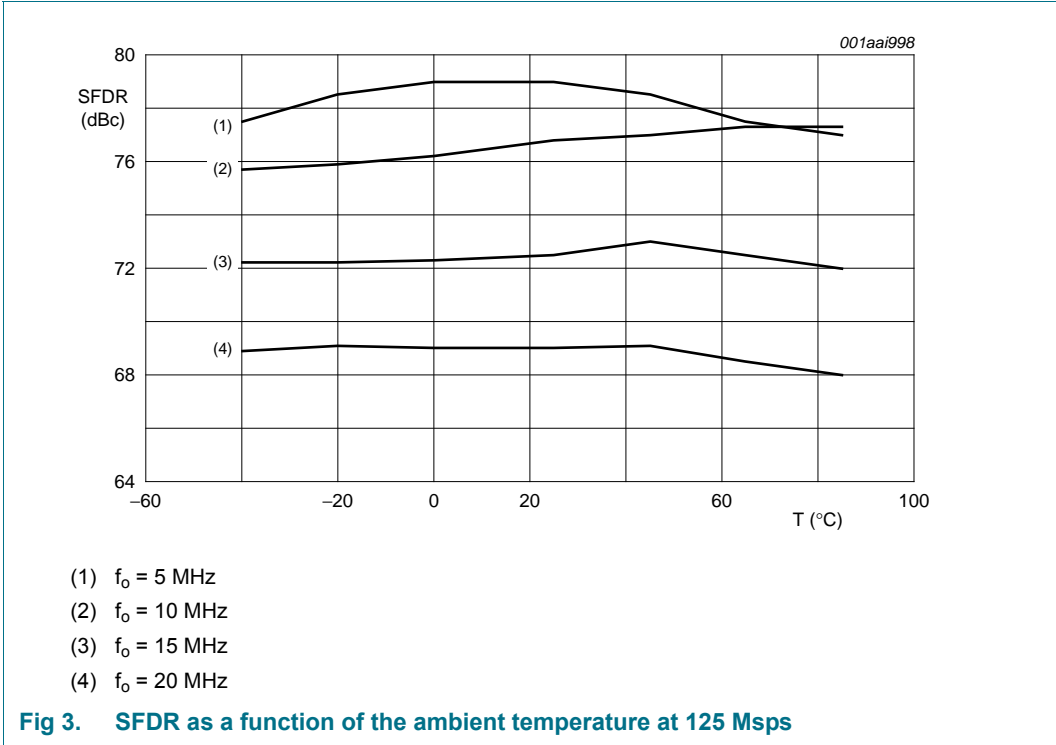

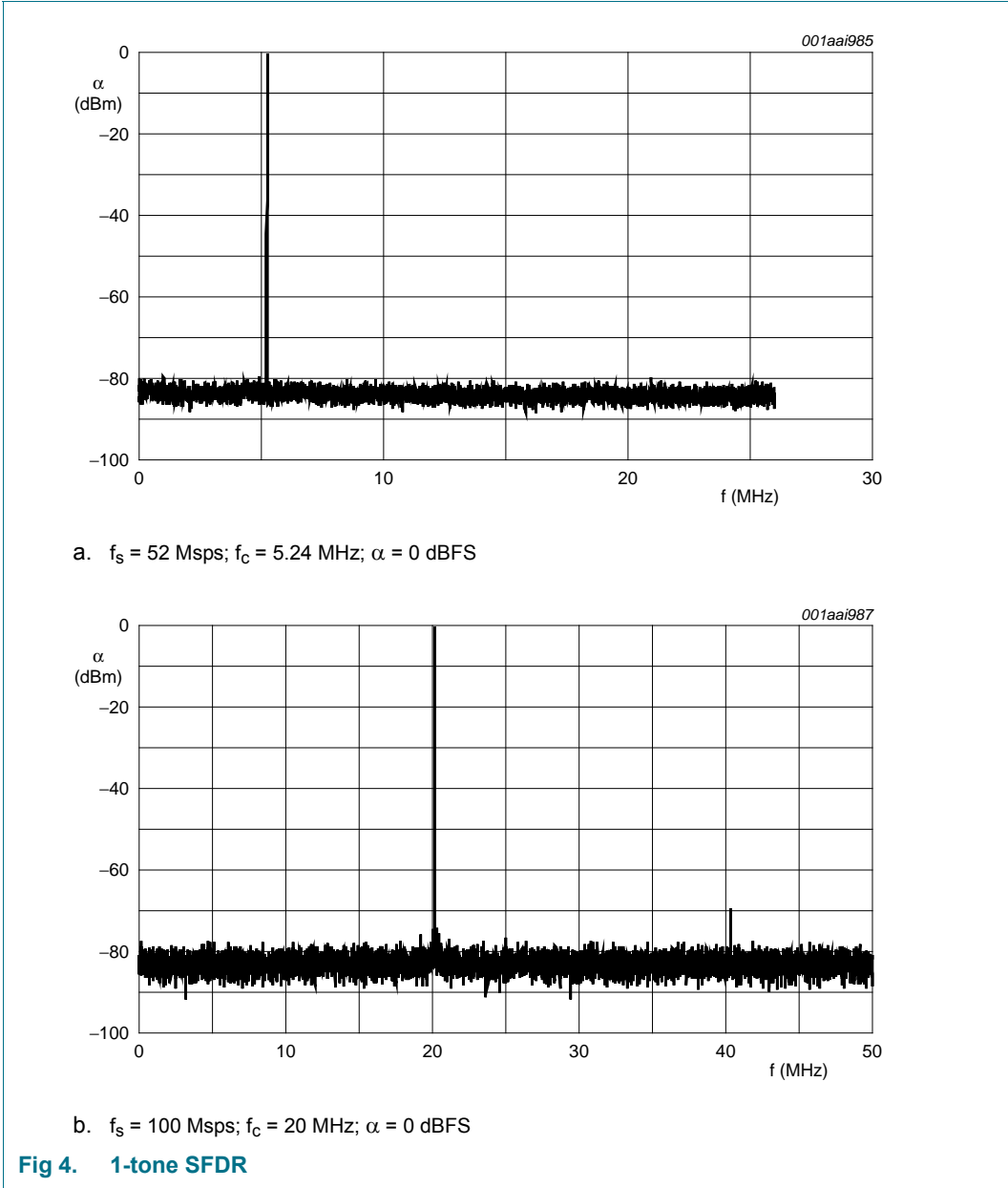

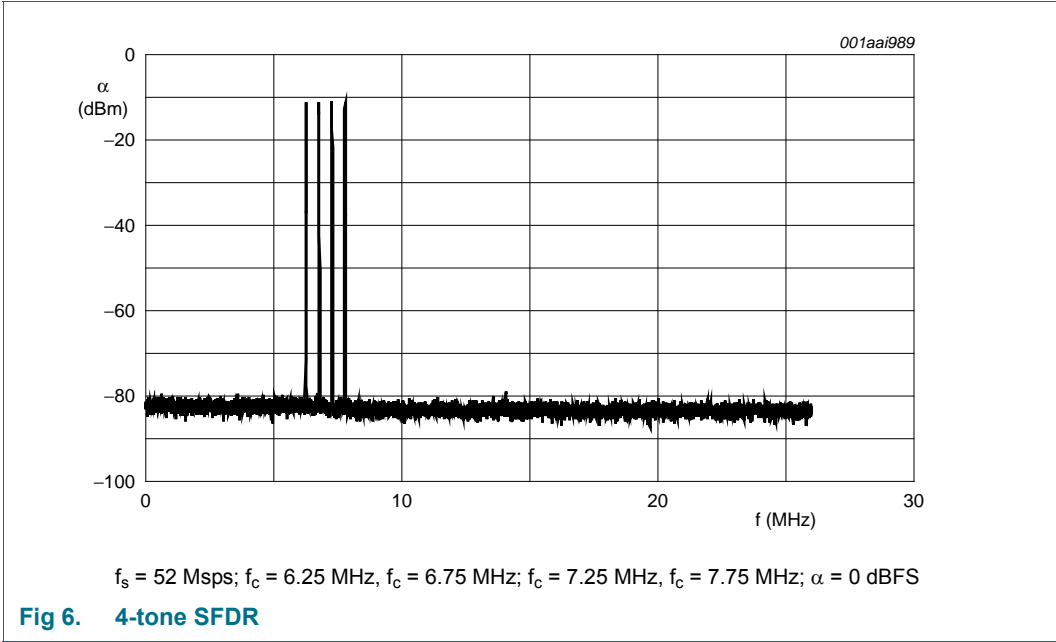
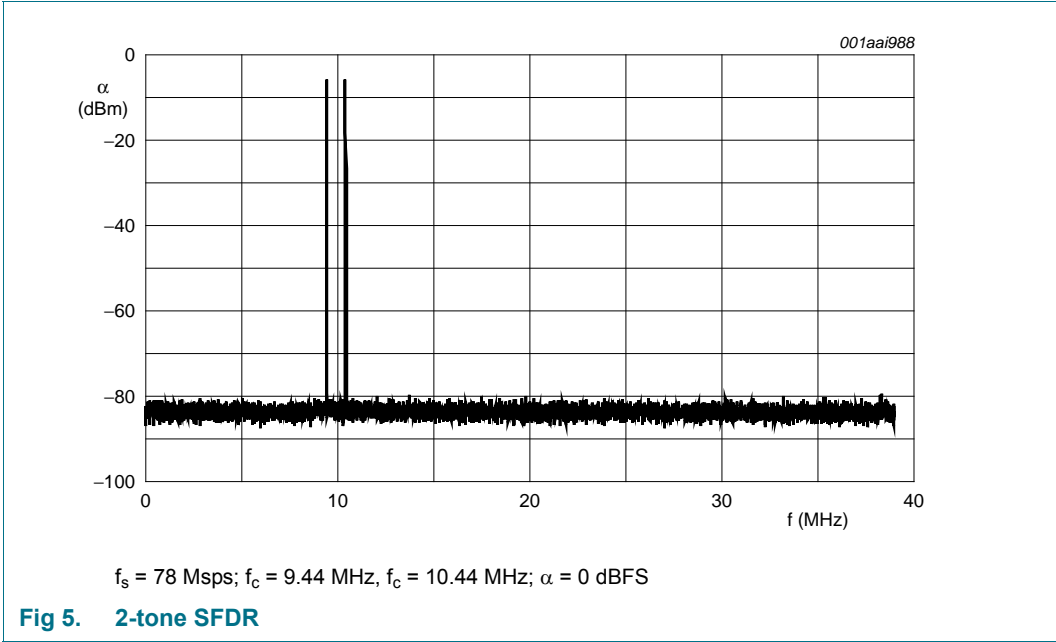

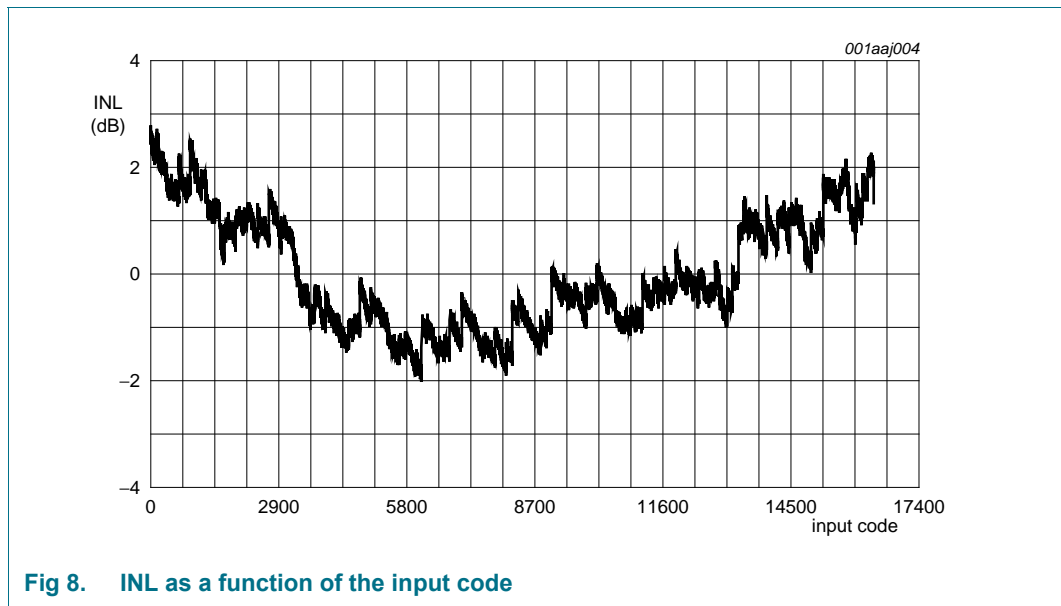
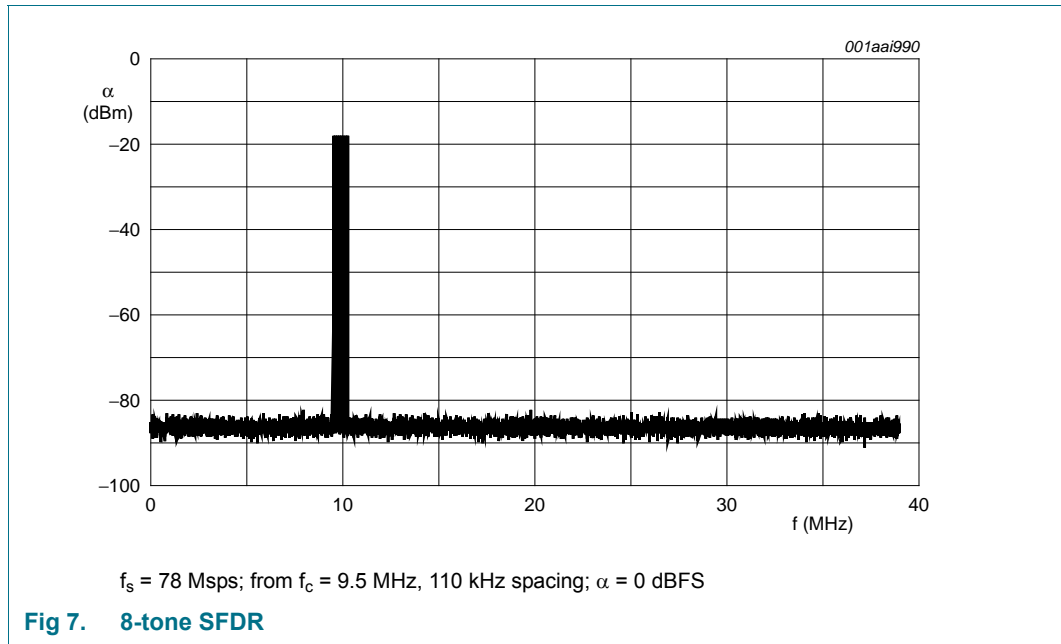

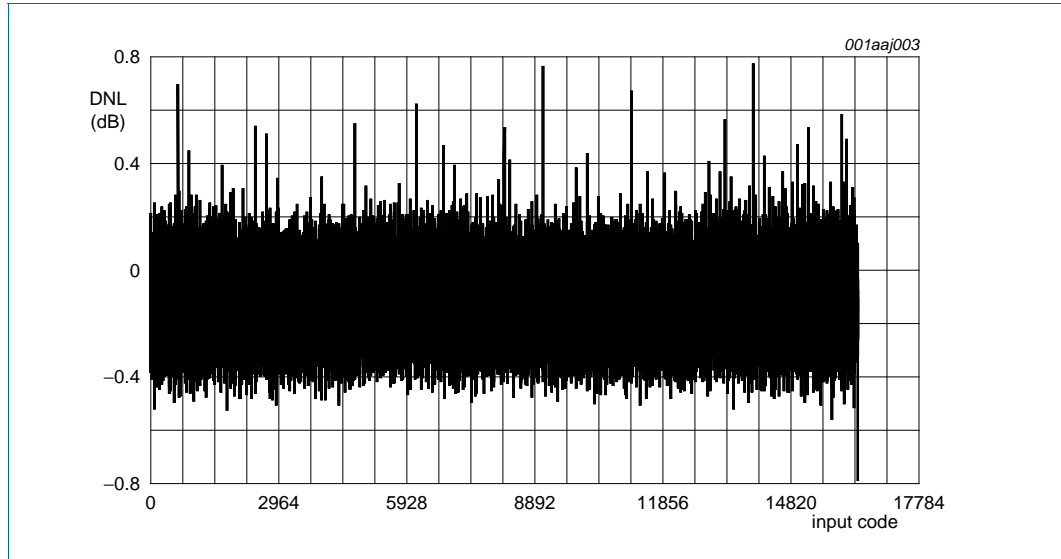

Fig 9. DNL as a function of the input code

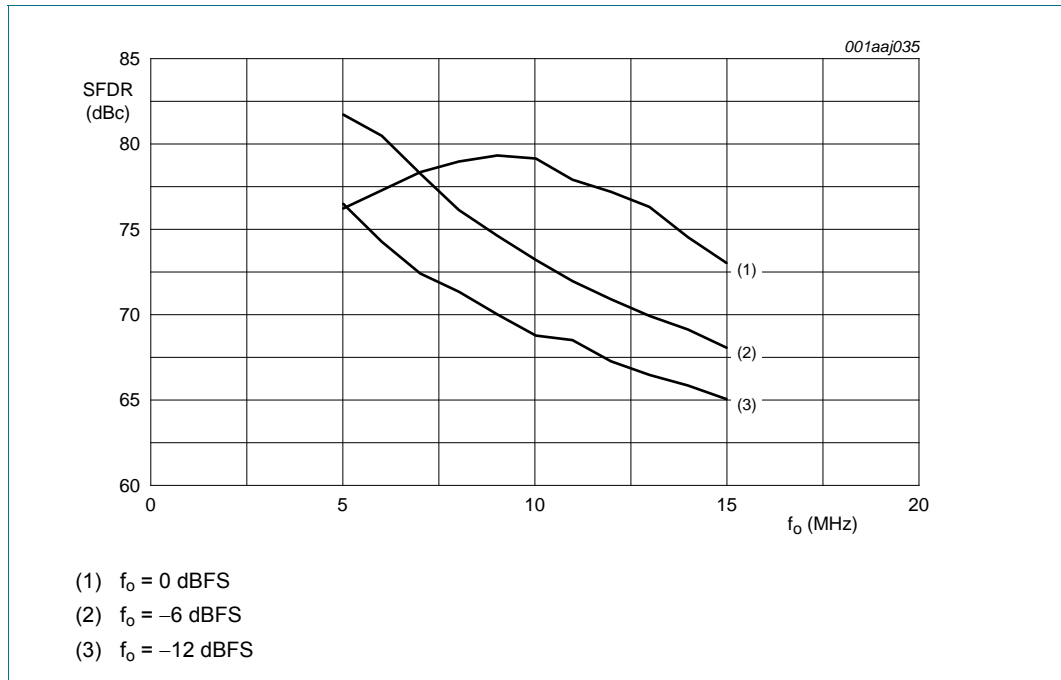
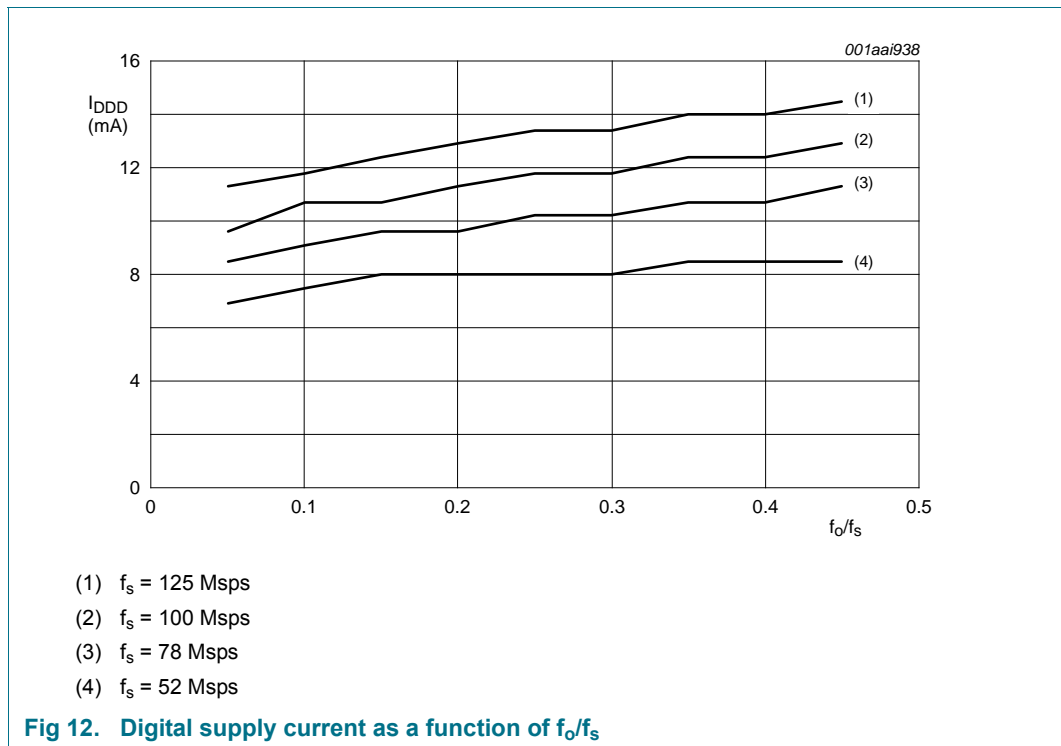
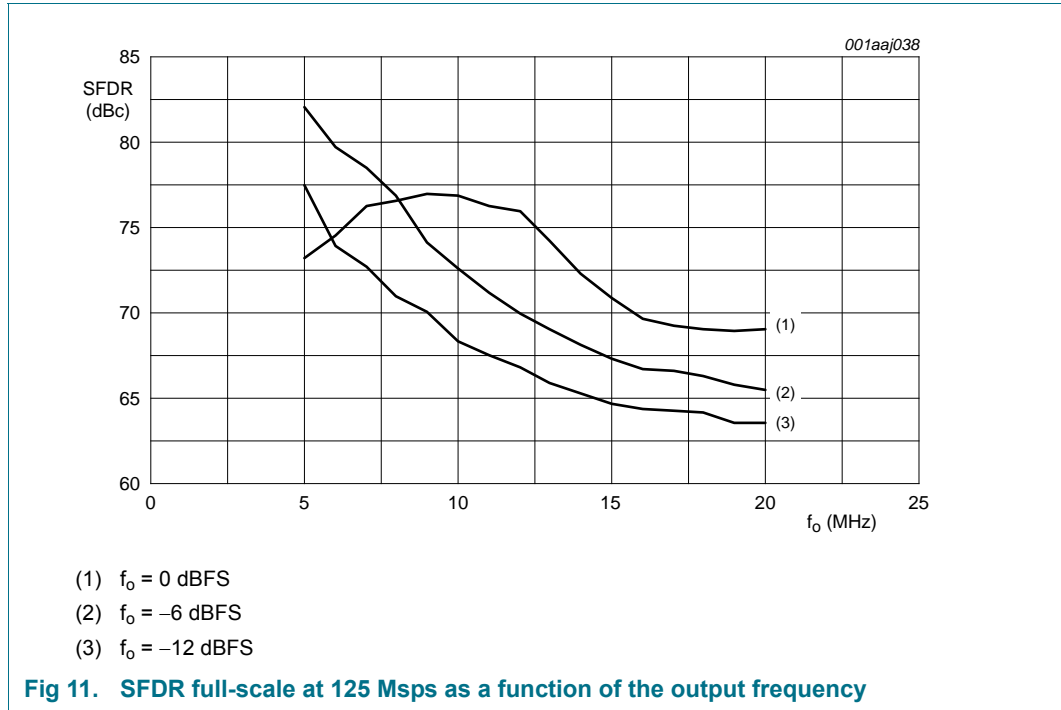

Fig 10. SFDR full-scale at 78 Mps as a function of the output frequency



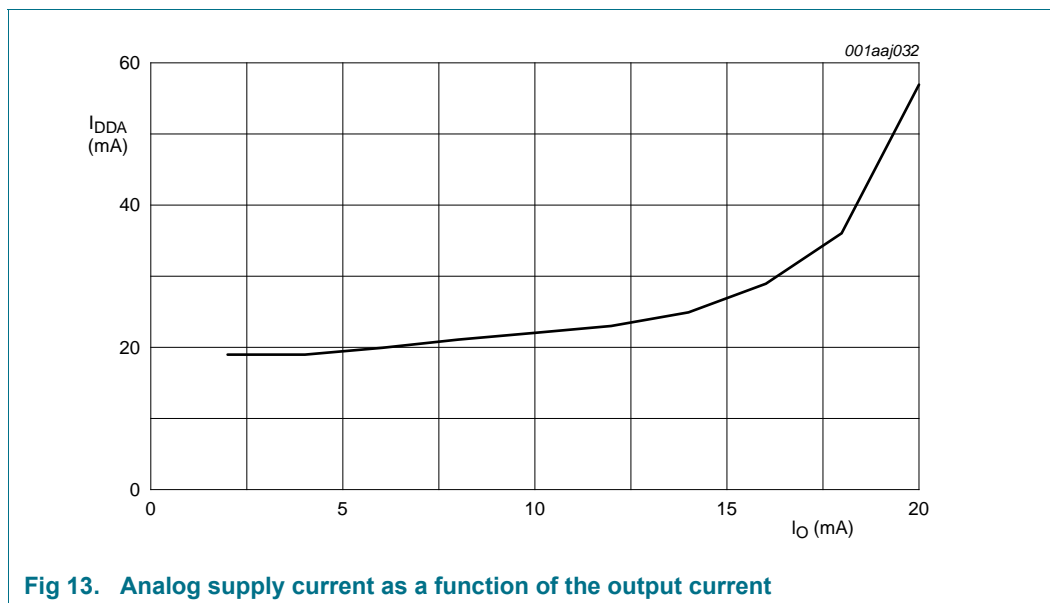

Fig 13. Analog supply current as a function of the output current

10. Application information

10.1 General description

The DAC1401D125 is a dual 14-bit DAC operating up to 125 Msp/s. Each DAC consists of a segmented architecture, comprising a 7-bit thermometer sub-DAC and a 7-bit binary weighted sub-DAC.

Two modes are available for the digital input depending on the status of the pin MODE. In Dual port mode, each DAC uses its own data input line at the same frequency as the update rate. In Interleaved mode, both DACs use the same data input line at twice the update rate.

Each DAC generates on pins IOUTAP/IOUTAN and IOUTBP/IOUTBN two complementary current outputs. This provides a full-scale output current ($I_{O(fs)}$), up to 20 mA. A single common or two independent full-scale current controls can be selected for both channels using pin GAINCTRL. An internal reference is available for the reference current which is externally adjustable using pin REFIO.

The DAC1401D125 operates at 3.3 V and has separate digital and analog power supplies. Pin PWD is used to power-down the device. The digital input is 1.8 V compliant, 3.3 V compliant and 5 V tolerant.

10.2 Input data

The DAC1401D125 input follows a straight binary coding where DA13 and DB13 are the Most Significant Bits (MSB) and DA0 and DB0 are the Least Significant Bits (LSB).

The setting applied to pin MODE defines whether the DAC1401D125 operates in Dual port mode or in Interleaved mode (see Table 6).

Table 6. Mode selection

Mode	Function	DA13 to DA0	DB13 to DB0	Pin 17	Pin 18	Pin 19	Pin 20
0	Interleaved mode	active	off	IQWRT	IQCLK	IQRESET	IQSEL
1	Dual port mode	active	active	WRTA	CLKA	CLKB	WRTB

10.2.1 Dual port mode

The data and clock circuit for Dual port mode operation is shown in Figure 14.

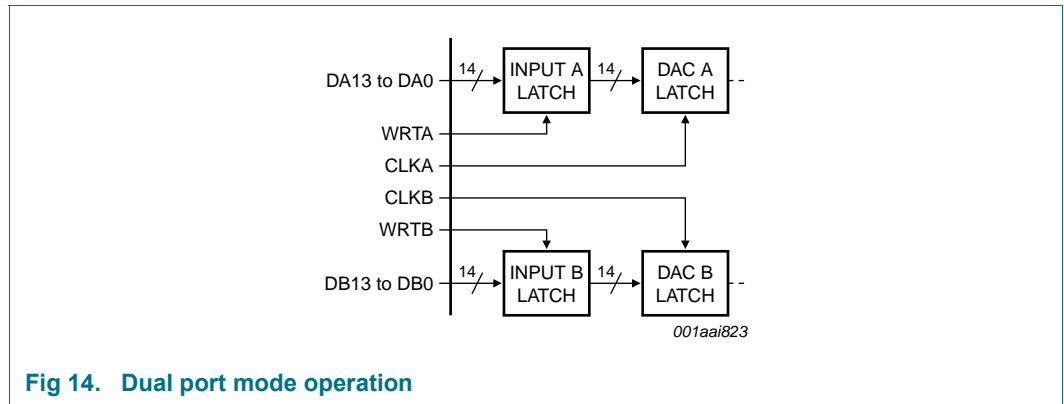

Fig 14. Dual port mode operation

Each DAC has its own independent data and clock inputs. The data enters the input latch on the rising edge of the WRTA/WRTB signal and is transferred to the DAC latch. The output is updated on the rising edge of the CLKA/CLKB signal.

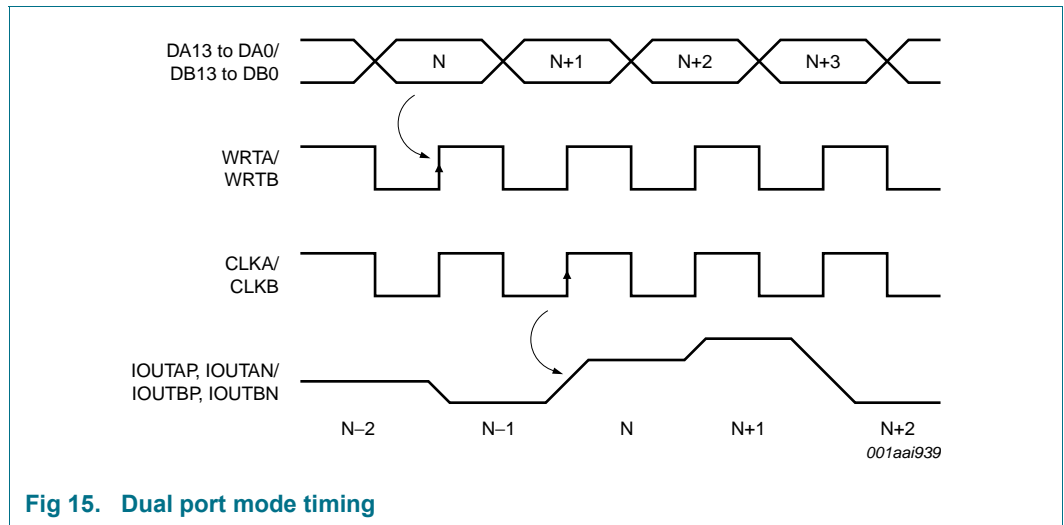

Fig 15. Dual port mode timing

10.2.2 Interleaved mode

The data and clock circuit for Interleaved mode operation is illustrated in Figure 16.

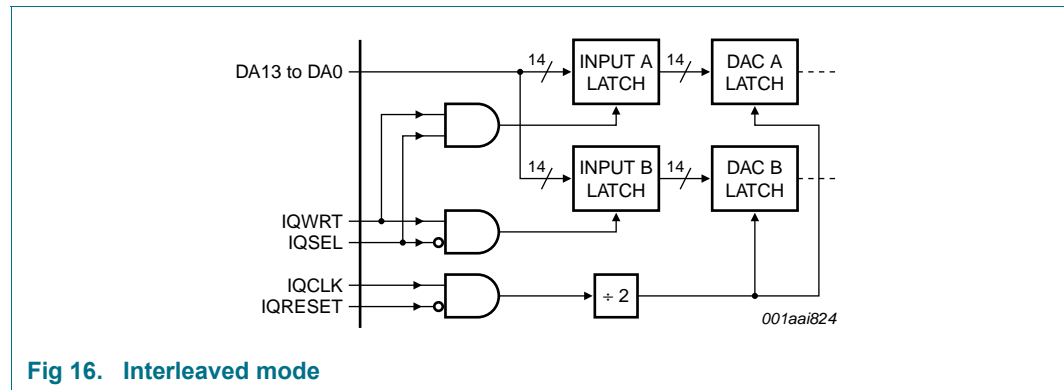

Fig 16. Interleaved mode

In Interleaved mode, both DACs use the same data and clock inputs at twice the update rate. Data enters the latch on the rising edge of IQWRT. The data is sent to either latch A or latch B, depending on the value of IQSEL. The IQSEL transition must occur when IQWRT and IQCLK are LOW.

The IQCLK is divided by 2 internally and the data is transferred to the DAC latch. It is updated on its rising edge. When IQRESET is HIGH, IQCLK is disabled, see Figure 17.

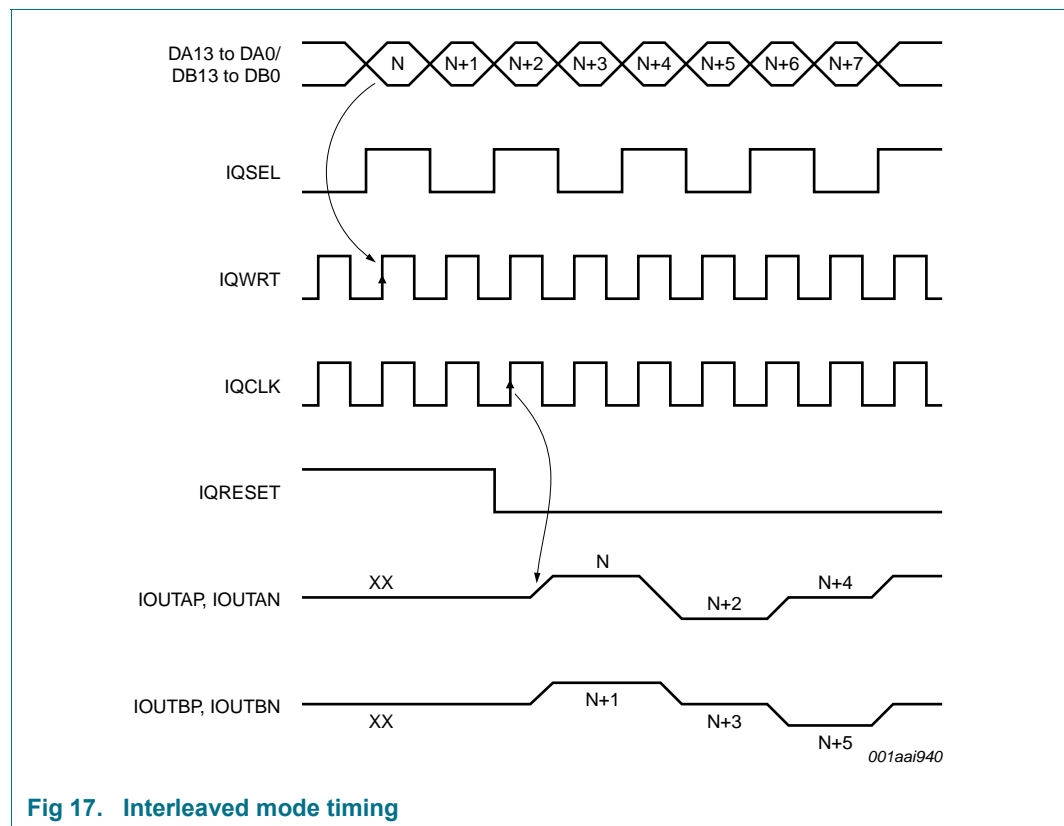

Fig 17. Interleaved mode timing

10.3 Timing

The DAC1401D125 can operate at an update rate up to 125 Mps. This generates an input data rate of 125 MHz in Dual port mode and 250 MHz in Interleaved mode. The timing of the DAC1401D125 is shown in Figure 18.

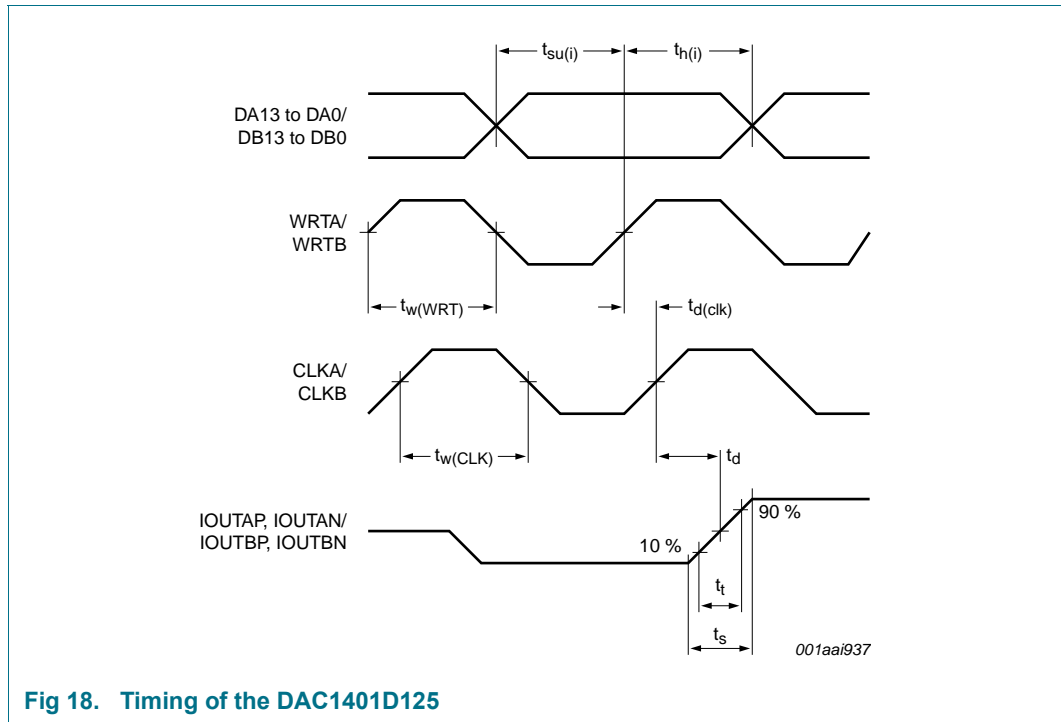

Fig 18. Timing of the DAC1401D125

The typical performances are measured at 50 % duty cycle but any timing within the limits of the characteristics will not alter the performance.

- A configuration resulting in the same timing for the signals WRTA/WRTB and CLKA/CLKB, can be achieved either by synchronizing them or by connecting them together.
- The rising edge of the CLKA/CLKB signal can also be placed in a range from half a period in front of the rising edge of the WRTA/WRTB signal to half a period minus 1 ns after the rising edge of the WRTA/WRTB signal.

A typical set-up time of 0 ns and a hold time of 0.6 ns enable the DAC1405D125 to be easily integrated into any application.

10.4 DAC transfer function

The full-scale output current for each DAC is the sum of the two complementary current outputs:

$$I_{O(fs)} = I_{IOUTP} + I_{IOUTN} \tag{1}$$

The output current depends on the digital input data:

$$I_{IOUTP} = I_{O(fs)} \times \left(\frac{DATA}{16384} \right) \quad I_{IOUTN} = I_{O(fs)} \times \left(\frac{(16383 - DATA)}{16384} \right)$$

Table 7 shows the output current as a function of the input data, when $I_{O(fs)} = 20 \text{ mA}$.

Table 7. DAC transfer function

Data	DA13/DB13 to DA0/DB0	IOUTAP/IOUTBP	IOUTAN/IOUTBN
0	00 0000 0000 0000	0 mA	20 mA
...
8192	10 0000 0000 0000	10 mA	10 mA
...
16383	11 1111 1111 1111	20 mA	0 mA

10.5 Full-scale current adjustment

The DAC1401D125 integrates one 1.25 V reference and two current sources to adjust the full-scale current in both DACs.

The internal reference configuration is shown in Figure 19.

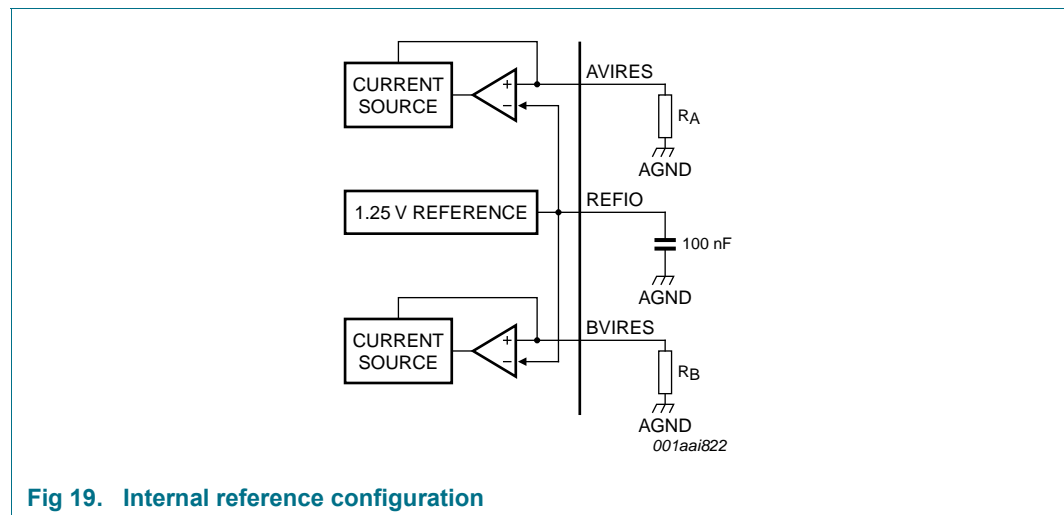

Fig 19. Internal reference configuration

The bias current is generated by the output of the internal regulator connected to the inverting input of the internal operational amplifiers. The external resistors R_A and R_B are connected to pins AVIRES and BVIRES, respectively. This configuration is optimal for temperature drift compensation because the bandgap can be matched with the voltage on the feedback resistors.

The relationship between full-scale output current ($I_{O(fs)}$) at the output of channel A or channel B and the resistor is:

$$I_{O(fs)} = \frac{24V_{REFIO}}{R_A} \tag{2}$$

The output current of the two DACs is typically fixed at 20 mA when both resistors R_A and R_B are set to 1.5 kΩ. The operational range of DAC1401D125 is from 2 mA to 20 mA.

It is recommended to decouple pin REFIO using a 100 nF capacitor.

An external reference can also be used for applications requiring higher accuracy or precise current adjustment. Due to the high input impedance of pin REFIO, applying an external source disables the bandgap.

10.6 Gain control

Table 8 shows how to select the different gain control modes.

Table 8. Gain control

GAINCTRL	Mode	DAC A full-scale control	DAC B full-scale control
0	independent gain control	AVIRES	BVIRES
1	common gain control	AVIRES	AVIRES

In Independent gain mode, both full-scale currents can be adjusted independently using resistors R_A on pin AVIRES and R_B on pin BVIRES.

In Common gain mode, the full-scale current is adjusted with resistor R_A on pin AVIRES and divided by two in both DACs.

10.7 Analog outputs

See Figure 20 for the analog output circuit of one DAC. This circuit consists of a parallel combination of PMOS current sources and associated switches for each segment.

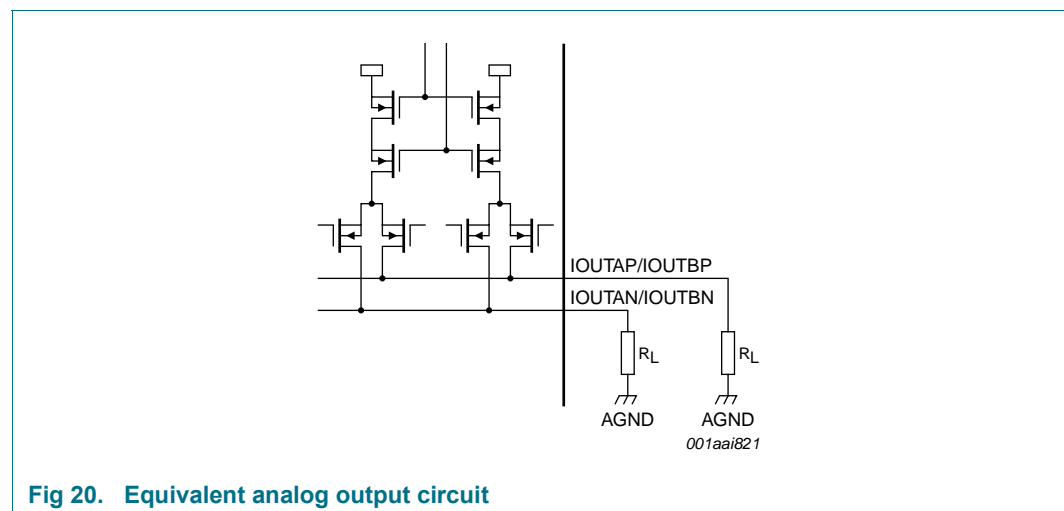

Fig 20. Equivalent analog output circuit

Cascode source configuration enables the output impedance of the source to be increased, thus improving the dynamic performance by reducing distortion.

The DAC1401D125 can be used either with:

- a differential output, coupled to a transformer (or operational amplifier) to reduce even-order harmonics and noise
- or a single-ended output for applications requiring unipolar voltage.

The typical configuration is to use 1 V p-p level on each output IOUTAP/IOUTBP and IOUTAN/IOUTBN but several combinations can be used as far as they respect the voltage compliance range.

10.7.1 Differential output using transformer

The use of a differentially coupled transformer output (see Figure 21) provides optimum distortion performance. In addition, it helps to match the impedance and provides electrical isolation.

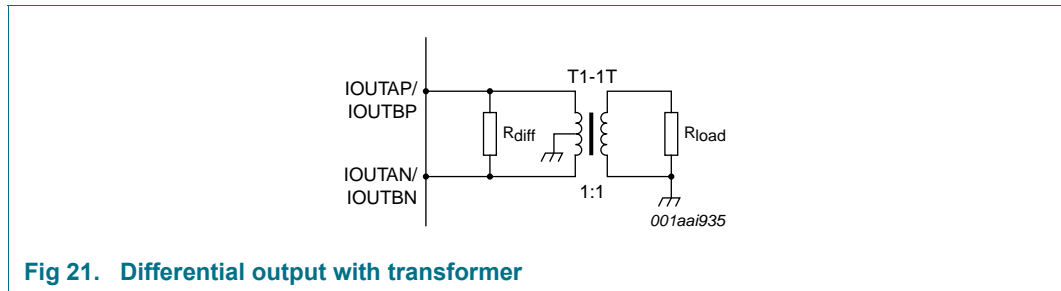

Fig 21. Differential output with transformer

The center tap is grounded to allow the DC current flow to/from both outputs. If the center tap is open, the differential resistor must be replaced by two resistors connected to ground.

10.7.2 Single-ended output

Using a single load resistor on one current output will provide an unipolar output range, typically from 0 V to 0.5 V with a 20 mA full-scale current at a 50 Ω load.

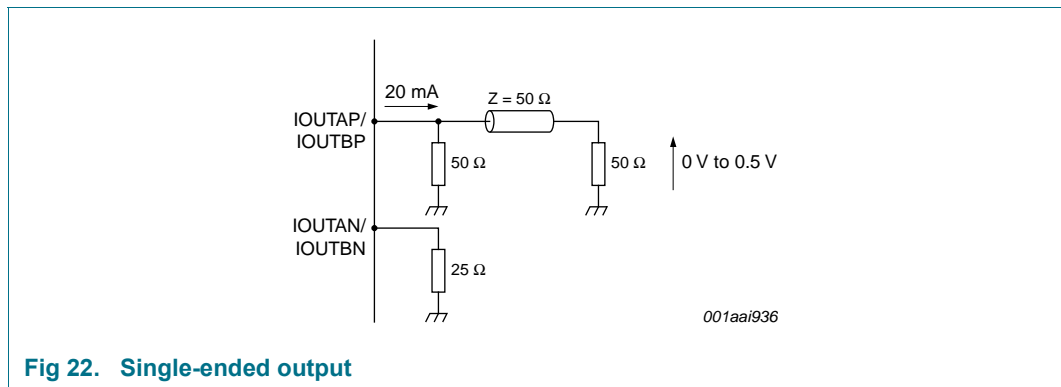

Fig 22. Single-ended output

The resistor on the other current output is 25 Ω.

10.8 Power-down function

The DAC1404D125 has a power-down function to reduce the power consumption when it is not active.

Table 9. Power-down

PWD	Device function	Power dissipation (typ)
0	active	185 mW
1	not active	16.5 mW

10.9 Alternative parts

The following alternative parts are also available.

Table 10. Alternative parts

Pin compatible

Type number	Description	Sampling frequency
DAC1001D125	dual 10-bit DAC	up to 125 Msps
DAC1201D125	dual 12-bit DAC	up to 125 Msps

10.10 Application diagram

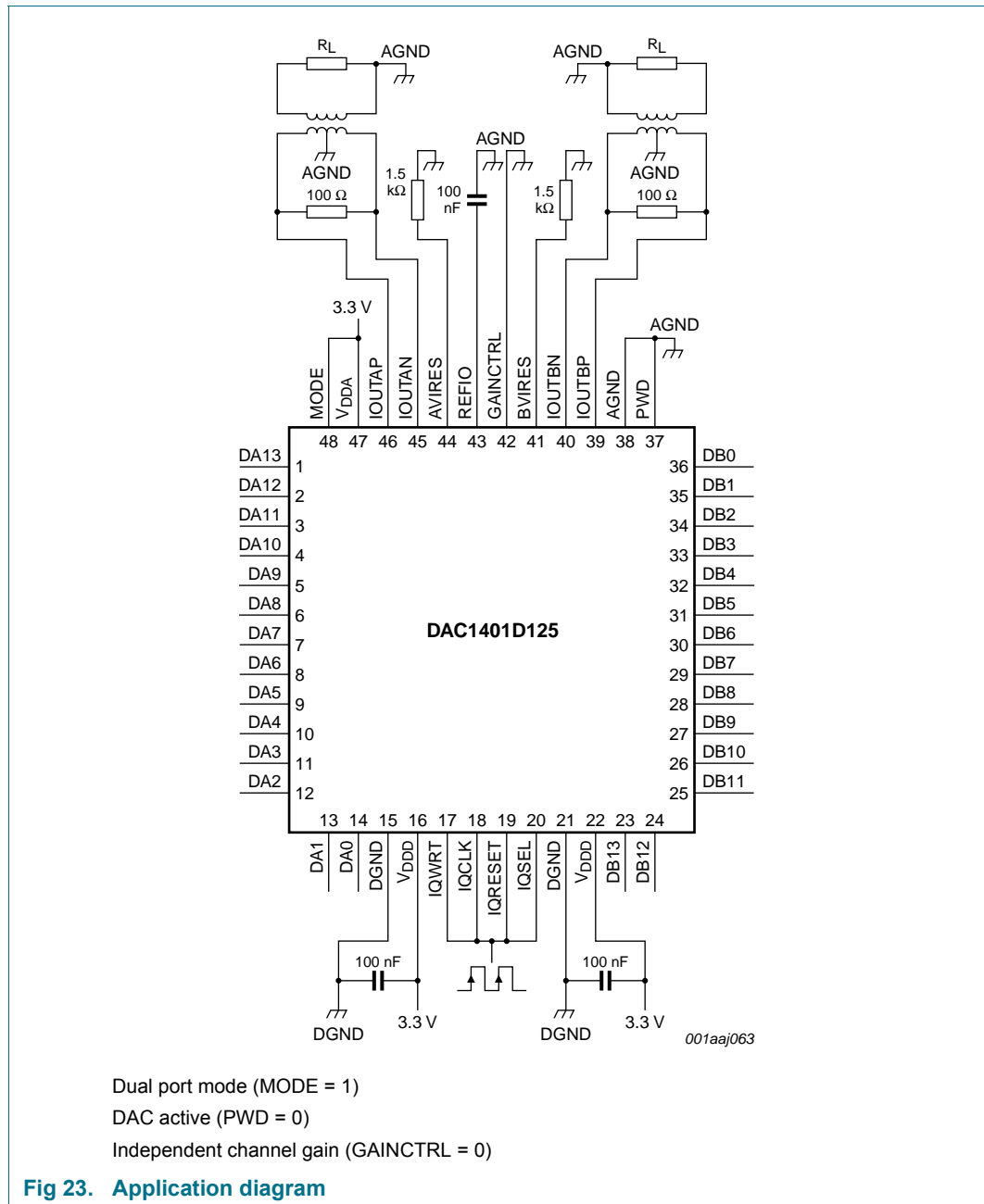

11. Package outline

LQFP48: plastic low profile quad flat package; 48 leads; body 7 x 7 x 1.4 mm

SOT313-2

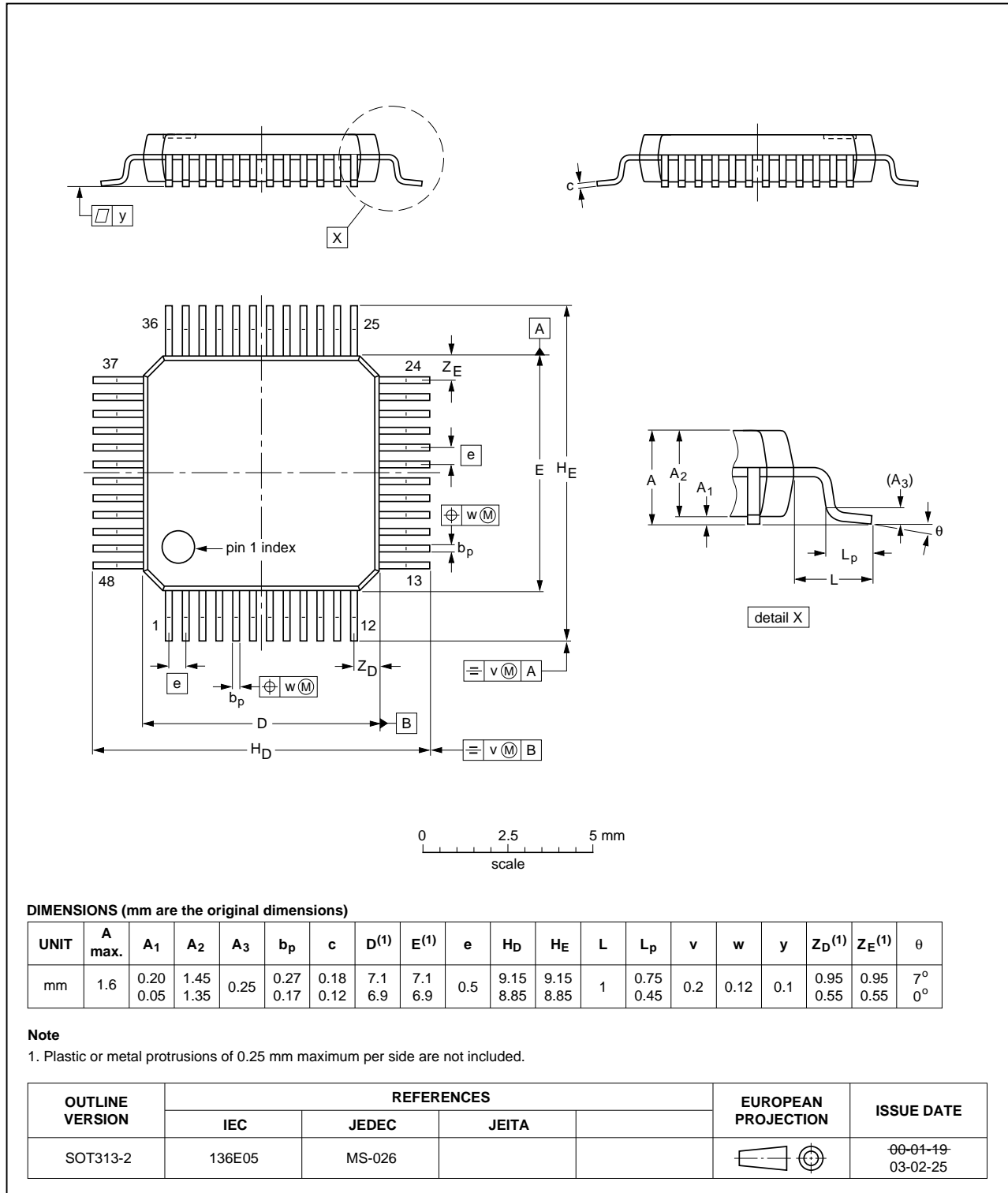

Fig 24. Package outline SOT313-2 (LQFP48)

12. Abbreviations

Table 11. Abbreviations

Acronym	Description
BW	BandWidth
DNL	Differential Non-Linearity
dBFS	deciBel Full-Scale
IF	Intermediate Frequency
INL	Integral Non-Linearity
LSB	Least Significant Bit
MSB	Most Significant Bit
PMOS	Positive-channel Metal-Oxide Semiconductor
SFDR	Spurious-Free Dynamic Range

13. Revision history

Table 12. Revision history

Document ID	Release date	Data sheet status	Change notice	Supersedes
DAC1401D125 v.3	20120702	Product data sheet	-	DAC1401D125 v.2
DAC1401D125 v.2	20120127	Product data sheet	-	DAC1401D125 v.1
Modifications:	<ul style="list-style-type: none">• Table 4 “Thermal characteristics” has been updated.• Section 10.6 “Gain control” has been updated.			
DAC1401D125 v.1	20081113	Product data sheet	-	-

14. Contact information

For more information or sales office addresses, please visit: <http://www.idt.com>

15. Contents

1	General description	1	10.2.2	Interleaved mode	16
2	Features and benefits	1	10.3	Timing	17
3	Applications	1	10.4	DAC transfer function	17
4	Ordering information	2	10.5	Full-scale current adjustment	18
5	Block diagram	2	10.6	Gain control	19
6	Pinning information	3	10.7	Analog outputs	19
6.1	Pinning	3	10.7.1	Differential output using transformer	20
6.2	Pin description	3	10.7.2	Single-ended output	20
7	Limiting values	5	10.8	Power-down function	20
8	Thermal characteristics	5	10.9	Alternative parts	21
9	Characteristics	5	10.10	Application diagram	21
10	Application information	14	11	Package outline	22
10.1	General description	14	12	Abbreviations	23
10.2	Input data	14	13	Revision history	24
10.2.1	Dual port mode	15	14	Contact information	24
			15	Contents	25