

THIS DRAWING IS UNPUBLISHED. RELEASED FOR PUBLICATION
 © COPYRIGHT - By - ALL RIGHTS RESERVED.

LOC	DIST	REVISIONS			
P	LTR	DESCRIPTION	DATE	DWN	APVD
AF	50	AB1	REVISED PER ECO-11-004820	11MAR11	RK HMR

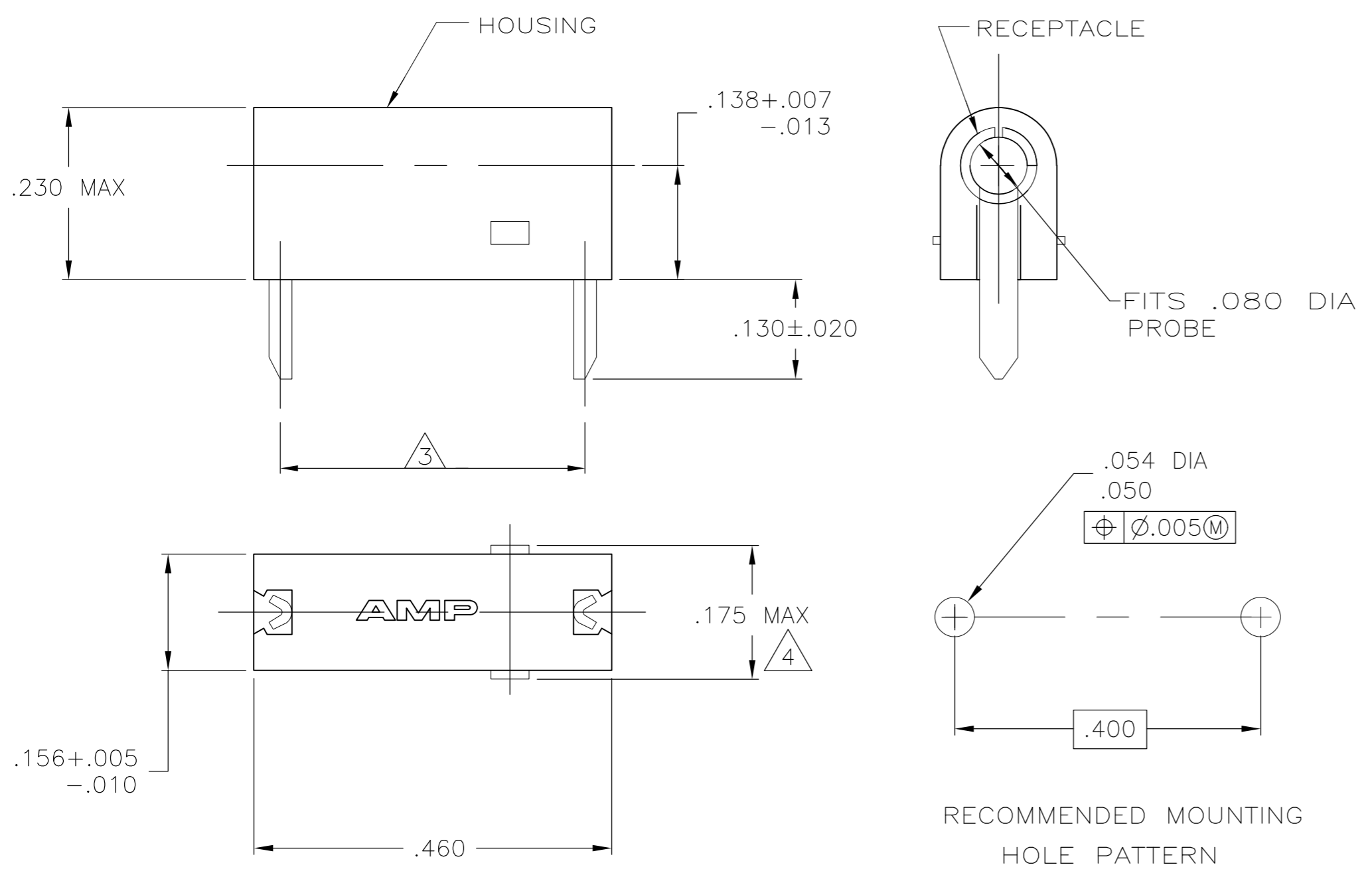

- 1 OPERATION TEMPERATURE IS 105° C MAX.
- 2 RETENTION FORCE - 16 OUNCES MIN INITIALLY.
6 OUNCES MIN AFTER 500 CYCLES.
- 3 REFER TO MOUNTING HOLE PATTERN.
- 4 .175 MAX TO BE MEASURED ACROSS THE CUT-OFF TABS.

OBSOLETE	NYLON 6/6; WHITE	BRASS - GOLD	3-582118-9
OBSOLETE	NYLON 6/6; GRAY	BRASS - GOLD	3-582118-8
	NYLON 6/6; VIOLET	BRASS - GOLD	3-582118-7
	NYLON 6/6; BLUE	BRASS - GOLD	3-582118-6
	NYLON 6/6; GREEN	BRASS - GOLD	3-582118-5
	NYLON 6/6; YELLOW	BRASS - GOLD	3-582118-4
	NYLON 6/6; ORANGE	BRASS - GOLD	3-582118-3
	NYLON 6/6; RED	BRASS - GOLD	3-582118-2
OBSOLETE	NYLON 6/6; BROWN	BRASS - GOLD	3-582118-1
	NYLON 6/6; BLACK	BRASS - GOLD	3-582118-0
	NYLON 6/6; WHITE	BRASS - SILVER	2-582118-9
OBSOLETE	NYLON 6/6; GRAY	BRASS - SILVER	2-582118-8
OBSOLETE	NYLON 6/6; VIOLET	BRASS - SILVER	2-582118-7
	NYLON 6/6; BLUE	BRASS - SILVER	2-582118-6
OBSOLETE	NYLON 6/6; GREEN	BRASS - SILVER	2-582118-5
OBSOLETE	NYLON 6/6; YELLOW	BRASS - SILVER	2-582118-4
OBSOLETE	NYLON 6/6; ORANGE	BRASS - SILVER	2-582118-3
	NYLON 6/6; RED	BRASS - SILVER	2-582118-2
OBSOLETE	NYLON 6/6; BROWN	BRASS - SILVER	2-582118-1
	NYLON 6/6; BLACK	BRASS - SILVER	2-582118-0
	NYLON 6/6; WHITE	BRASS - TIN	1-582118-9
OBSOLETE	NYLON 6/6; GRAY	BRASS - TIN	1-582118-8
OBSOLETE	NYLON 6/6; VIOLET	BRASS - TIN	1-582118-7
OBSOLETE	NYLON 6/6; BLUE	BRASS - TIN	1-582118-6
	NYLON 6/6; GREEN	BRASS - TIN	1-582118-5
	NYLON 6/6; YELLOW	BRASS - TIN	1-582118-4
OBSOLETE	NYLON 6/6; ORANGE	BRASS - TIN	1-582118-3
	NYLON 6/6; RED	BRASS - TIN	1-582118-2
OBSOLETE	NYLON 6/6; BROWN	BRASS - TIN	1-582118-1
	NYLON 6/6; BLACK	BRASS - TIN	1-582118-0

	-	-	-
	-	-	-
	-	-	-
	NYLON 6/6; NATURAL	BRASS - GOLD	6-582118-9
OBSOLETE	NYLON 6/6; NATURAL	BRASS - SILVER	5-582118-9
	HOUSING - MATERIAL; COLOR	RECEPTACLE - MATERIAL; FINISH	PART NUMBER

THIS DRAWING IS A CONTROLLED DOCUMENT. DWN M.S. FEHER 13APR2004
 CHK E. HOWARD 13APR2004
 APVD E. HOWARD 13APR2004

STE TE Connectivity

NAME ASSEMBLY, TEST PROBE

SIZE A2 CAGE CODE 00779 DRAWING NO C=582118 RESTRICTED TO -

SCALE 6:1 SHEET 1 OF 1 REV AB1

MATERIAL SEE TABLE FINISH SEE TABLE WEIGHT - APPLICATION SPEC -

DIMENSIONS: mm TOLERANCES UNLESS OTHERWISE SPECIFIED:
 0 PLC ± -
 1 PLC ± -
 2 PLC ± .015
 3 PLC ± -
 4 PLC ± -
 ANGLES ± -

CUSTOMER DRAWING