

RECOMMENDED MOUNTING HOLE PATTERN FOR 1.57[.062] THICK P.C. BOARD $\triangle 11$

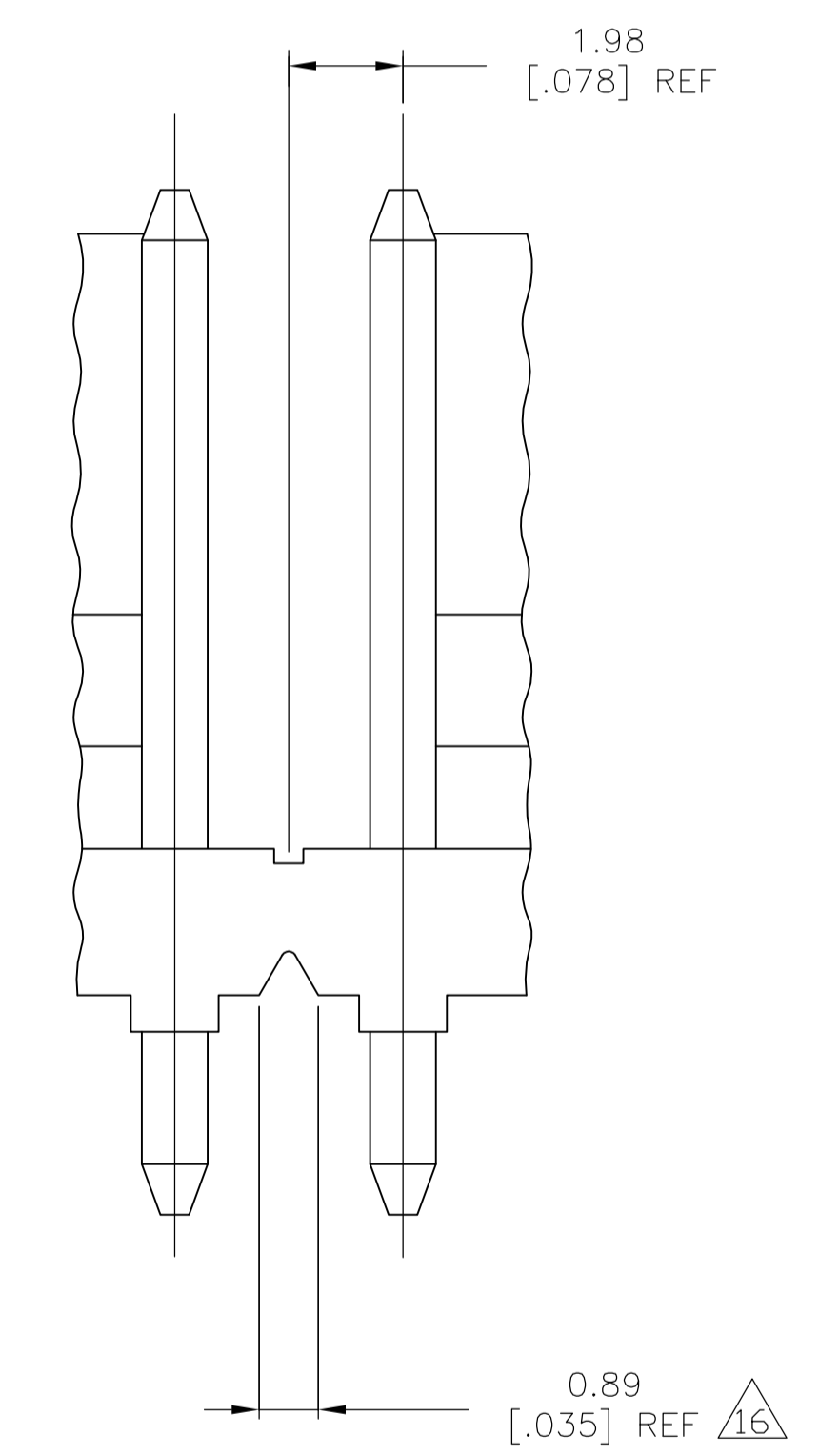

INTERRUPTED WALL FOR POSITION SIZES 6 AND ABOVE $\triangle 3$

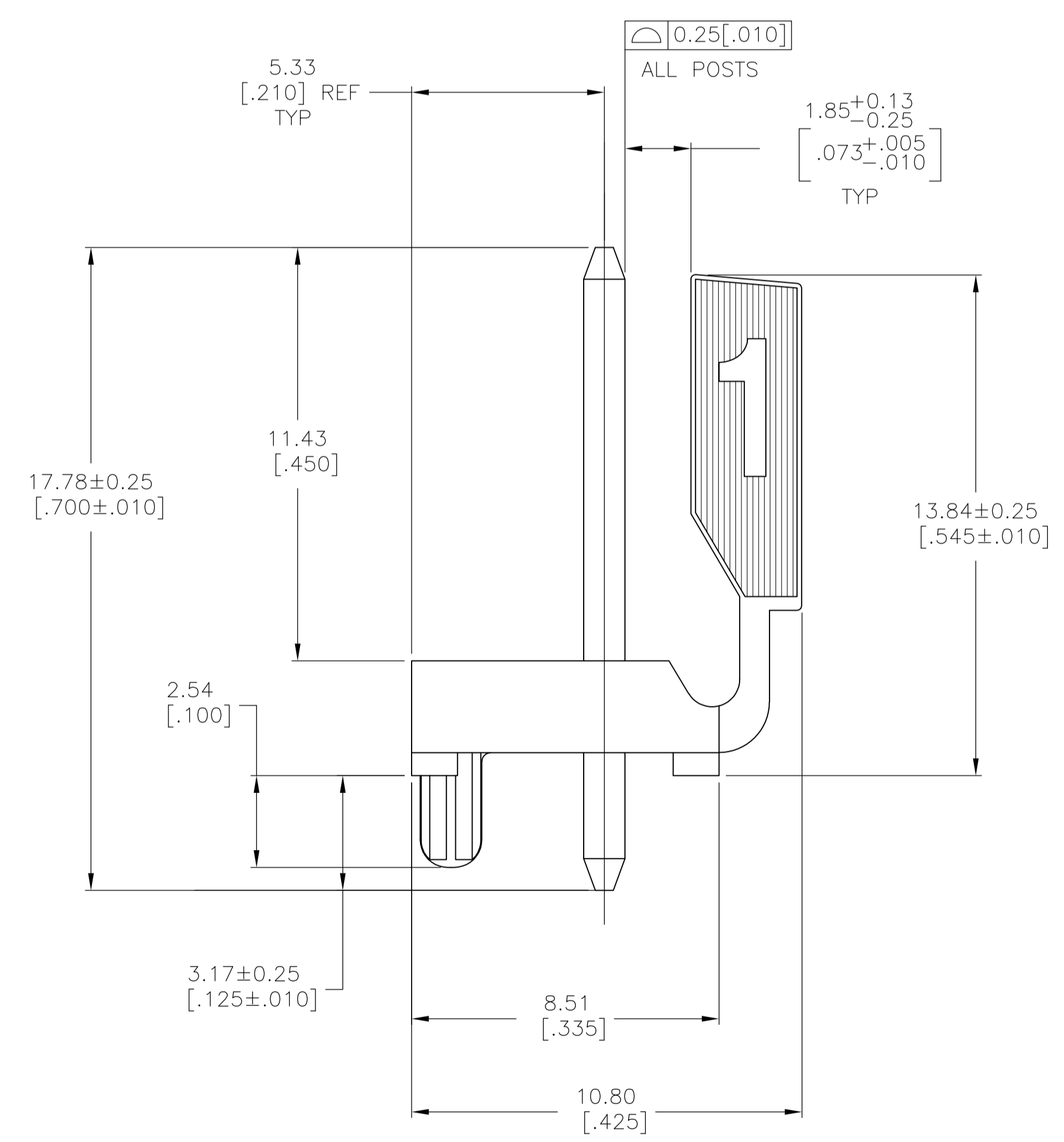
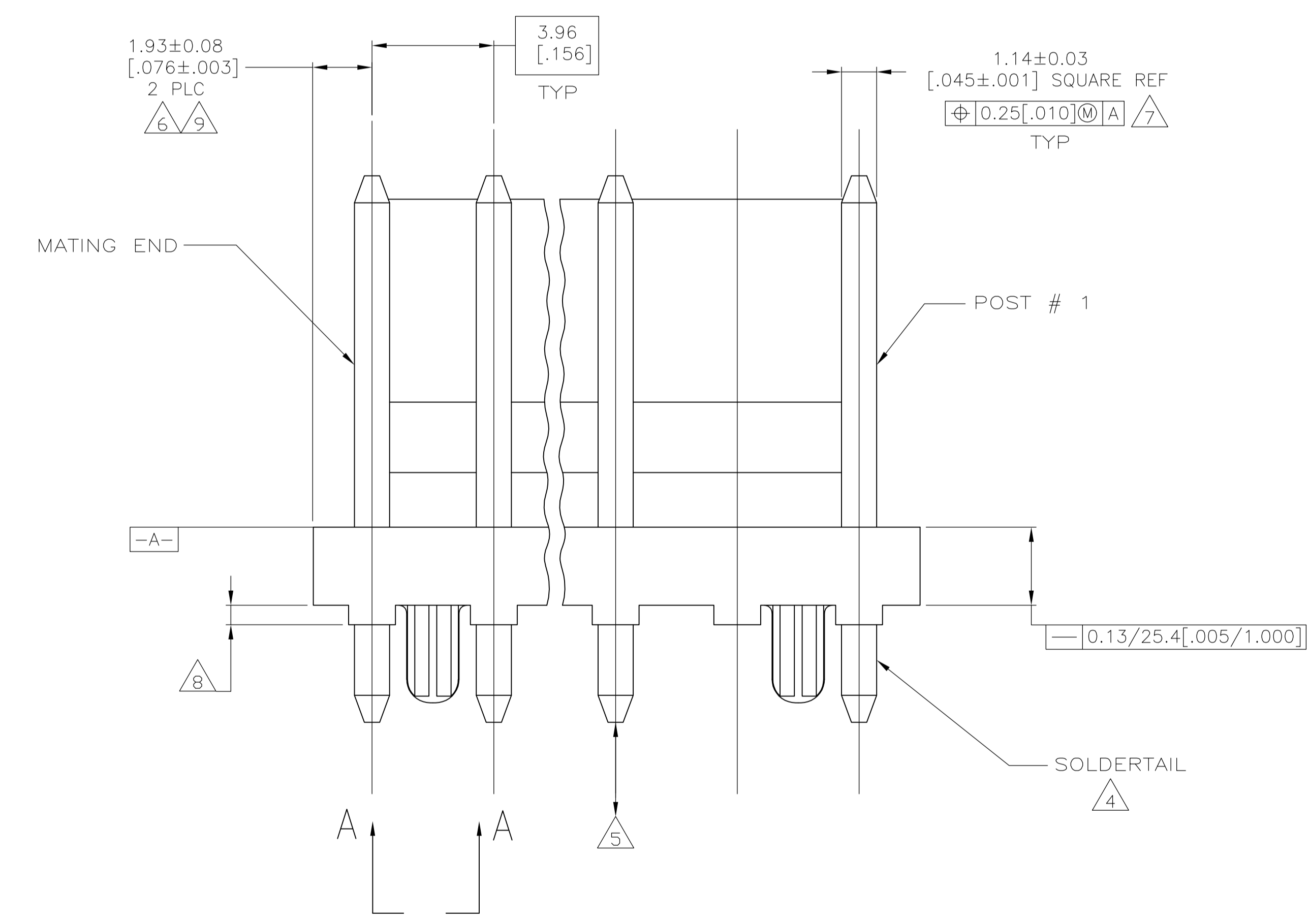
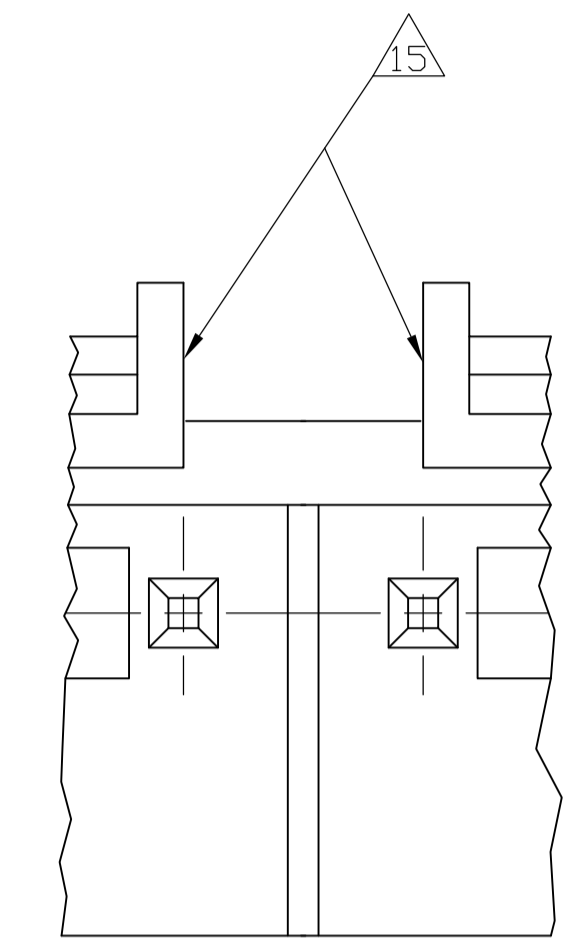
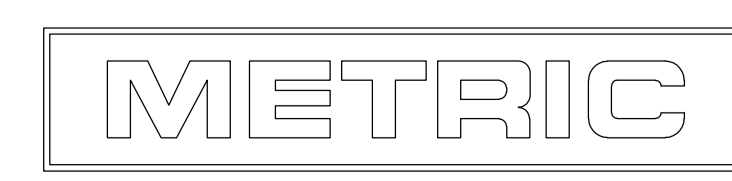

THIS DRAWING IS A CONTROLLED DOCUMENT.		DWN K. WHITAKER 02DEC03	TE Connectivity
DIMENSIONS: mm [INCHES]		CHK D. ROSSI 02DEC03	
TOLERANCES UNLESS OTHERWISE SPECIFIED:		NAME D. ROSSI 02DEC03	MTA-156 HEADER ASSEMBLY, POLARIZED LOCK, STRAIGHT .045 SQUARE POST, TIN-LEAD PLATED
0 PLC ± - 1 PLC ± - 2 PLC ± 0.13[.005] 3 PLC ± - 4 PLC ± - ANGLES ± -		PRODUCT SPEC	
MATERIAL		APPLICATION SPEC	RESTRICTED TO
FINISH		WEIGHT	SIZE A1
CUSTOMER DRAWING		SCALE 8:1	CAGE CODE 644661 DRAWING NO 00779 SHEET 1 OF 2 REV K2

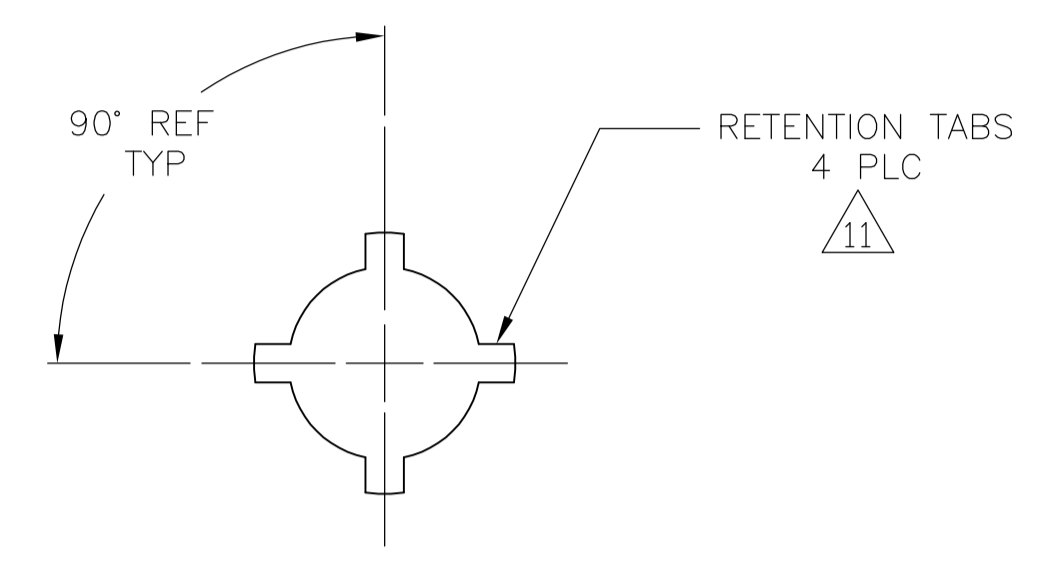

VIEW A-A
SCALE 10:1

- 1 MATERIAL:
HOUSING: THERMOPLASTIC POLYESTER, GLASS FILLED, UL94V-0.
POST: COPPER ALLOY
- 2 FINISH
HOUSING: NATURAL
POST: BRIGHT TIN-LEAD (93/7) OR MATTE TIN PLATE 0.00380(.000150) -0.00880(.000350) OVER NICKEL UNDERPLATE 0.0013(.000050) MIN THICK. SEE PLATING COLUMN FOR DETAILS.
- 3 ALL POSITION SIZES HAVE THE BACKWALL NOTCHED ON BOTH ENDS AS SHOWN. THE 2 AND 5 POSITION SIZES HAVE SOLID BACKWALLS. POSITION SIZES 6 AND ABOVE HAVE AN INTERRUPTED BACKWALL AT VARIOUS LOCATIONS. (SEE TABLE FOR INTERRUPTION(S) LOCATIONS).
- 4 POST SOLDER TAILS COMPLY WITH AMP SOLDERABILITY SPEC 109-11-2.
- 5 POST WITHSTANDS 13.34N (3 LB) MIN AXIAL FORCE IN EITHER DIRECTION WITHOUT DISLODGING.
- 6 APPLIES AT -A-
- 7 APPLIES WHEN THE HEADER IS STRAIGHT.
- 8 PLASTIC PROJECTIONS PERMITTED IN THIS ZONE.
- 9 COORDINATE DIMENSIONS APPLIES FROM THE CENTER OF THE ACTUAL FEATURE.
- 10 SOLDER SIDE OF BOARD IS SHOWN.
- 11 THE RETENTION TABS PROVIDE A ONE-TIME INTERFERENCE FIT IN THE 1.63[.064] DIAMETER BOARD HOLE FOR HEADER ASSEMBLY RETENTION DURING SOLDERING. FOUR TABS PER PEG, TWO PEGS PER HEADER ASSEMBLY (ONE PEG ONLY FOR 2 POSITION SIZE).
- 12 UL MARKING MAY NOT APPEAR ON THE 2 OR 3 POSITION SIZES. CSA MARKING MAY NOT APPEAR ON THE 2 POSITION SIZE.
- 13 POST NO. 2 OMITTED.
- 14. DIMENSIONS IN BRACKETS ARE IN INCHES
- 15 EDGE OF POLARIZING LOCK WALL TO BE IN LINE WITH CENTERLINE OF ADJACENT POST WITHIN ±0.13[.005].
- 16 NOTCH SHOWN MAY OR MAY NOT APPEAR.
- 17 OBSOLETE PART NUMBER

FINISH	BACKWALL INTERRUPTION(S) BETWEEN POST(S)	L	NO OF POSITIONS	PART NO
TIN	4,5	31.57 [1.243]	8	3-644661-8
TIN	3,4	23.65 [.931]	6	3-644661-6
TIN	NONE	15.72 [.619]	4	3-644661-4
TIN	NONE	11.76 [.463]	3	3-644661-3
17 TIN-LEAD	4,5	31.57 [1.243]	8	644661-8
17 TIN-LEAD	NONE	15.72 [.619]	4	644661-4
17 TIN-LEAD	NONE	11.76 [.463]	3	644661-3

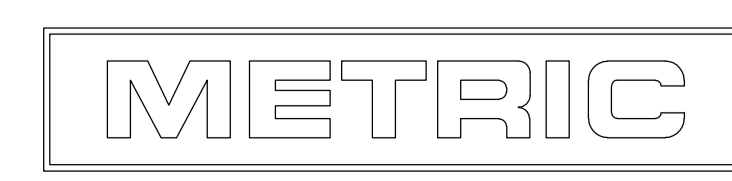

THIS DRAWING IS A CONTROLLED DOCUMENT.

DIMENSIONS: mm [INCHES]	TOLERANCES UNLESS OTHERWISE SPECIFIED:	0 PLC ± -	1 PLC ± -	2 PLC ± ± 0.13[.005]	3 PLC ± -	4 PLC ± -	ANGLES ± -
-------------------------	--	-----------	-----------	----------------------	-----------	-----------	------------

DRAWN: K. WHITAKER	02DEC03	TE Connectivity
CHK: D. ROSSI	02DEC03	
APVD: D. ROSSI	02DEC03	NAME: MTA-156 HEADER ASSEMBLY, POLARIZED LOCK, STRAIGHT .045 SQUARE POST, TIN-LEAD PLATED
MATERIAL: 1	FINISH: 2	SIZE: A1
CUSTOMER DRAWING		SCALE: 1:1

WEIGHT: -

SIZE: A1

DRAWING NO: 00779

REVISIONS: 644661

SHEET 2 OF 2

REV K2