

# High Voltage IGBT with Diode Electrically Isolated Tab

## IXGR 16N170AH1

$$\begin{aligned}
 V_{CES} &= 1700 \text{ V} \\
 I_{C25} &= 16 \text{ A} \\
 V_{CE(sat)} &= 5.0 \text{ V} \\
 t_{fi(typ)} &= 40 \text{ ns}
 \end{aligned}$$

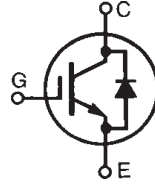

Symbol	Test Conditions	Maximum Ratings	
$V_{CES}$	$T_J = 25^\circ\text{C}$ to $150^\circ\text{C}$	1700	V
$V_{CGR}$	$T_J = 25^\circ\text{C}$ to $150^\circ\text{C}$ ; $R_{GE} = 1 \text{ M}\Omega$	1700	V
$V_{GES}$	Continuous	$\pm 20$	V
$V_{GEM}$	Transient	$\pm 30$	V
$I_{C25}$	$T_C = 25^\circ\text{C}$	16	A
$I_{C90}$	$T_C = 90^\circ\text{C}$	8	A
$I_{F90}$		15	A
$I_{CM}$	$T_C = 25^\circ\text{C}$ , 1 ms	40	A
<b>SSOA (RBSOA)</b>	$V_{GE} = 15 \text{ V}$ , $T_{VJ} = 125^\circ\text{C}$ , $R_G = 10 \Omega$ Clamped inductive load	$I_{CM} = 40$ @ $0.8 V_{CES}$	A
$t_{sc}$	$T_J = 125^\circ\text{C}$ , $V_{CE} = 1200 \text{ V}$ ; $V_{GE} = 15 \text{ V}$ , $R_G = 22 \Omega$	10	$\mu\text{s}$
$P_C$	$T_C = 25^\circ\text{C}$	120	W
$V_{ISOL}$	50/60 Hz, rms, 1 minute	2500	~V
$T_J$		-55 ... +150	$^\circ\text{C}$
$T_{JM}$		150	$^\circ\text{C}$
$T_{stg}$		-55 ... +150	$^\circ\text{C}$
$F_C$	Mounting force	22...130/5.30	N/lb
Maximum lead temperature for soldering 1.6 mm (0.062 in.) from case for 10 s		300	$^\circ\text{C}$
<b>Weight</b>		5	g

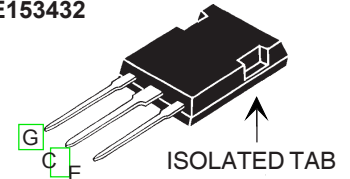
 ISOPLUS247 (IXGR)  
E153432

 G = Gate,  
E = Emitter

C = Collector,



### Features

- Electrically isolated tab
- International standard package outline
- High current handling capability
- MOS Gate turn-on  
- drive simplicity
- Rugged NPT structure
- UL recognized
- Molding epoxies meet UL 94 V-0 flammability classification
- SONIC-FRD™ fast recovery copack diode

### Applications

- Capacitor discharge & pulser circuits
- AC motor speed control
- DC servo and robot drives
- DC choppers
- Uninterruptible power supplies (UPS)
- Switched-mode and resonant-mode power supplies

Symbol	Test Conditions	Characteristic Values ( $T_J = 25^\circ\text{C}$ , unless otherwise specified)		
		min.	typ.	max.
$BV_{CES}$	$I_C = 250 \mu\text{A}$ , $V_{GE} = 0 \text{ V}$	1700		V
$V_{GE(th)}$	$I_C = 250 \mu\text{A}$ , $V_{CE} = V_{GE}$	3.0		V
$I_{CES}$	$V_{CE} = 0.8 \cdot V_{CES}$ $V_{GE} = 0 \text{ V}$		$T_J = 25^\circ\text{C}$ Note 1 $T_J = 125^\circ\text{C}$	100 $\mu\text{A}$ 1.5 mA
$I_{GES}$	$V_{CE} = 0 \text{ V}$ , $V_{GE} = \pm 20 \text{ V}$			$\pm 100 \text{ nA}$
$V_{CE(sat)}$	$I_C = I_{C90}$ , $V_{GE} = 15 \text{ V}$	$T_J = 25^\circ\text{C}$ $T_J = 125^\circ\text{C}$	4.2 4.8	V V

Symbol	Test Conditions	Characteristic Values ( $T_J = 25^\circ\text{C}$ , unless otherwise specified)		
		min.	typ.	max.
$g_{fs}$	$I_C = I_{C25}; V_{CE} = 10\text{ V}$ Note 2	6	10	S
$C_{ies}$	$V_{CE} = 25\text{ V}, V_{GE} = 0\text{ V}, f = 1\text{ MHz}$		1700	pF
$C_{oes}$			125	pF
$C_{res}$			30	pF
$Q_g$	$I_C = I_{C90}, V_{GE} = 15\text{ V}, V_{CE} = 0.5 V_{CES}$		65	nC
$Q_{ge}$			13	nC
$Q_{gc}$			24	nC
$t_{d(on)}$	<b>Inductive load, <math>T_J = 25^\circ\text{C}</math></b> $I_C = I_{C25}, V_{GE} = 15\text{ V}$ $R_G = 10\ \Omega, V_{CE} = 0.5 V_{CES}$ Note 3		36	ns
$t_{ri}$			57	ns
$t_{d(off)}$			200	350 ns
$t_{fi}$			40	150 ns
$E_{off}$			0.9	1.5 mJ
$t_{d(on)}$	<b>Inductive load, <math>T_J = 125^\circ\text{C}</math></b> $I_C = I_{C25}, V_{GE} = 15\text{ V}$ $R_G = 10\ \Omega, V_{CE} = 0.5 V_{CES}$ Note 3		38	ns
$t_{ri}$			59	ns
$E_{on}$			1.5	mJ
$t_{d(off)}$			200	ns
$t_{fi}$			55	ns
$E_{off}$			1.1	mJ
$R_{thJC}$				1.04 K/W
$R_{thCK}$		0.15		K/W

### ISOPLUS247 Outline

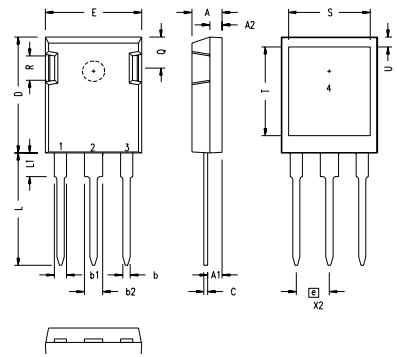

SYM	INCHES		MILLIMETERS	
	MIN	MAX	MIN	MAX
A	.190	.205	4.83	5.21
A1	.090	.100	2.29	2.54
A2	.075	.085	1.91	2.16
b	.045	.055	1.14	1.40
b1	.075	.084	1.91	2.13
b2	.115	.123	2.92	3.12
C	.024	.031	0.61	0.80
D	.819	.840	20.80	21.34
E	.620	.635	15.75	16.13
e	.215 BSC		5.45 BSC	
L	.780	.800	19.81	20.32
L1	.150	.170	3.81	4.32
Q	.220	.244	5.59	6.20
R	.170	.190	4.32	4.83
S	.520	.540	13.21	13.72
T	.620	.640	15.75	16.26
U	.065	.080	1.65	2.03

- 1 - GATE
- 2 - DRAIN (COLLECTOR)
- 3 - SOURCE (EMITTER)
- 4 - NO CONNECTION

NOTE: This drawing will meet all dimensions requirement of JEDEC outline TO-247AD except screw hole.

Symbol	Test Conditions	Characteristic Values ( $T_J = 25^\circ\text{C}$ , unless otherwise specified)		
		min.	typ.	max.
$V_F$	$I_F = 20\text{ A}, V_{GE} = 0\text{ V}$ , Note 2			2.7 V
$I_{RM}$	$I_F = 50\text{ A}, V_{GE} = 0\text{ V}, -di_F/dt = 800\text{ A}/\mu\text{s}$ $V_R = 600\text{ V}$		50	A
$t_{rr}$			150	ns
$R_{thJC}$				1.5 K/W

- Notes: 1. Device must be heatsunk for high temperature leakage current measurements to avoid thermal runaway.  
 2. Pulse test,  $t \leq 300\ \mu\text{s}$ , duty cycle  $\leq 2\%$   
 3. Switching times may increase for  $V_{CE}(\text{Clamp}) > 0.8 \cdot V_{CES}$ , higher  $T_J$  or increased  $R_G$ .

IXYS reserves the right to change limits, test conditions, and dimensions.

IXYS MOSFETs and IGBTs are covered by one or more of the following U.S. patents:	4,835,592	4,931,844	5,049,961	5,237,481	6,162,665	6,404,065B1	6,683,344	6,727,585
	4,850,072	5,017,508	5,063,307	5,381,025	6,259,123B1	6,534,343	6,710,405B2	6,759,692
	4,881,106	5,034,796	5,187,117	5,486,715	6,306,728 B1	6,583,505	6,710,463	