



Optical Encoders

SERIES 61B 16, 24, or 32 Position, Optional Pushbutton

FEATURES

- Positions Screen Cursor
- More Friendly than Keyboards
- Permits Visual Concentration
- Economic Touchscreen Alternative
- Pushbutton for Entry Function
- Detent for Tactile Feedback and Minimal Backlash
- Optical Coupled for Long Life
- Rugged Construction



APPLICATIONS

Display Input

The Series 61 rotary encoder switch can move cursor or icon on a display. Use the rotary and pushbutton switch to simply select a menu item and enter it, or write more elaborate display software. Use the Series 61 to input limit settings for a monitored function. Change an item on a checklist to a new value while viewing the remainder of the list.

Incremental Input

Use the Series 61 with an interface chip to provide step by step input for setting radio frequency, drill depth, RPM, etc. These changes are usually a few steps, and you need not turn the switch several revolutions for the desired value. Some examples are as follows:

- Robot Position
- Volume Setting
- Radio Tuning
- Limit Setting
- Motor Control

Suggested Mounting Panel Cutout

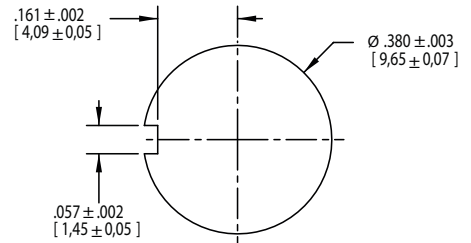

DIMENSIONS In inches (and millimeters)

Diagram illustrates a 16-position switch with integral pushbutton switch.

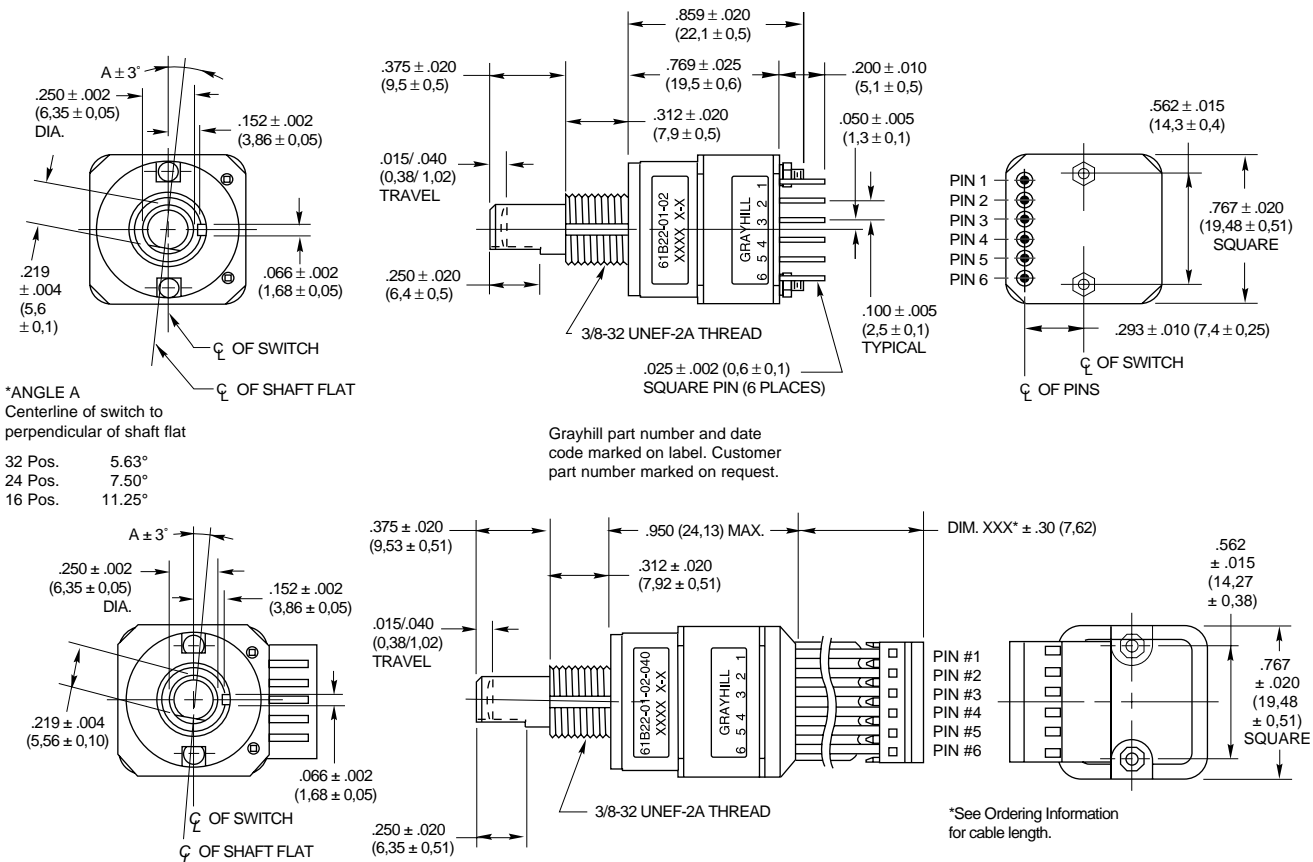

Unless otherwise indicated, tolerances are ± .010 (0.25).

SPECIFICATIONS

Pushbutton Switch Ratings

Rating: 5 Vdc, 10 mA, Resistive

Contact Resistance: less than 10 (TTL or CMOS Compatible)

Voltage Breakdown: 250 Vac between mutually insulated parts.

Contact Bounce: Less than 4 milliseconds at make and less than 10 milliseconds at break

Actuation Life: 3,000,000 operations

Actuation Force: Maximum actuation force of 615 grams and a minimum actuation force of 415 grams.

Encoder Ratings

Coding: 2-bit quadrature coded output

Operating Voltage: $5 \pm .25$ Vdc

Supply Current: 30 mA maximum at 5 Vdc

Logic High: 3.8V minimum

Logic Low: 0.8V maximum

Logic Rise and Fall Times: Rise Time less than 30 mS at 16.6 RPM. Fall Time less than 30 mS at 16.6 RPM.

Operating Torque: $2.0 \pm .75$ in-oz

Rotational Life: more than 1,000,000 cycles of operation (1 cycle = 360° rotation and return)

Shaft Push Out Force: 50 lbs minimum

Mounting Torque: 15 in-lbs maximum

Environmental Ratings

Operating Temperature Range: -40°C to 85°C

Storage Temperature Range: -55°C to 100°C

Vibration Resistance: Harmonic motion with amplitude of 15g, within a varied 10 to 2000 Hz frequency for 12 hours per MIL-STD-202, Method 204

Shock Resistance: Test 1: 100g for 6 mS half sine wave with velocity change of 12.3 ft/s. Test 2: 100g for 6 mS, sawtooth wave with velocity change of 9.7 ft/s.

Relative Humidity: 90–95% at 40°C for 96 hours

Materials and Finishes

Bushing: Zinc casting, cadmium-plated per QQP-416, Class 2, Type II

Shaft: Reinforced thermoplastic *Note: Earlier versions may have electropolished stainless steel shafts (still available in customs only).*

Mounting Hardware: One brass, cadmium-plated nut and lockwasher supplied with each switch. Nut is 0.094" thick by 0.562" across flats.

Cable: 26 AWG, stranded/tinned wire, PVC coated on .100 (2,54) centers (cable version only)

CIRCUITRY, TRUTH TABLE, AND WAVEFORM: Standard Quadrature 2-Bit Code

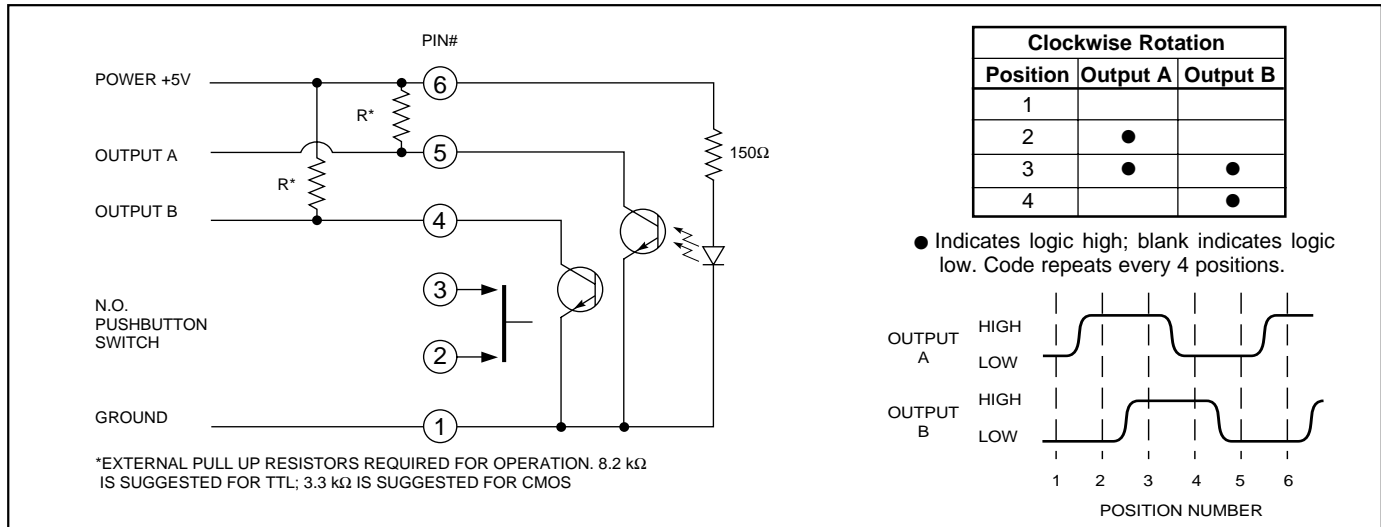

ORDERING INFORMATION

Series
Style: B = Standard, unsealed
Angle of Throw: 11 = 11.25° or 32 Positions
 15 = 15° or 24 Positions
 22 = 22.25° or 16 Positions
Coding: 01 = Quadrature
Pushbutton Option: 01 = Without pushbutton, 02 = With pushbutton

61B11-01-02-020

Termination: Blank (no dash or numbers) = pins as described in drawing
 Cable Termination 020 = 2.0 inches minimum to 250 = 25 inches maximum. Provided in increments of 1/2 inch. Example 035 = 3.5", 060 = 6 inches. Cable is terminated with standard Amp Connector 640442-6. Use any 6 position, .100 center header to mate with the cable assembly. Contact Grayhill

Custom shaft and bushing lengths, shaft/panel seal, and additional supply voltages are available through Grayhill only. Control knobs available, see page I-57.

Available from your local Grayhill Distributor. For prices and discounts, contact a local Sales Office, an authorized local Distributor or Grayhill.

ACCESSORIES

See page I-41.



Optical Encoder Engineering Information

QUADRATURE

All Grayhill encoders use quadrature output code, which is the same as a 2-bit, repeating gray code. Quadrature is the most popular and cost effective output format because only two detectors are required. However, quadrature can only be used in applications where incremental data is required. Absolute positioning is not possible because the code repeats every four positions. In other words, changes in the encoder in magnitude and direction can be determined, but the actual position of the encoder cannot. In most applications this is not a problem.

In a quadrature rotary optical encoder two detectors are used to provide outputs, "A" and "B". The code rotor either blocks the infrared light or allows it to pass to the detectors. As the shaft turns the rotor, the outputs change state to indicate position. The resulting output is two square waves which are 90° out of phase.

OPEN COLLECTOR OUTPUT

The open collector output is typical of the Series 61B, 61C and 62, and is the simplest form of output available. The first step in interfacing with open collector outputs is to provide an external pull-up resistor from each output to the power source. These pull-up

resistors provide the output with the high-state voltage when the phototransistor is "off".

In a phototransistor, base current is supplied when light strikes the detector, which effectively grounds the output. Typically, the detector is operated in saturation. This means sufficient light is provided to completely sink, or ground, all the current provided by the pull up resistor plus that of the interfacing electronics. In the logic high state, the light is sufficiently blocked by the rotor and the detector functions like an open circuit. The pull up resistor then provides sourcing current to the interfacing electronics. This "on" or "off" digital arrangement allows the open collector to interface with popular integrated circuit technologies such as TTL, TTL LS, CMOS, and HCMOS.

SCHMITT TRIGGERS

To provide signal enhancement it is recommended that a Schmitt Trigger be connected to each output. This device is already included in the Series 61K, 61R, 63K and 63R encoders. The Schmitt Trigger "cleans up" the output into a pure digital signal. It does this by removing the small linear region between the "on" and "off" states of the detector. During this transition the light is only partially blocked and the output is somewhere between what the interfacing circuit might con-

sider to be "on" or "off". In other words, the output is not completely digital. The Schmitt Trigger contains a very important feature which makes it attractive for this application. The device has a higher threshold, or trigger level, when it is in the "on" state than it does in the "off" state. This hysteresis filters any electrical noise, which can cause the output to change state rapidly during the transition. And since the output from the Schmitt Trigger is a pure digital signal and is isolated from the phototransistor, the signal is basically immune to loading problems that can effect encoders without the Schmitt Trigger. Schmitt Triggers are available in most popular IC technologies.

SHAFT AND PANEL SEAL

A shaft and panel seal are available to provide water-tight mounting for the Series 61B, 61D, 61K, 61R and 62 encoders. Sealing is accomplished by an o-ring shaft seal and a panel seal washer. The panel seal washer in the 61B and 61D encoders does not affect the overall dimensions of the switches. In the 61K and 61R encoders, the .045" thick washer is placed over the threads and sits flat on the base of the bushing. The 61KS and 61RS are also epoxy-sealed on the bottom of the switch to provide a completely sealed switch.

