

Quad Line Receiver

ELECTRICAL CHARACTERISTICS

Characteristic	Symbol	-30°C		+25°C		+85°C		Unit
		Min	Max	Min	Max	Min	Max	
Power Supply Drain Current	I_E	—	—	—	50	—	—	mAdc
Input Current	I_{in}	—	—	—	250	—	—	μ Adc
Input Leakage Current	I_R	—	—	—	100	—	—	μ Adc
Reference Voltage	V_{BB}	-1.375	-1.275	-1.35	-1.25	-1.3	-1.2	Vdc
Switching Times Propagation Delay	t^{-+}	0.6	1.6	0.6	1.5	0.6	1.7	ns
	t^{+-}	0.6	1.8	0.6	1.7	0.6	1.9	
Rise Time, Fall Time (10% to 90%)	t^+, t^-	0.6	2.2	0.6	2.1	0.6	2.3	ns

MC1692



L SUFFIX
CERAMIC PACKAGE
CASE 620-10

LOGIC DIAGRAM

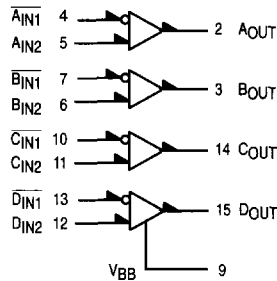

V_{CC1} = PIN 1
 V_{CC2} = PIN 16
 V_{EE} = PIN 8

t_{pd} = 0.9 ns typ (510 ohm load)
= 1.1 ns typ (50 ohm load)

P_D = 220 mW typ/pkg (No Load)
Full Load Current, I_L = -25 mAdc max

PIN ASSIGNMENT

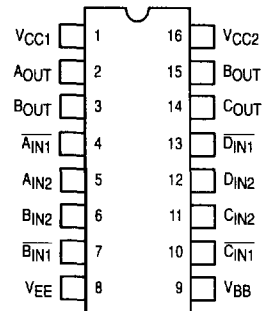

4



APPLICATION INFORMATION

The MC1692 quad line receiver is used primarily to receive data from balanced twisted pair lines, as indicated in Figure 1. The line is driven with a MC1660 OR/NOR gate. The MC1660 is terminated with 50 ohm resistors to -2.0 volts. At the end of the twisted pair a 100 ohm termination resistor is placed across the differential line receiver inputs of the MC1692. Illustrated in Figure 2 is the sending and receiving waveforms at a data rate of 400 megabits per second over an 18 foot twisted pair cable.

The waveform picture of Figure 3 shows a 5.0 nanosecond pulse being propagated down the 18 foot line. The delay time for the line is 1.68 ns/foot.

The MC1692 may also be applied as a high frequency schmitt trigger as illustrated in Figure 4. This circuit has been used in excess of 200 MHz. The MC1692 when loaded into 50 ohms will produce an output rising edge of about 1.5 nanoseconds.

FIGURE 1 — LINE DRIVER/RECEIVER

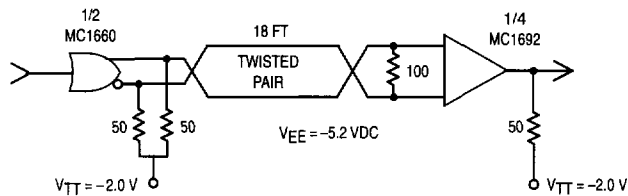

FIGURE 2 — 400 MBS WAVEFORMS

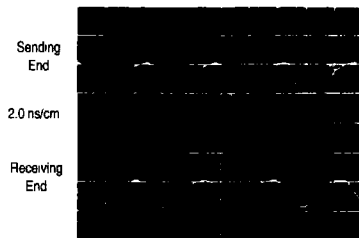

FIGURE 3 — PULSE PROPAGATION WAVEFORMS

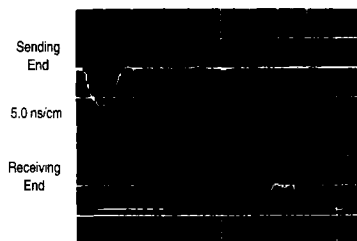
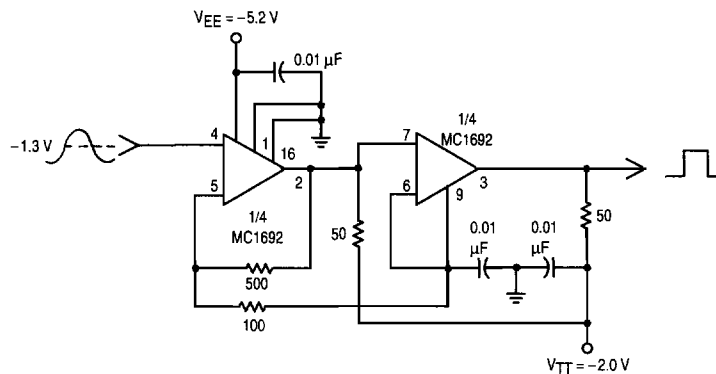

FIGURE 4 — 200 MHz SCHMITT TRIGGER



4