

MGA-43728

2.62–2.69 GHz Linear Power Amplifier Module



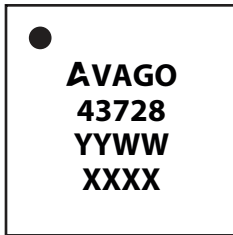
Data Sheet

Description

The Avago MGA-43728 is a fully matched, highly linear power amplifier (PA) designed for use in the 2.62–2.69 GHz band. Based on Avago’s proprietary 0.25um GaAs E-pHEMT technology, the device features high linearity, gain and power-added efficiency (PAE) with integrated power detector and shutdown functions. The MGA-43728 is ideal for use as a final stage PA for Small Cell base transceiver station (BTS) applications.

Component Image

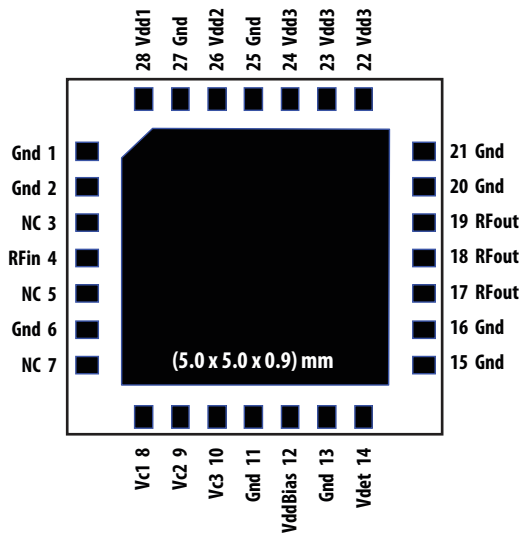
(5.0 × 5.0 × 0.9) mm Package Outline



TOP VIEW

Notes:
 Package marking provides orientation and identification
 "43728" = Device part number
 "YYWW" = Year and work week
 "XXXX" = Assembly lot number

Pin Configuration



Features

- High linearity performance : Typ -50 dBc ACPR1^[1] at 27.0 dBm linear output power (biased with 5.0V supply)
- High Gain : 38.8 dB
- Good efficiency
- Fully matched
- Built-in detector
- GaAs E-pHEMT Technology ^[2]
- Low cost small package size: (5.0 × 5.0 × 0.9) mm

Specifications

2.65 GHz; 5.0 V, Idqtotal = 350 mA (typ), LTE 10 MHz 50 RB

- PAE : 13.4%
- 27.0 dBm linear P_{out} @ ACPR1 = -50 dBc^[1]
- 38.3 dB Gain
- Detector range : 20 dB

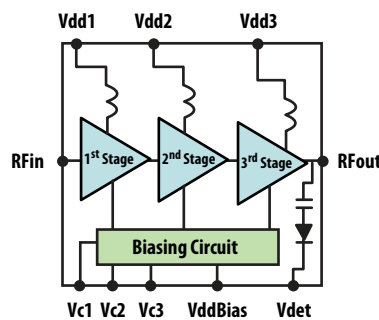
Applications

- Final stage high linearity amplifier for Picocell and Enterprise Femtocell PA targeted for small cell BTS downlink applications.

Note:

1. LTE 10MHz 50 RB Test Mode 1.1 downlink signal.
2. Enhancement mode technology employs positive V_{GS}, thereby eliminating the need of negative gate voltage associated with conventional depletion mode devices.

Functional Block Diagram



Absolute Maximum Rating^[1] $T_A=25^{\circ}\text{C}$

Symbol	Parameter	Units	Absolute Max.
Vdd, VddBias	Supply voltages, bias supply voltage	V	6.0
Vc	Control Voltage	V	(Vdd)
P _{in,max}	CW RF Input Power	dBm	20
P _{diss}	Total Power Dissipation ^[3]	W	7.2
T _j	Junction Temperature	°C	150
T _{STG}	Storage Temperature	°C	-65 to 150

Thermal Resistance^[2,3]

$\theta_{jc} = 14^{\circ}\text{C/W}$

Notes:

1. Operation of this device in excess of any of these limits may cause permanent damage.
2. Thermal resistance measured using Infra-Red Measurement Technique at Vdd=5.5V operating voltage.
3. Board temperature (T_B) is 25 °C, for T_B > 49.2 °C derate the device power at 71.4 mW per °C rise in Board (package belly) temperature.

Electrical Specifications

$T_A = 25^{\circ}\text{C}$, Vdd1,2,3 = VddBias=5.0V, Idqtotal = 350mA, RF performance at 2.65 GHz, LTE 10MHz 50RB Test model 1.1 downlink signal operation unless otherwise stated.

Symbol	Parameter and Test Condition	Units	Min.	Typ.	Max.
Vdd	Supply Voltage	V		5.0	
Idqtotal	Quiescent Supply Current	mA		350	600
Gain	Gain	dB	35	38.3	
OP1dB	Output Power at 1dB Gain Compression	dBm		36	
ACPR1 @ P _{out} =27.0 dBm	LTE 10MHz 50RB Test Mode 1.1 downlink signal	dBc		-50	
PAE	Power Added Efficiency	%	12	13.4	
S11	Input Return Loss, 50Ω source	dB		22	
DetR	Detector RF dynamic range	dB		20	
2fo	2fo Harmonics (LTE 10MHz 50RB Test Mode 1.1 downlink signal)	dBc		-34	

Product Consistency Distribution Charts [1]

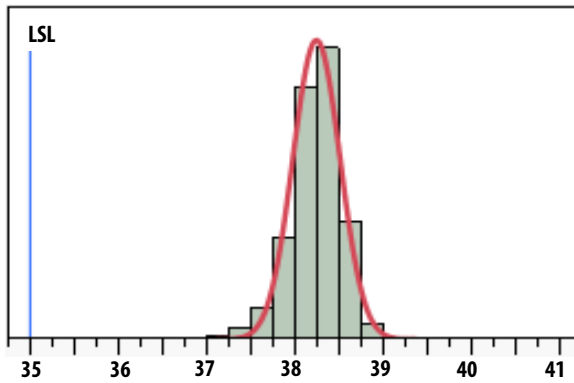


Figure 1. Gain at $P_{out}=27.0$ dBm; LSL=35.0 dB, Nominal = 38.3dB

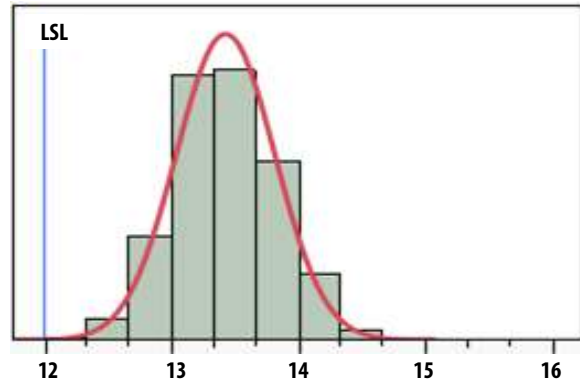


Figure 2. PAE at $P_{out}=27.0$ dBm; LSL=12.0% Nominal = 13.4%

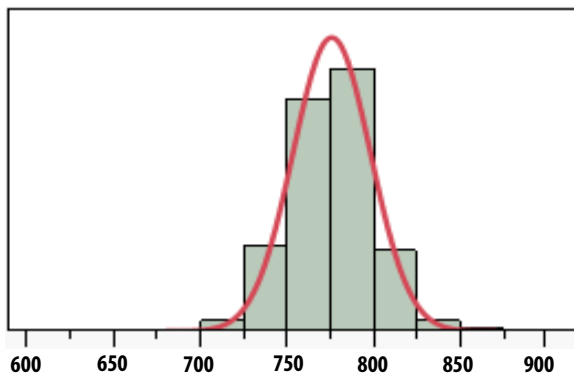


Figure 3. I_{dd_Total} at $P_{out}=27.0$ dBm, Nominal = 776 mA

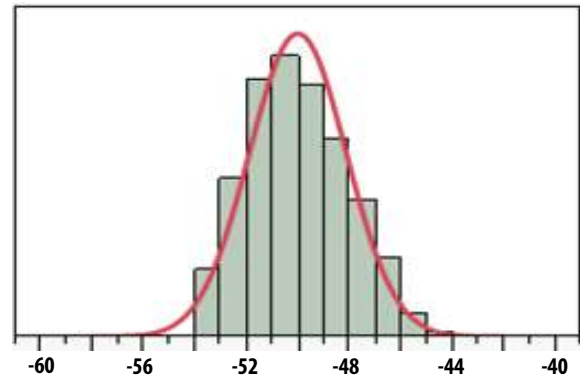


Figure 4. ACLR1 at $P_{out}=27.0$ dBm, Nominal = -50.0 dBc

Note:

1. Distribution data sample size is 1700 samples taken from 3 different wafer lots. $T_A = 25^\circ\text{C}$, $V_{dd}=V_{ddBias} = 5.0\text{V}$, $V_{c1}=2.2\text{V}$, $V_{c2}=2.0\text{V}$, $V_{c3}=2.2\text{V}$, RF performance at 2.65 GHz, unless otherwise stated. Future wafers allocated to this product may have nominal values anywhere between the upper and lower limits.

MGA-43728 typical over-temperature performance at $V_{c1}=2.2V$, $V_{c2}=2.0V$, $V_{c3}=2.2V$ as shown in Figure 27, unless otherwise stated

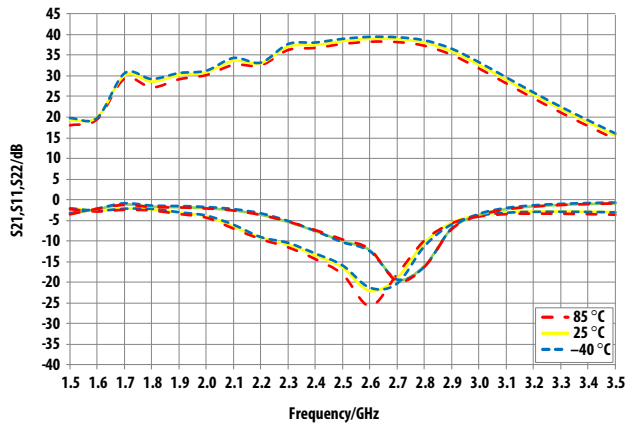


Figure 5. Small-signal performance Over-temperature $V_{dd}=V_{ddBias}=5.0V$ operating voltage

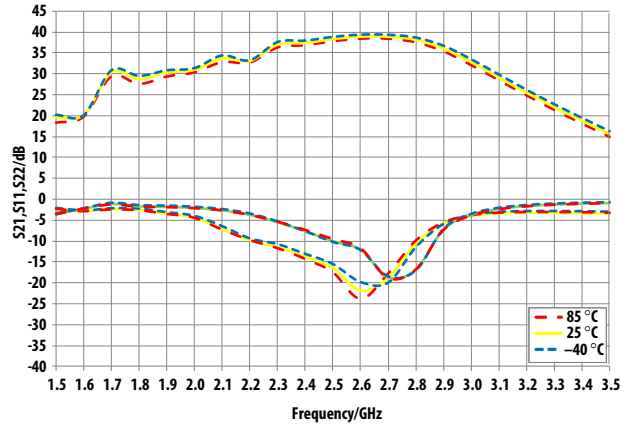


Figure 6. Small-signal performance Over-temperature $V_{dd}=V_{ddBias}=5.5V$ operating voltage

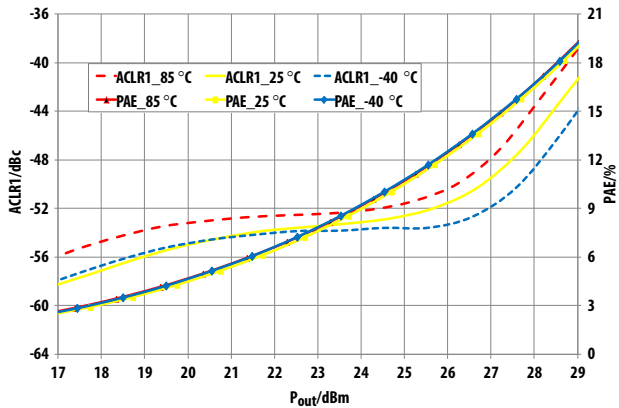


Figure 7. Over-temperature ACLR1, PAE vs P_{out} @ 2.62 GHz $V_{dd}=V_{ddBias}=5.0V$ operating voltage

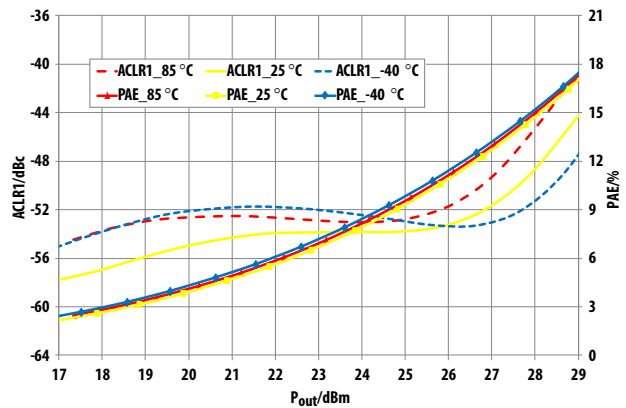


Figure 8. Over-temperature ACLR1, PAE vs P_{out} @ 2.62 GHz $V_{dd}=V_{ddBias}=5.5V$ operating voltage

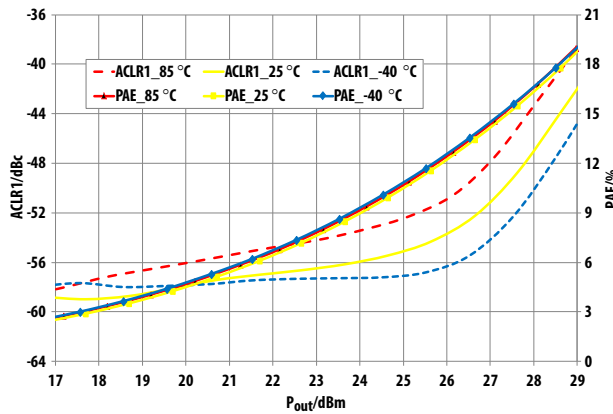


Figure 9. Over-temperature ACLR1, PAE vs P_{out} @ 2.65 GHz $V_{dd}=V_{ddBias}=5.0V$ operating voltage

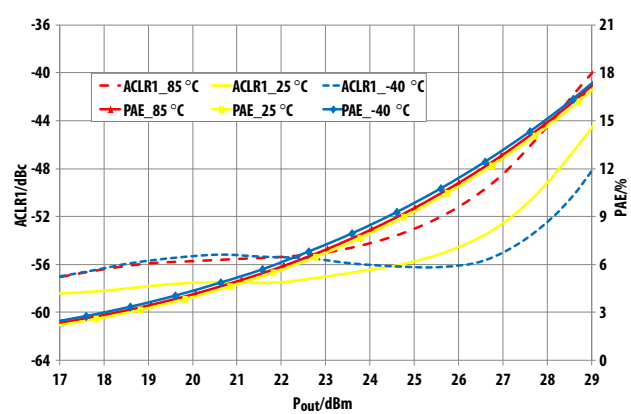
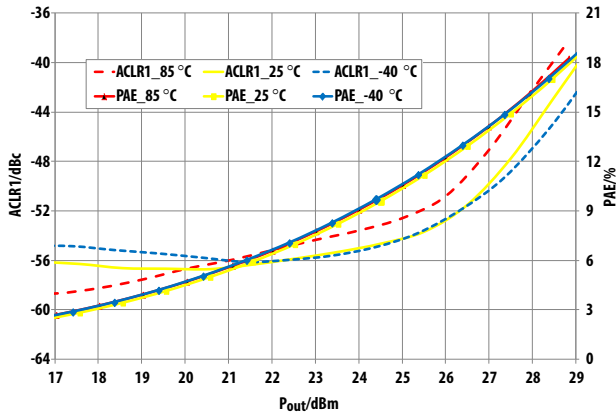
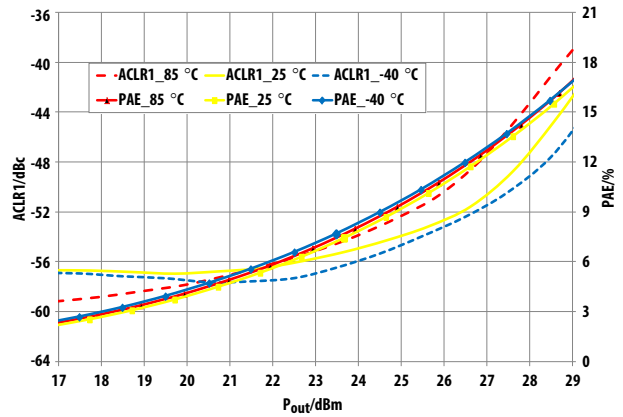


Figure 10. Over-temperature ACLR1, PAE vs P_{out} @ 2.65 GHz $V_{dd}=V_{ddBias}=5.5V$ operating voltage

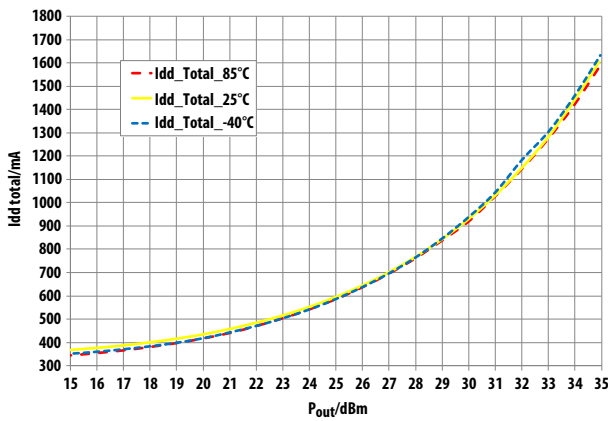
MGA-43728 typical over-temperature performance at Vc1=2.2V, Vc2=2.0V, Vc3=2.2V, unless otherwise stated



**Figure 11. Over-temperature ACLR1, PAE vs P_{out} @ 2.69 GHz
V_{dd}=V_{ddBias}=5.0V operating voltage**

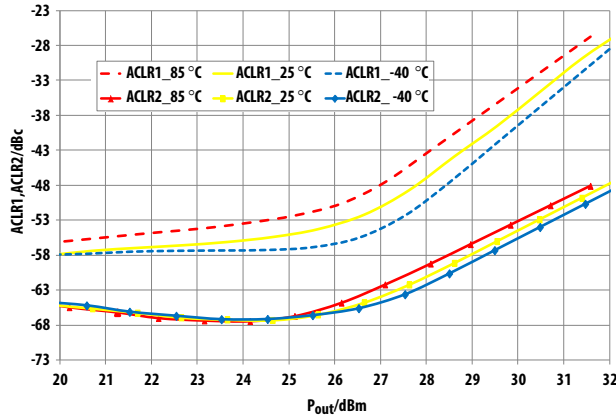


**Figure 12. Over-temperature ACLR1, PAE vs P_{out} @ 2.69 GHz
V_{dd}=V_{ddBias}=5.5V operating voltage**

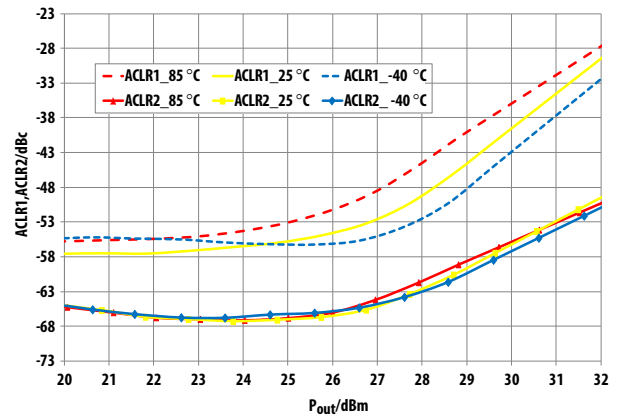


**Figure 13. Over-temperature I_{dd_total} vs P_{out} @ 2.65 GHz
V_{dd}=V_{ddBias}=5.0V operating voltage**

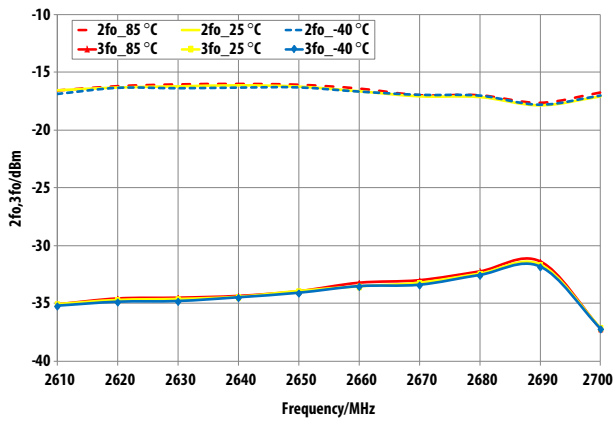
MGA-43728 typical over-temperature performance at Vc1=2.2V, Vc2=2.0V, Vc3=2.2V, unless otherwise stated



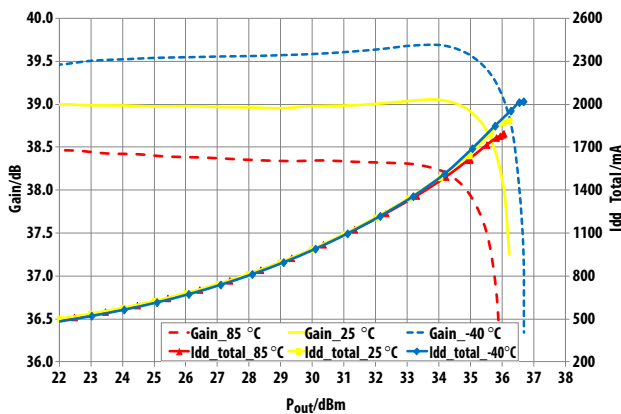
**Figure 14. Over-temperature ACLR1, ACLR2 vs. P_{out} @ 2.65 GHz
V_{dd}=V_{ddBias}=5.0V operating voltage**



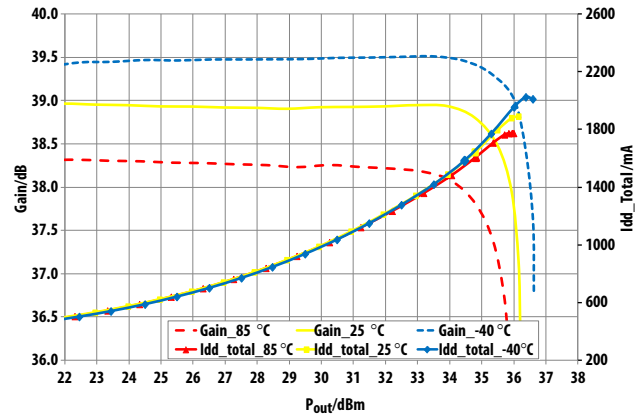
**Figure 15. Over-temperature ACLR1, ACLR2 vs. P_{out} @ 2.65 GHz
V_{dd}=V_{ddBias}=5.5V operating voltage**



**Figure 16. Over-temperature 2nd, 3rd Harmonics vs. Freq at P_{out}=27.0 dBm,
V_{dd}=V_{ddBias}=5.0V operating voltage**

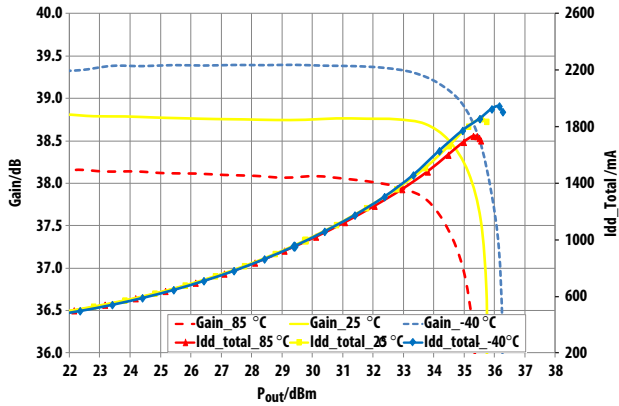


**Figure 17. Over-temperature Gain, I_{dd_total} vs. P_{out} @ 2.62 GHz
V_{dd}=V_{ddBias}=5.0V operating voltage**

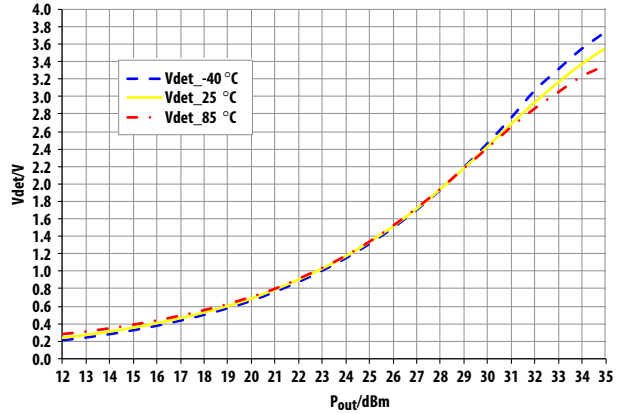


**Figure 18. Over-temperature Gain, I_{dd_total} vs. P_{out} @ 2.65 GHz
V_{dd}=V_{ddBias}=5.0V operating voltage**

MGA-43728 typical over-temperature performance at Vc1=2.2V, Vc2=2.0V, Vc3=2.2V, unless otherwise stated



**Figure 19. Over-temperature Gain, Idd_total vs. P_{out} @ 2.69 GHz
V_{dd}=V_{ddBias}=5.0V operating voltage**



**Figure 20. Over-temperature Vdet vs. P_{out} @ 2.69 GHz,
V_{dd}=V_{ddBias}=5.0V operating voltage**

MGA-43728 typical LTE 10MHz 50RB Test model 1.1 downlink signal Spectrum Emission Mask (3GPP TS 36.141v8.2.0 [2009-03] standard) performance at V_{dd}=V_{ddBias}=5.0V, Vc1=2.2V, Vc2=2.0V, Vc3=2.2V, unless otherwise stated

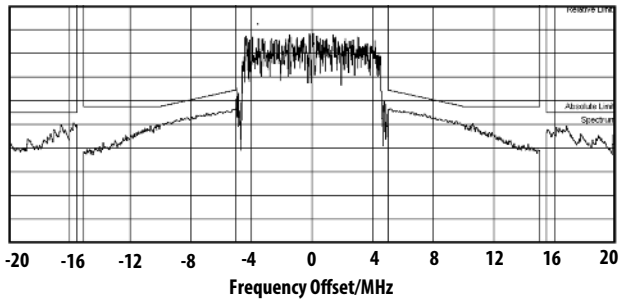


Figure 21. SEM at P_{out}=31 dBm @ 2.62 GHz

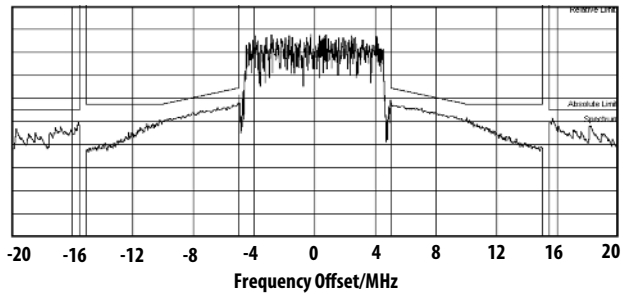


Figure 22. SEM at P_{out}=31 dBm @ 2.65 GHz

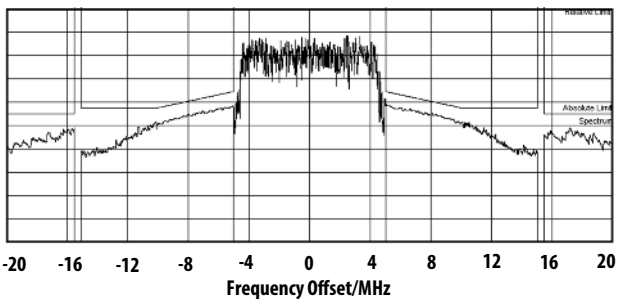


Figure 23. SEM at P_{out}=31 dBm @ 2.69 GHz

MGA-43728 typical LTE 20MHz 100RB performance at Vdd=VddBias=5.0V, Vc1=2.4V, Vc2=2.3V, Vc3=2.3V, unless otherwise stated

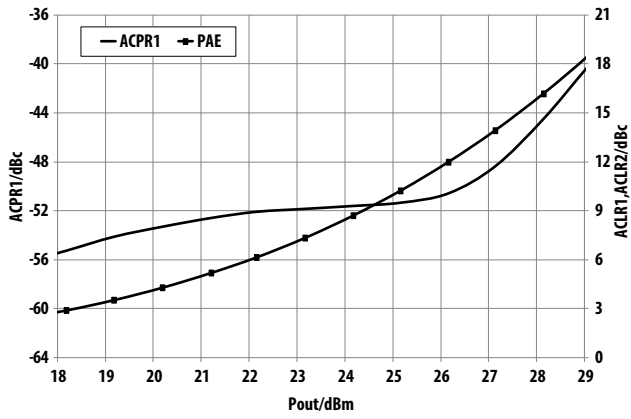


Figure 24. ACPR1, PAE vs Pout @ 2.63GHz

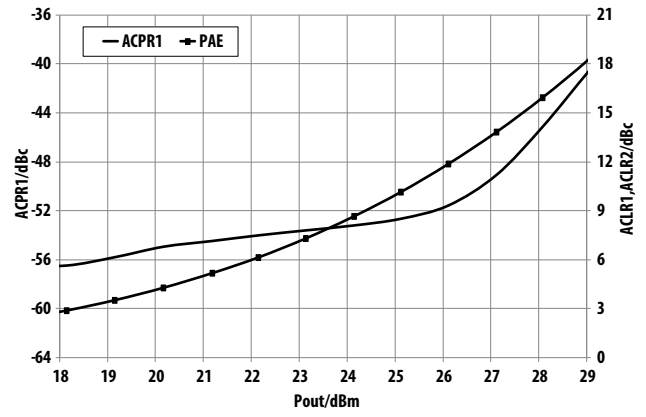


Figure 25. ACPR1, PAE vs Pout @ 2.65GHz

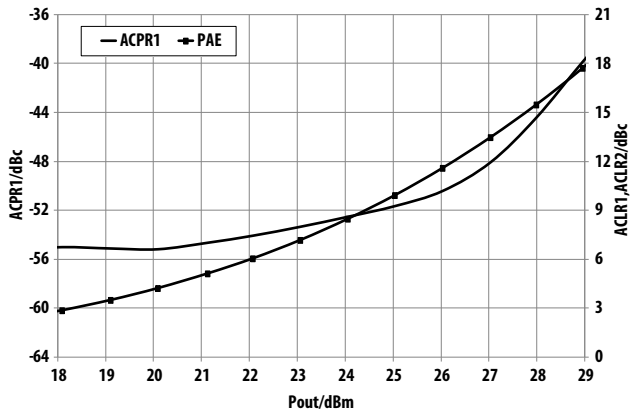


Figure 26. ACPR1, PAE vs Pout @ 2.68GHz

S-Parameter^[1] (Vdd=VddBias=5.0V, Vc1=2.2V, Vc2=2.0V, Vc3=2.2V), T=25 °C, 50 Ω matched)

Freq (GHz)	S11 (dB)	S11 (ang)	S21 (dB)	S21 (ang)	S12 (dB)	S12 (ang)	S22 (dB)	S22 (ang)
0.1	-0.02	-34.40	-60.68	59.73	-60.23	128.69	-0.36	166.30
0.2	-0.04	-67.37	-63.52	14.97	-59.18	5.31	-0.67	155.18
0.3	-0.10	-97.79	-67.50	-67.21	-66.31	57.08	-0.90	145.01
0.4	-0.20	-125.48	-53.74	-47.51	-64.36	-46.51	-1.00	134.75
0.5	-0.28	-150.38	-41.70	-49.55	-66.10	79.33	-1.11	124.39
0.6	-0.32	-173.17	-28.45	-72.49	-68.49	149.55	-1.20	114.04
0.7	-0.33	165.59	-16.16	-103.41	-65.82	63.98	-1.27	103.65
0.8	-0.34	144.26	-3.64	-146.70	-65.91	71.56	-1.36	93.26
0.9	-1.17	122.06	7.99	132.57	-67.60	30.82	-1.45	82.80
1.0	-1.62	111.26	10.15	48.80	-66.49	20.24	-1.57	72.58
1.1	-1.33	95.87	11.42	-1.57	-63.37	17.31	-1.66	62.78
1.2	-1.22	79.18	13.36	-47.43	-60.74	-8.20	-1.63	53.67
1.3	-1.36	62.53	9.27	-84.49	-66.62	-2.40	-1.03	42.09
1.4	-1.21	46.64	18.82	-82.29	-61.09	-11.27	-1.79	26.55
1.5	-1.56	26.94	22.45	-147.92	-58.43	-46.14	-2.44	21.19
1.6	-2.30	15.25	20.18	-161.36	-57.84	-74.21	-1.65	14.71
1.7	-2.09	1.53	28.83	159.04	-59.90	-94.94	-0.72	0.86
1.8	-1.91	-17.74	27.06	69.42	-60.70	-105.36	-1.33	-16.62
1.9	-2.43	-36.36	22.73	83.08	-60.48	-86.10	-1.42	-28.21
2.0	-3.15	-57.05	29.27	63.59	-63.62	-97.01	-1.57	-41.94
2.1	-4.84	-82.36	33.36	20.37	-59.22	-86.18	-1.94	-57.45
2.2	-10.50	-89.78	33.75	-36.40	-56.17	-106.46	-2.85	-72.30
2.3	-10.37	-87.69	35.13	-54.12	-55.02	-119.03	-4.01	-86.89
2.4	-13.05	-85.24	37.62	-105.77	-52.71	-127.09	-5.62	-96.96
2.5	-13.52	-72.73	38.48	-151.40	-51.31	-155.90	-6.71	-105.13
2.6	-12.66	-70.09	38.67	161.17	-49.40	-3.01	-7.93	-121.64
2.7	-11.89	-59.83	38.44	114.17	-48.38	152.67	-12.65	-147.56
2.8	-8.09	-57.36	37.57	65.03	-48.18	120.20	-20.22	73.21
2.9	-4.83	-74.50	35.49	16.46	-49.60	89.32	-9.01	-23.72
3.0	-3.33	-96.30	32.40	-26.10	-51.59	61.67	-4.45	-55.63
3.1	-2.80	-116.04	29.01	-61.72	-53.83	47.39	-2.64	-80.03
3.2	-2.69	-133.35	25.69	-92.18	-57.05	28.60	-1.80	-99.60
3.3	-2.76	-148.65	22.53	-119.03	-60.51	20.35	-1.36	-116.31
3.4	-2.86	-162.71	19.55	-143.46	-61.36	-6.36	-1.11	-131.21
3.5	-3.01	-176.10	16.71	-166.19	-63.62	-13.29	-0.95	-144.98
3.6	-3.22	171.31	13.99	172.45	-66.28	-16.78	-0.86	-157.98
3.7	-3.40	159.49	11.36	152.16	-68.28	17.49	-0.79	-170.33
3.8	-3.53	148.11	8.76	132.58	-69.69	-5.35	-0.77	177.66
3.9	-3.62	136.71	6.14	113.60	-70.85	5.60	-0.75	165.99
4.0	-3.72	125.31	3.39	95.28	-61.47	22.84	-0.74	154.50
4.1	-3.80	113.97	0.46	77.64	-65.27	19.13	-0.75	143.20
4.2	-3.88	102.65	-2.87	61.13	-63.90	26.35	-0.76	132.01
4.3	-3.97	91.43	-6.96	46.92	-63.28	-8.95	-0.77	120.85
4.4	-4.03	80.26	-12.73	41.80	-61.88	9.38	-0.80	109.87
4.5	-4.08	69.11	-17.06	74.23	-62.47	-0.60	-0.81	98.84
4.6	-4.15	57.93	-17.02	104.76	-60.38	-25.12	-0.85	87.77
4.7	-4.19	46.87	-11.81	118.08	-60.46	-10.13	-0.89	76.81
4.8	-4.23	35.90	-8.10	105.69	-59.79	-23.10	-0.93	65.77
4.9	-4.26	25.12	-5.56	87.65	-58.18	-49.38	-0.99	54.67

5.0	-4.26	14.39	-3.60	66.28	-57.03	-54.35	-1.07	43.55
5.1	-4.22	3.93	-2.09	41.50	-55.73	-64.12	-1.20	32.48
5.2	-4.13	-6.41	-1.23	12.10	-55.04	-79.97	-1.38	21.57
5.3	-3.99	-16.65	-2.02	-20.94	-54.33	-105.82	-1.60	11.53
5.4	-3.70	-26.46	-5.72	-34.73	-54.39	-126.07	-1.69	2.54
5.5	-3.06	-37.88	-2.62	-26.71	-55.93	-134.66	-1.57	-6.98
5.6	-2.68	-53.09	0.43	-65.71	-56.43	-153.44	-1.42	-17.51
5.7	-2.85	-67.65	-0.16	-105.50	-55.76	-155.99	-1.33	-28.44
5.8	-3.12	-80.15	-1.88	-136.97	-58.46	-174.53	-1.27	-39.44
5.9	-3.35	-91.32	-3.82	-162.74	-59.03	174.87	-1.23	-50.47
6.0	-3.52	-102.07	-5.70	174.80	-58.37	163.85	-1.20	-61.45
7.0	-3.94	156.18	-21.58	-16.68	-58.83	77.65	-1.06	-168.16
8.0	-3.91	50.31	-23.18	-5.77	-57.82	-30.72	-1.05	89.43
9.0	-4.08	-54.33	-29.29	-83.88	-55.40	-129.15	-0.91	-9.39
10.0	-4.27	-159.19	-30.01	133.70	-53.13	124.23	-1.29	-118.90
11.0	-4.55	92.04	-31.20	-5.77	-54.30	-5.06	-1.83	125.37
12.0	-3.70	-21.80	-33.32	-145.93	-52.58	-114.41	-1.85	8.38
13.0	-2.76	-123.32	-36.65	75.45	-53.24	142.18	-1.62	-104.69
14.0	-2.51	141.66	-41.40	-71.66	-57.91	22.50	-1.53	151.99
15.0	-3.30	34.24	-48.00	-3.21	-53.75	-58.83	-1.84	44.89
16.0	-4.41	-95.00	-41.00	-156.42	-46.24	-128.35	-3.35	-97.02
17.0	-4.41	145.78	-41.81	46.49	-48.30	67.23	-4.00	131.04
18.0	-2.46	49.63	-42.63	-74.92	-47.45	-39.31	-2.25	38.64
19.0	-1.76	-49.30	-42.04	171.81	-47.18	-145.00	-1.79	-52.13
20.0	-2.43	-169.80	-38.88	44.24	-41.59	88.78	-2.61	-161.34

S-Parameter^[1] (Vdd=VddBias=5.5V, Vc1=2.2V, Vc2=2.0V, Vc3=2.0V), T=25 °C, 50 Ω matched)

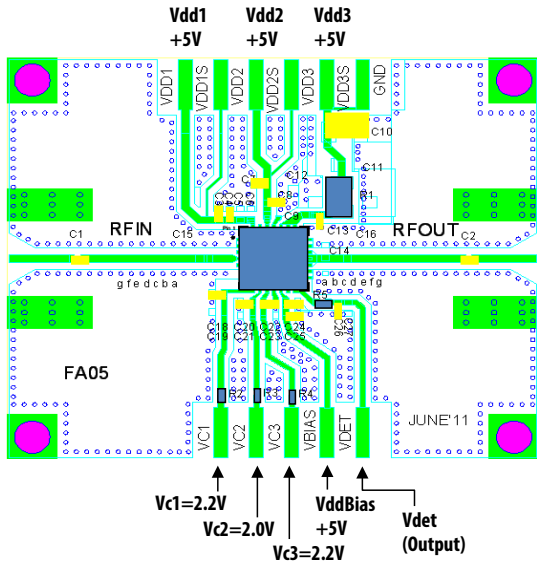
Freq (GHz)	S11 (dB)	S11 (ang)	S21 (dB)	S21 (ang)	S12 (dB)	S12 (ang)	S22 (dB)	S22 (ang)
0.1	-0.01	-34.34	-65.80	-44.41	-54.51	-24.21	-0.38	166.10
0.2	-0.03	-67.31	-66.10	64.27	-62.58	-52.03	-0.68	155.03
0.3	-0.10	-97.81	-61.97	-36.43	-65.44	-80.31	-0.91	144.88
0.4	-0.20	-125.47	-56.52	-41.90	-73.50	-40.66	-1.02	134.68
0.5	-0.28	-150.36	-41.04	-48.57	-64.63	97.94	-1.13	124.32
0.6	-0.32	-173.14	-28.13	-73.41	-68.11	74.78	-1.22	114.01
0.7	-0.32	165.58	-15.86	-104.01	-72.33	-12.21	-1.30	103.62
0.8	-0.33	144.22	-3.36	-147.24	-64.01	74.39	-1.39	93.24
0.9	-1.18	121.97	8.25	132.18	-68.30	10.47	-1.48	82.84
1.0	-1.64	111.29	10.45	48.51	-64.96	25.14	-1.60	72.64
1.1	-1.34	95.92	11.74	-1.99	-61.65	6.42	-1.69	62.91
1.2	-1.23	79.18	13.69	-47.99	-61.96	-1.00	-1.65	53.85
1.3	-1.37	62.49	9.51	-84.48	-65.72	-26.62	-1.03	42.10
1.4	-1.22	46.58	19.30	-82.39	-60.25	-9.53	-1.82	26.45
1.5	-1.60	26.66	22.96	-149.62	-58.15	-41.97	-2.50	21.46
1.6	-2.36	15.36	20.49	-163.39	-59.29	-68.59	-1.66	15.03
1.7	-2.12	1.67	29.11	157.25	-58.46	-83.28	-0.70	1.06
1.8	-1.96	-17.82	27.26	67.51	-61.91	-94.43	-1.35	-16.52
1.9	-2.52	-36.42	22.96	81.80	-63.80	-95.81	-1.42	-28.12
2.0	-3.30	-57.10	29.48	61.74	-62.99	-88.62	-1.58	-41.90
2.1	-5.12	-82.06	33.53	18.39	-59.50	-94.92	-1.98	-57.38
2.2	-10.83	-86.19	33.82	-38.01	-56.48	-93.20	-2.90	-71.91
2.3	-10.38	-83.74	35.15	-55.95	-55.31	-116.44	-4.07	-86.16

2.4	-12.54	-81.61	37.59	-106.76	-52.71	-131.85	-5.57	-95.84
2.5	-12.84	-72.89	38.46	-151.78	-51.26	-157.55	-6.59	-104.08
2.6	-12.30	-71.96	38.71	161.22	-49.36	-0.86	-7.78	-120.62
2.7	-11.82	-61.63	38.55	114.36	-48.60	152.76	-12.21	-145.87
2.8	-8.10	-58.00	37.74	65.13	-48.78	120.36	-20.39	74.86
2.9	-4.78	-74.82	35.70	16.30	-49.60	88.60	-9.18	-23.66
3.0	-3.27	-96.61	32.62	-26.51	-52.02	65.61	-4.49	-55.59
3.1	-2.74	-116.44	29.23	-62.29	-54.50	42.81	-2.67	-80.08
3.2	-2.64	-133.75	25.90	-92.83	-57.19	19.43	-1.82	-99.67
3.3	-2.71	-149.05	22.73	-119.74	-57.47	12.53	-1.36	-116.36
3.4	-2.83	-163.12	19.74	-144.21	-60.96	12.00	-1.11	-131.24
3.5	-3.00	-176.48	16.90	-166.94	-63.05	17.86	-0.95	-144.98
3.6	-3.21	171.04	14.18	171.69	-66.43	2.22	-0.86	-157.99
3.7	-3.39	159.32	11.55	151.35	-65.99	34.17	-0.80	-170.34
3.8	-3.51	147.93	8.95	131.74	-70.78	107.07	-0.78	177.67
3.9	-3.60	136.53	6.32	112.71	-65.11	35.74	-0.75	165.99
4.0	-3.70	125.16	3.57	94.36	-66.32	11.79	-0.74	154.51
4.1	-3.78	113.82	0.63	76.71	-66.00	45.82	-0.75	143.23
4.2	-3.86	102.52	-2.69	60.19	-65.21	28.66	-0.76	132.03
4.3	-3.94	91.31	-6.79	45.94	-65.35	5.62	-0.78	120.85
4.4	-4.01	80.13	-12.57	40.90	-61.66	-7.85	-0.80	109.88
4.5	-4.06	68.98	-16.88	73.17	-61.20	-1.80	-0.82	98.84
4.6	-4.12	57.82	-16.85	103.65	-60.49	-3.68	-0.85	87.73
4.7	-4.17	46.74	-11.65	116.89	-60.80	-13.05	-0.89	76.79
4.8	-4.20	35.76	-7.97	104.45	-58.58	-29.71	-0.94	65.74
4.9	-4.23	24.97	-5.44	86.38	-59.19	-44.50	-1.00	54.65
5.0	-4.23	14.21	-3.50	64.97	-56.49	-59.15	-1.08	43.51
5.1	-4.20	3.72	-2.01	40.25	-56.80	-66.37	-1.20	32.45
5.2	-4.11	-6.62	-1.19	10.99	-55.98	-87.47	-1.38	21.54
5.3	-3.97	-16.91	-2.00	-21.70	-55.31	-99.13	-1.61	11.43
5.4	-3.69	-26.75	-5.66	-35.05	-54.41	-133.79	-1.70	2.35
5.5	-3.07	-38.16	-2.49	-27.35	-57.87	-141.05	-1.58	-7.16
5.6	-2.69	-53.27	0.55	-66.47	-56.52	-149.49	-1.44	-17.67
5.7	-2.86	-67.71	-0.04	-106.23	-56.66	-168.73	-1.35	-28.56
5.8	-3.13	-80.15	-1.76	-137.73	-58.16	0.75	-1.28	-39.58
5.9	-3.35	-91.37	-3.69	-163.58	-58.12	-1.66	-1.25	-50.59
6.0	-3.51	-102.11	-5.58	173.94	-59.00	174.04	-1.22	-61.56
7.0	-3.93	156.02	-21.54	-17.44	-59.00	75.92	-1.07	-168.23
8.0	-3.90	50.10	-23.09	173.38	-58.48	-29.55	-1.06	89.37
9.0	-4.08	-54.56	-29.23	-84.75	-56.21	-132.72	-0.91	-9.52
10.0	-4.29	-159.31	-29.93	132.57	-53.74	123.42	-1.28	-118.91
11.0	-4.61	92.24	-31.28	-7.37	-54.32	3.69	-1.77	125.87
12.0	-3.75	-21.28	-33.22	-147.61	-52.92	-112.01	-1.75	8.22
13.0	-2.75	-123.09	-36.73	74.37	-53.08	141.58	-1.58	-105.16
14.0	-2.53	141.64	-41.16	-73.48	-56.22	36.53	-1.50	151.88
15.0	-3.32	34.10	-48.65	-0.46	-53.44	-61.14	-1.84	44.77
16.0	-4.39	-95.26	-40.70	-154.65	-46.47	-127.22	-3.33	-97.63
17.0	-4.37	145.65	-41.85	44.10	-48.49	66.41	-3.88	129.93
18.0	-2.45	49.58	-42.76	-74.57	-48.06	-36.92	-2.22	38.30
19.0	-1.75	-49.40	-41.72	172.94	-46.61	-144.48	-1.78	-52.35
20.0	-2.43	-169.97	-38.62	43.74	-41.30	88.29	-2.62	-161.56

Note:

1. S-parameter is measured with deembedded reference plane at DUT RFin and RFout pins.

Demonstration Board Top View (Vdd=VddBias=5.0V operating voltage)



Component	Value	Part Number
C1, C2, C18, C20, C22	7.5 pF ± 0.5 pF	GJM1555C1H7R5BB01D
C3, C7, C13, C25	0.1 μF ± 10%	GRM155R71C104KA88D
C4, C8	8.2 pF ± 0.5 pF	GJM1555C1H8R2BB01D
C24	6.0 pF ± 0.5 pF	GJM1555C1H6R0CB01D
C10	2.2 μF ± 10%	GRM21BR71E225KA73L
C26	22 nF ± 10%	CM05X7R223K16AHF
R1	0 Ω	RMC1/10 JPTP
R2, R3, R4, R5	0 Ω	RMC1/16S JPTH

Note:

For performance optimization control voltage for individual stages can be adjusted by varying R2, R3 and R4 resistor value.

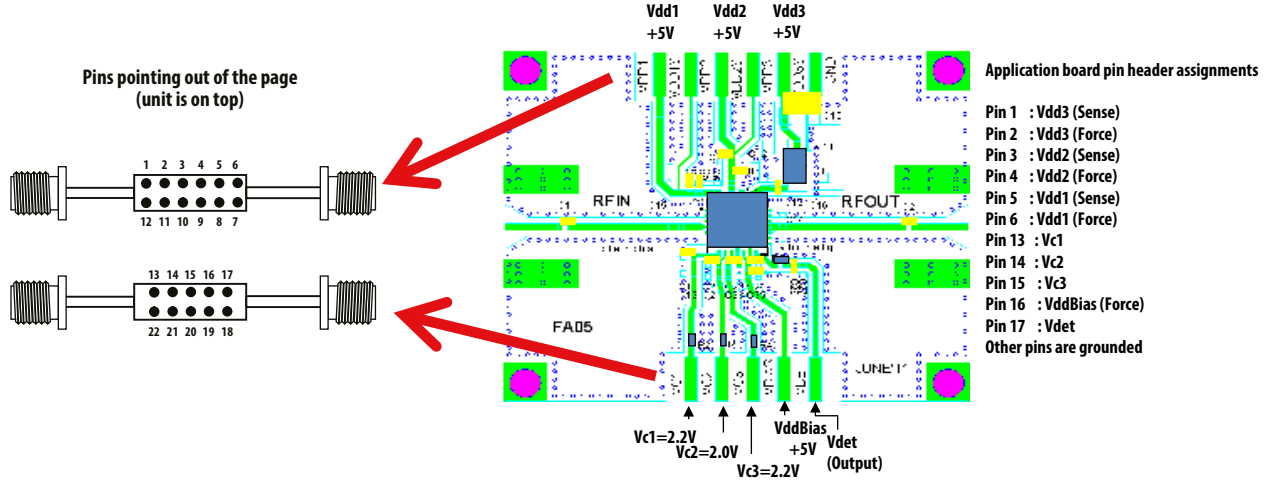


Figure 27. Demonstration board application circuit for MGA-43728 module

Application Schematic

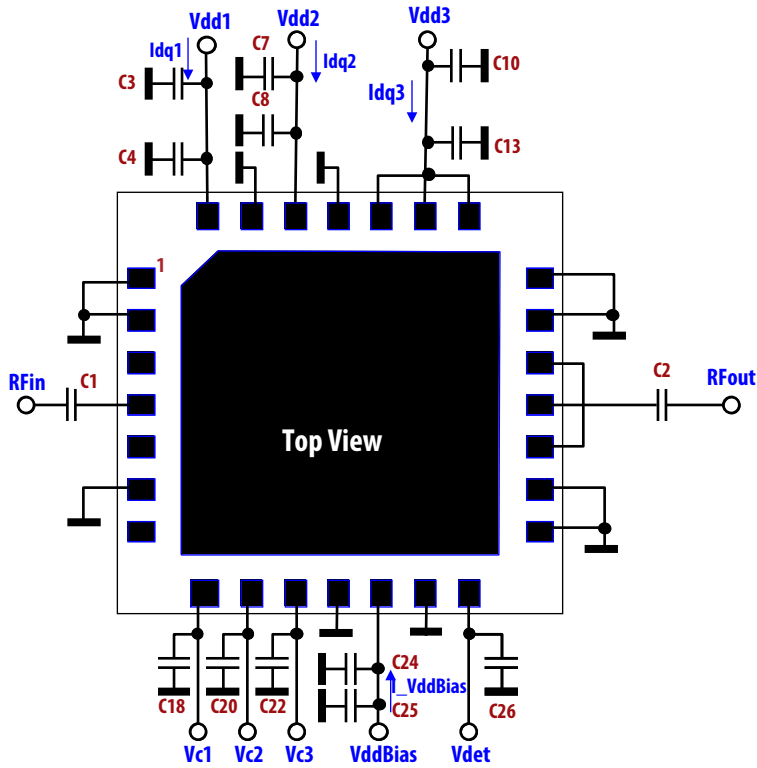


Figure 28. Application schematic in demonstration board

Notes

1. All capacitors on supply lines are bypass capacitors
2. C1 / C2 are RF coupling capacitors.
3. $I_{dq1} = 45.0\text{mA}$, $I_{dq2} = 100.0\text{mA}$, $I_{dq3} = 200.0\text{mA}$, $I_{VddBias} = 14.0\text{mA}$. $I_{dq1/2/3}$ are adjusted by voltages to CMOS-compatible control pins Vc1/2/3 respectively. These typical bias currents were obtained with Vc1/2/3 voltages, as in Figure 28. Adjustment of these currents enable optimum bias conditions to be achieved for best linearity and efficiency for a given modulation type.

MGA-43728 typical I_{c1} , I_{c2} , I_{c3} Vs V_c performance, unless otherwise stated

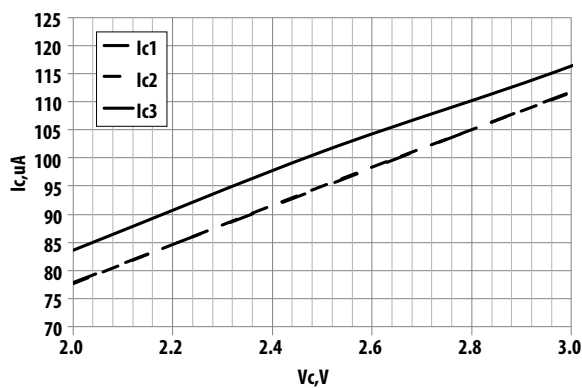


Figure 29. I_c Versus V_c at $V_{dd}=V_{ddBias}=5.0\text{V}$

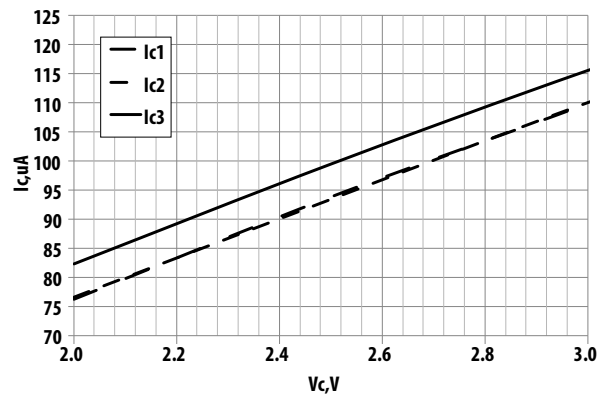
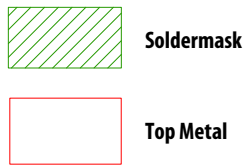
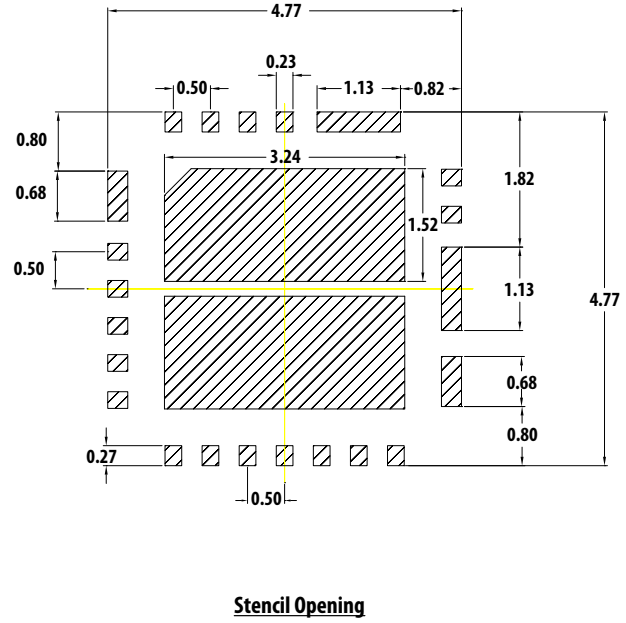
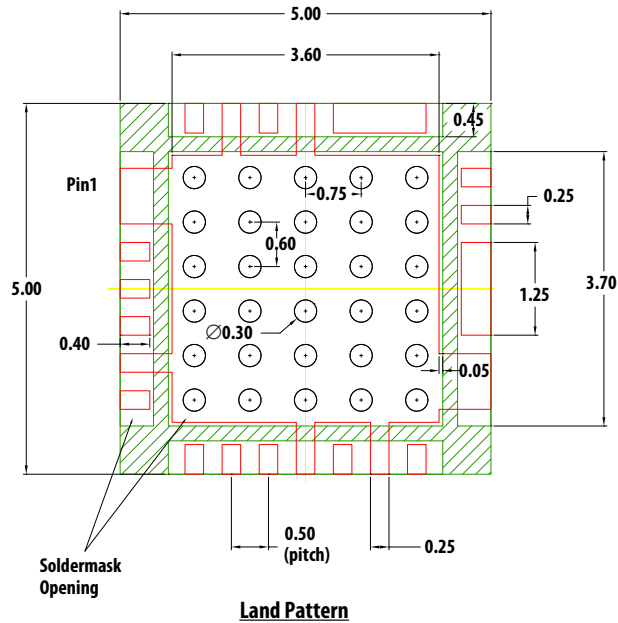
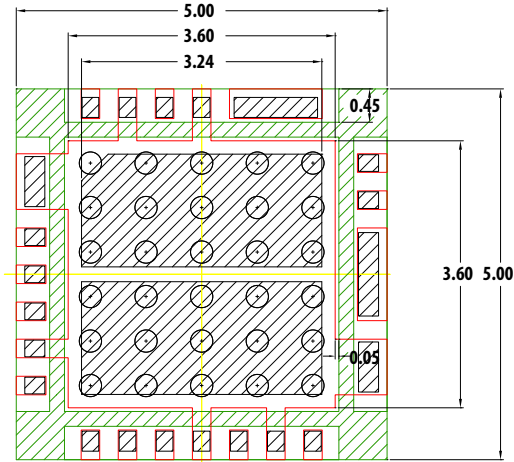


Figure 30. I_c Versus V_c at $V_{dd}=V_{ddBias}=5.5\text{V}$

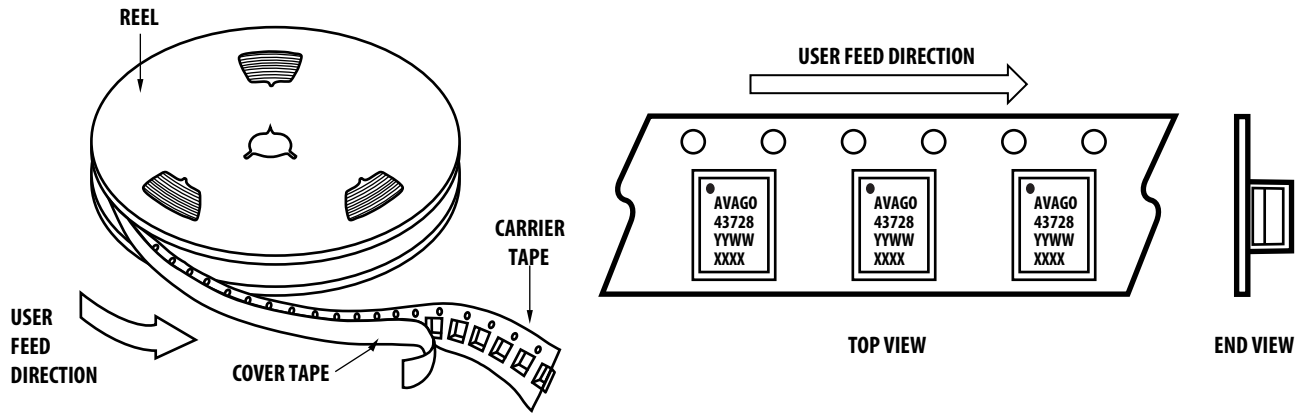
PCB Land Pattern and Stencil Outline



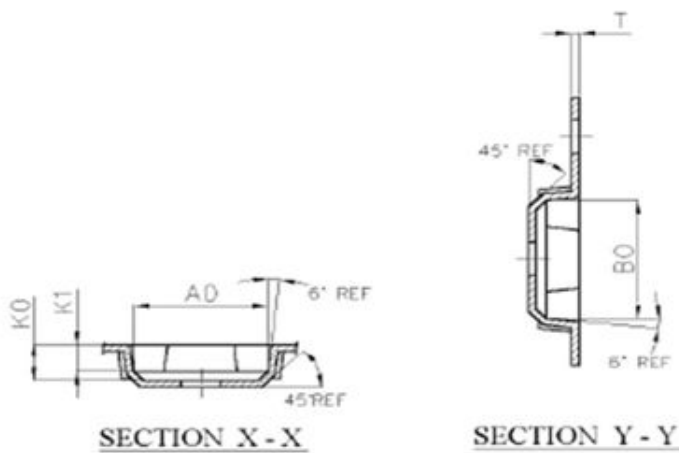
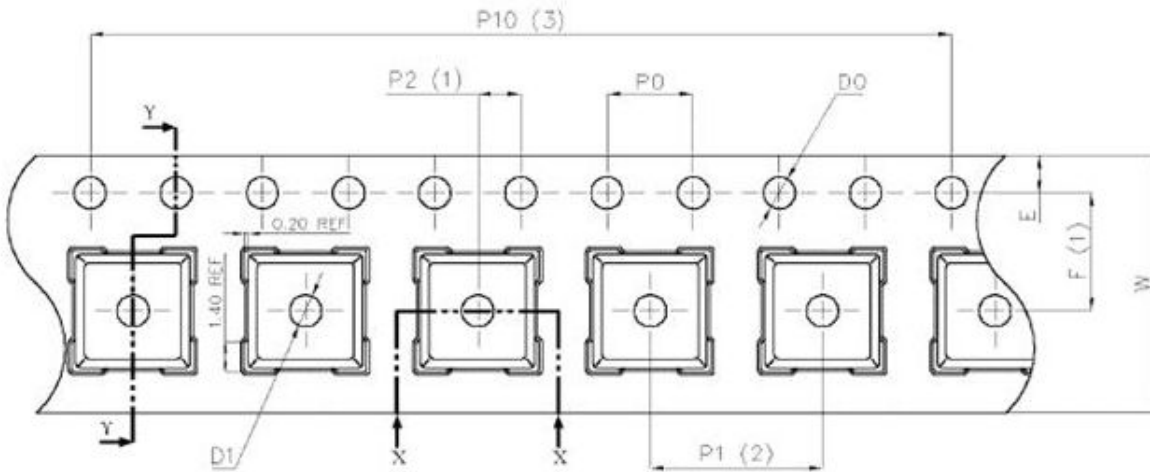
- Note :**
1. Recommended Land Pattern and Stencil.
 2. 4 mils stencil thickness recommended.
 3. All dimensions are in mm



Device Orientation

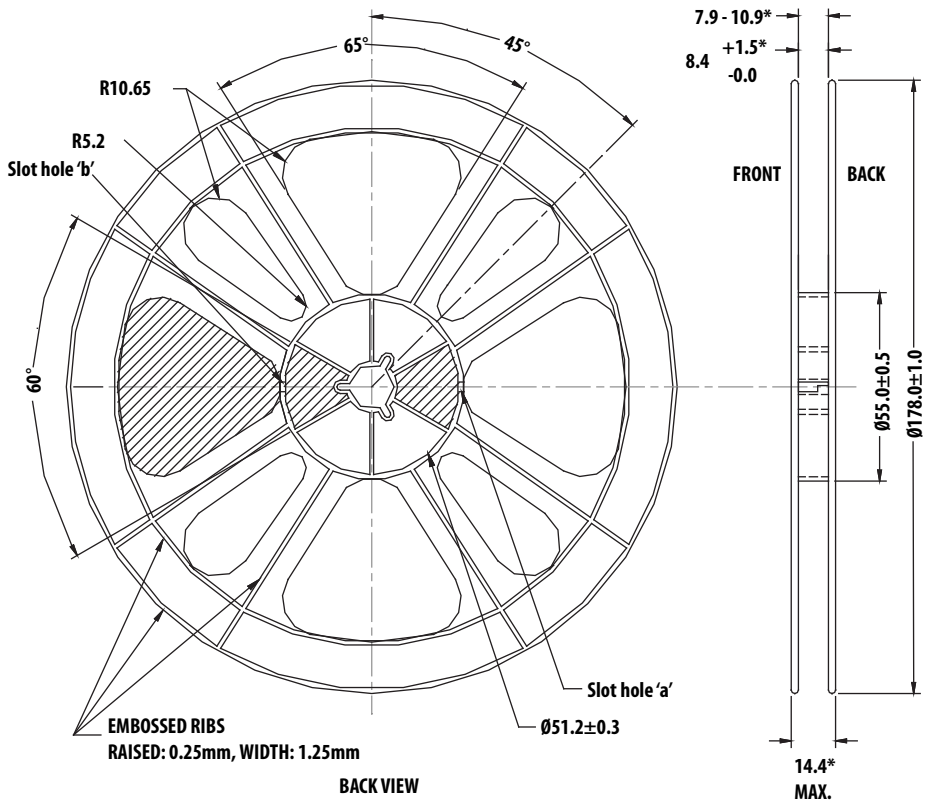
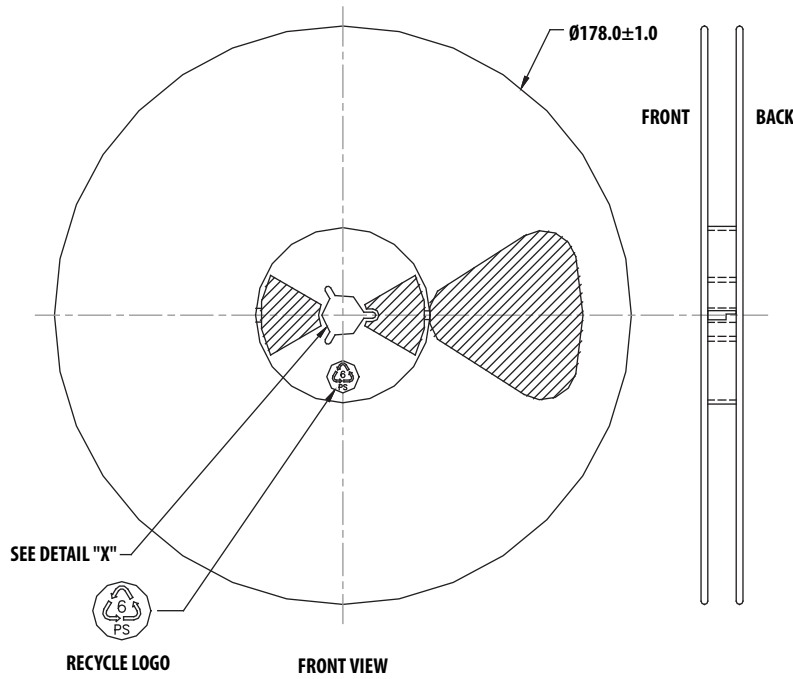


Tape Dimensions



Dimension List			
Annote	Millimeter	Annote	Millimeter
A0	5.40±0.10	P0	4.00±0.10
B0	5.40±0.10	P2	2.00±0.10
D0	1.50 ^{+0.10} ₀	P10	40.00±0.20
D1	1.60±0.10	E	1.75±0.10
K0	1.90±0.10	F	5.50±0.10
K1	1.50±0.10	T	0.30±0.03
P1	8.00±0.10	W	12.00±0.30

Reel Dimensions (7" reel)



For product information and a complete list of distributors, please go to our web site: www.avagotech.com

Avago Technologies, and the A logo are trademarks of Avago Technologies in the United States and other countries.
Data subject to change. Copyright © 2005-2015 Avago Technologies. All rights reserved.
AV02-4221EN - November 5, 2015

