

| REVISIONS |     |                           |           |            |
|-----------|-----|---------------------------|-----------|------------|
| P         | LTN | DESCRIPTION               | DATE      | APVD       |
| A         |     | REVISED PER ECN-21-111555 | 02AUG2021 | W. H. D. Z |
| A1        |     | REVISED PER ECR-22-136618 | 22APR2022 | WH LC      |
|           |     |                           |           |            |

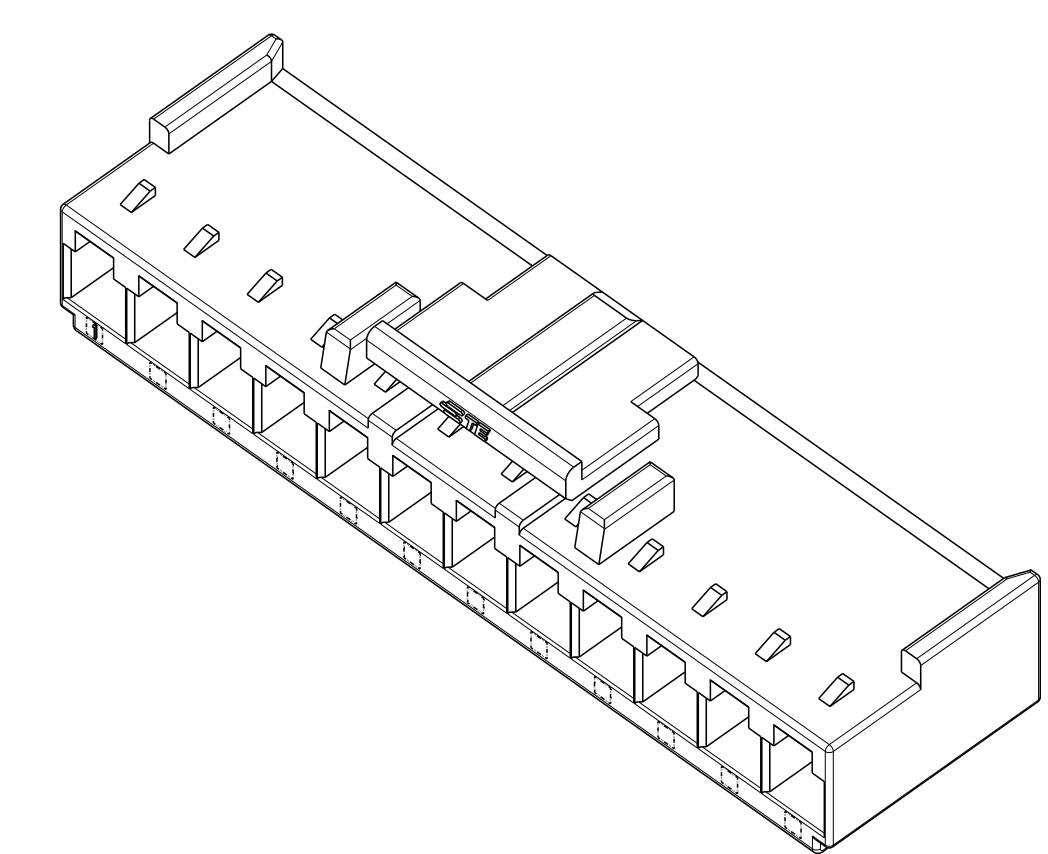

- △ MATERIAL: NYLON,UL94 V-0, COLOR: NATURAL
- DIMENSIONS SHOWN REPRESENT PRODUCT IN DRY, AS MOLDED, CONDITION. ADDITIONAL 2% GROWTH DUE TO SUBSEQUENT MOISTURE ABSORPTION MAY OCCUR AND SHOULD BE ACCOUNTED FOR.
  - THE HOUSING ACCEPTS TERMINALS: 2377991-1 OR 2377997-1
  - RECOMMENDED MATING PARTS: [ ]-2375239-[ ] OR [ ]-2384269-[ ]
  - ACCEPT OPTIONAL TPA: 1-2132782-2 OR [ ]-1744544-[ ]
  - PER IEC 60335-1 SECT. 30, GWEPT 750C, NO FLAME OR Te-Ti≤2S
  - PACKAGING: LOOSE PIECE.

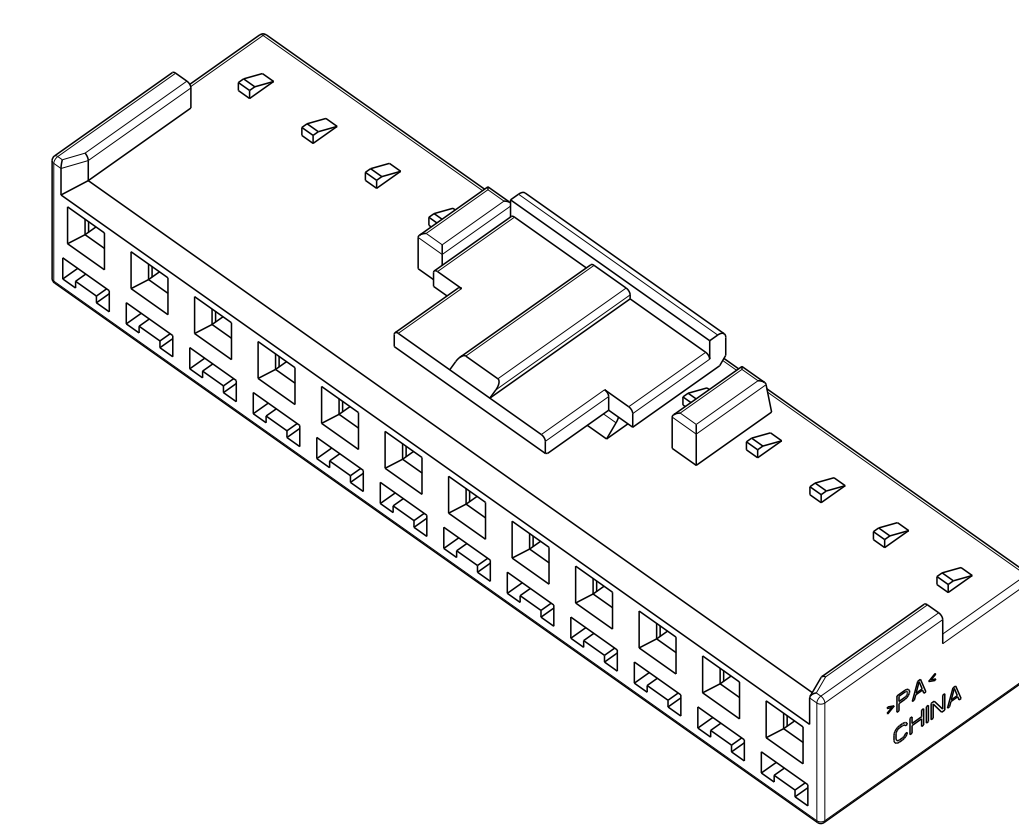
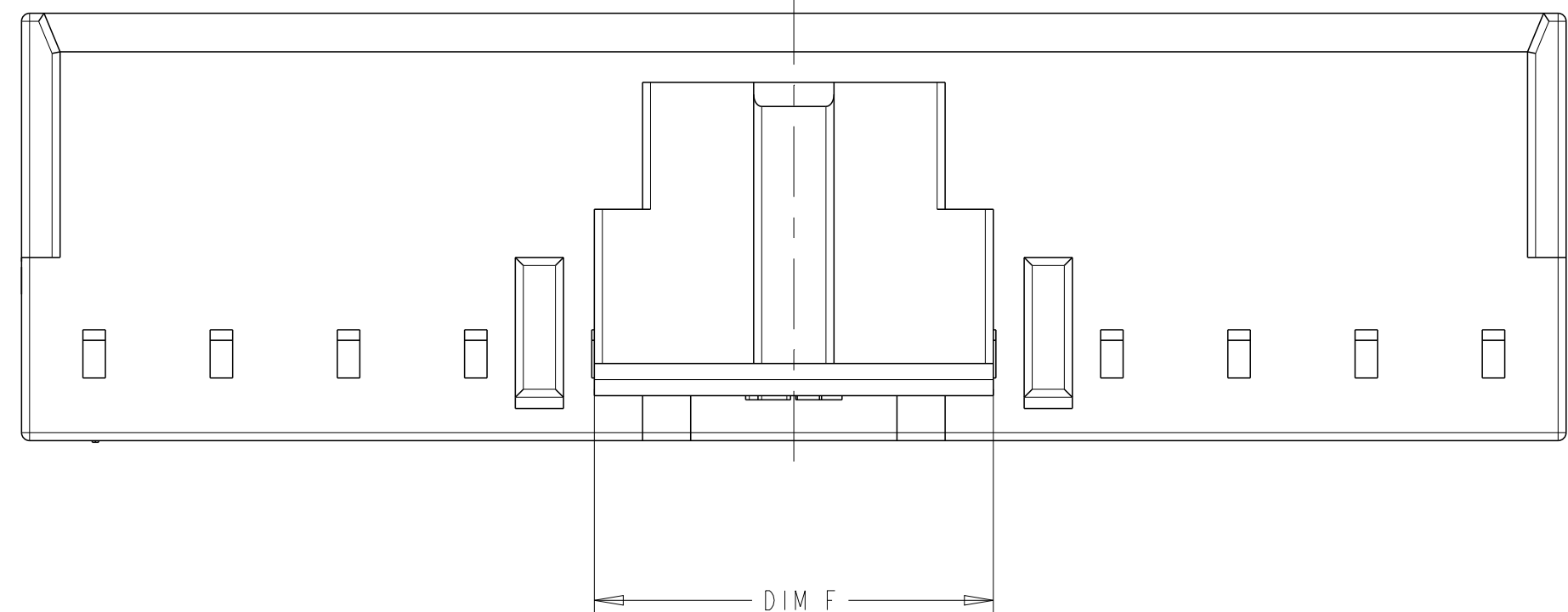
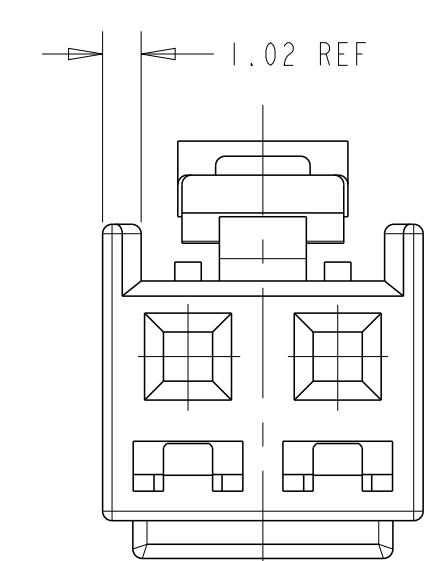
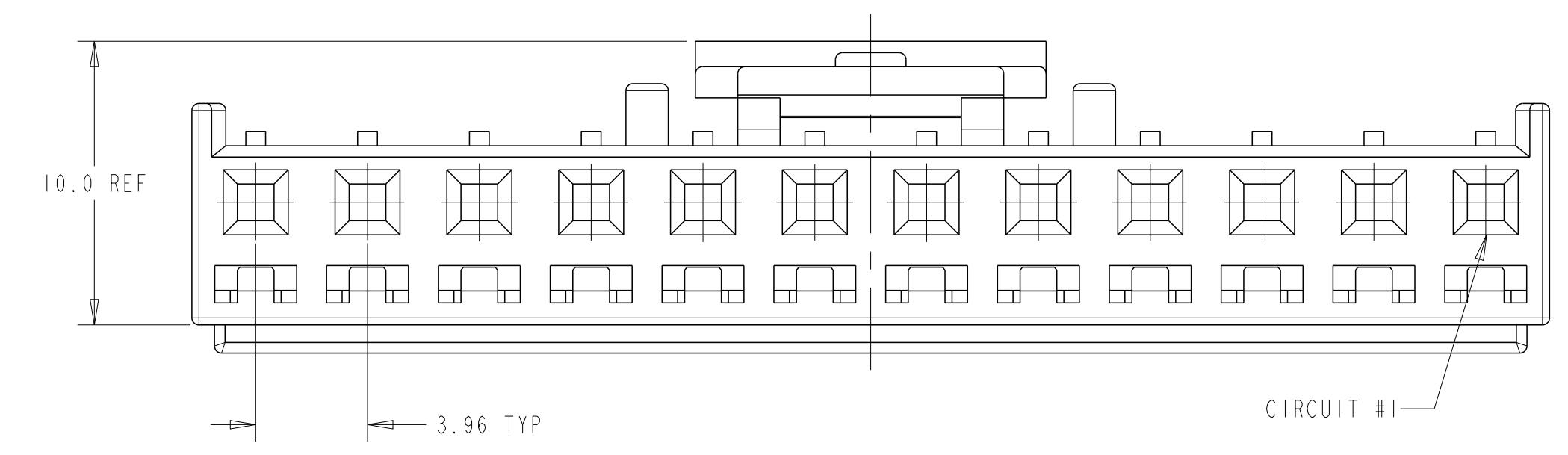
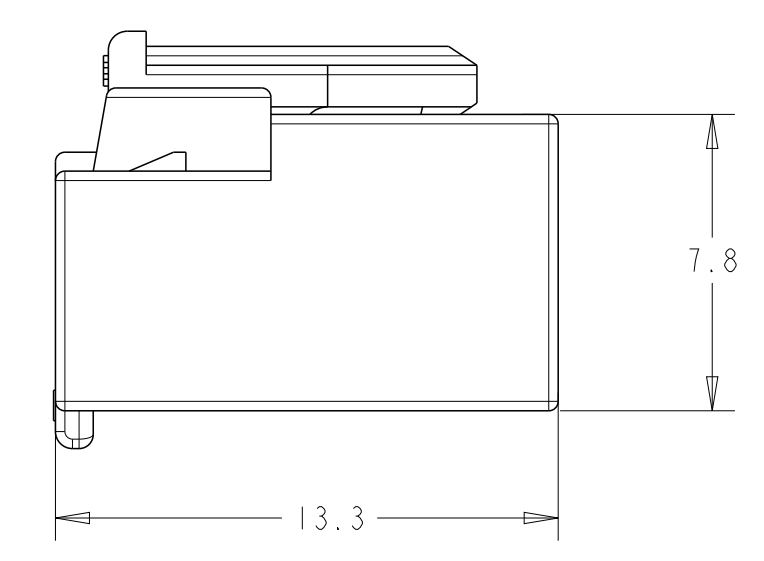

FRONT VIEW (2 POSITION SHOWN)

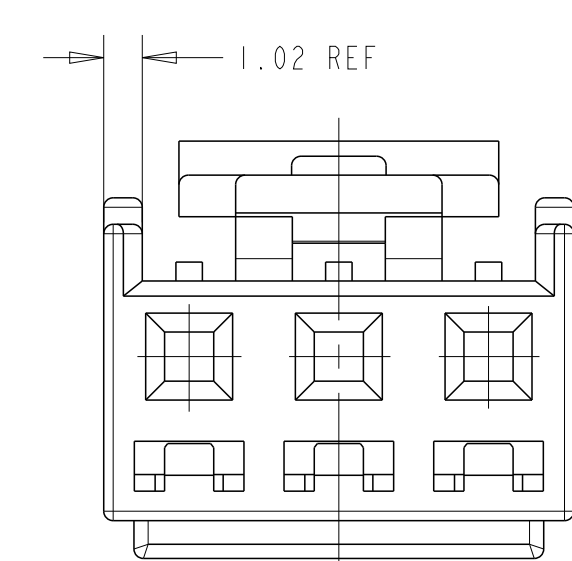

FRONT VIEW (3 POSITION SHOWN)

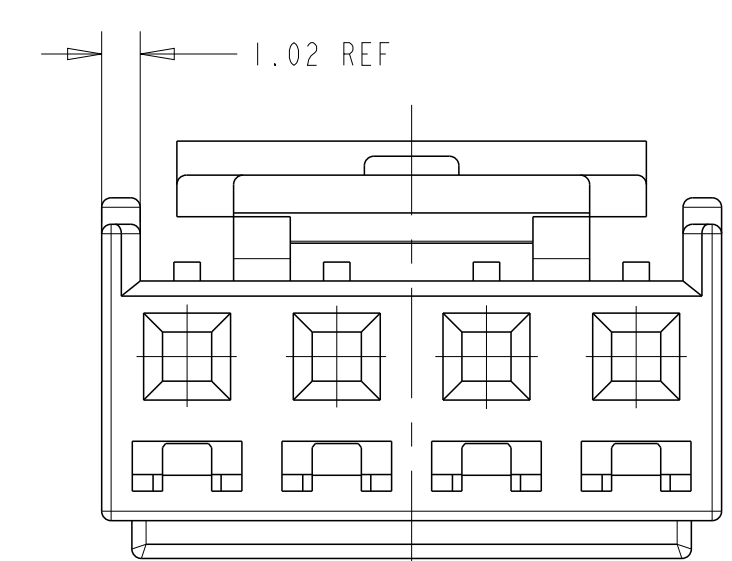

FRONT VIEW (4 POSITION SHOWN)

|       |       |                |             |
|-------|-------|----------------|-------------|
| 12.42 | 48.08 | 12             | 1-2371377-2 |
| 8.46  | 44.12 | 11             | 1-2371377-1 |
| 12.42 | 40.16 | 10             | 1-2371377-0 |
| 8.46  | 36.20 | 9              | 2371377-9   |
| 12.42 | 32.24 | 8              | 2371377-8   |
| 8.46  | 28.28 | 7              | 2371377-7   |
| 12.42 | 24.32 | 6              | 2371377-6   |
| 8.46  | 20.36 | 5              | 2371377-5   |
| 12.42 | 16.40 | 4              | 2371377-4   |
| 8.46  | 12.44 | 3              | 2371377-3   |
| 4.50  | 8.48  | 2              | 2371377-2   |
| DIM F | DIM A | NO OF POSITION | PART NUMBER |

THIS DRAWING IS A CONTROLLED DOCUMENT.

|             |  |                          |                         |
|-------------|--|--------------------------|-------------------------|
| DIMENSIONS: | TOLERANCES UNLESS OTHERWISE SPECIFIED: | DWN: W. HUO 01JUN2021    | CHK: D. ZHANG 03JUN2021 |
| mm          | 0 PLC ±0.4                             | APVD: D. ZHANG 03JUN2021 |                         |
|             | 2 PLC ±0.25                            | PRODUCT SPEC             |                         |
|             | 3 PLC ±0.25                            | APPLICATION SPEC         |                         |
|             | 4 PLC ±0.25                            | SIZE                     | 114-13265               |
|             | ANGLES ±°                              | WEIGHT                   | -                       |
| MATERIAL    | FINISH                                 | CAGE CODE                | 00779                   |
|             |  | DRAWING NO               | 2371377                 |
|             |  | RESTRICTED TO            |                         |
|             |  | CUSTOMER DRAWING         |                         |
|             |  | SCALE                    | N/A                     |
|             |  | SHEET                    | 1 OF 1                  |
|             |  | REV                      | A1                      |

TE Connectivity  
 NAME: RECEPTACLE HOUSING, GWT, SINGLE ROW, ECONOMY POWER 11  
 SIZE: 114-13265