

## N-channel 80 V, 3.5 mΩ typ., 90 A STripFET™ F7 Power MOSFET in a TO-220 package

Datasheet - production data

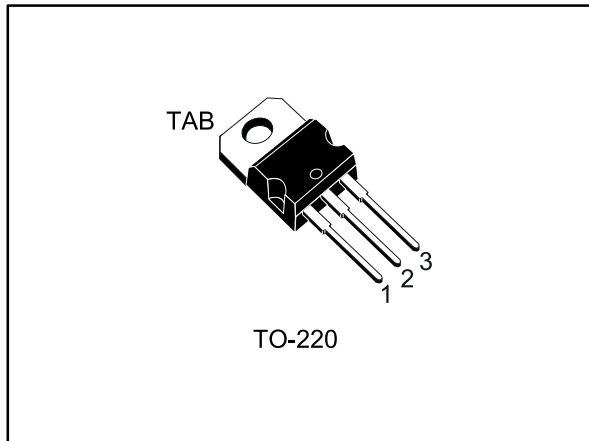
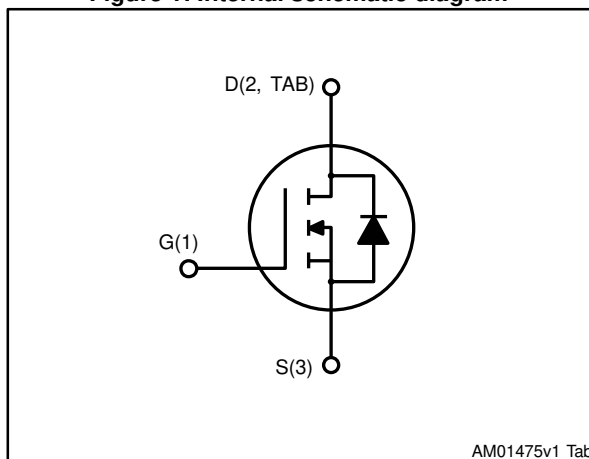

Figure 1: Internal schematic diagram



### Features

Order code	V <sub>DS</sub>	R <sub>DS(on)</sub> max.	I <sub>D</sub>	P <sub>TOT</sub>
STP140N8F7	80 V	4.3 mΩ	90 A	200 W

- Among the lowest R<sub>DS(on)</sub> on the market
- Excellent figure of merit (FoM)
- Low C<sub>rss</sub>/C<sub>iss</sub> ratio for EMI immunity
- High avalanche ruggedness

### Applications

- Switching applications

### Description

This N-channel Power MOSFET utilizes STripFET™ F7 technology with an enhanced trench gate structure that results in very low on-state resistance, while also reducing internal capacitance and gate charge for faster and more efficient switching.

Table 1: Device summary

Order code	Marking	Package	Packaging
STP140N8F7	140N8F7	TO-220	Tube

---

## Contents

<b>1</b>	<b>Electrical ratings .....</b>	<b>3</b>
<b>2</b>	<b>Electrical characteristics .....</b>	<b>4</b>
	2.1 Electrical characteristics (curves).....	6
<b>3</b>	<b>Test circuits .....</b>	<b>8</b>
<b>4</b>	<b>Package mechanical data .....</b>	<b>9</b>
	4.1 TO-220 type A package information.....	10
<b>5</b>	<b>Revision history .....</b>	<b>12</b>

# 1 Electrical ratings

**Table 2: Absolute maximum ratings**

Symbol	Parameter	Value	Unit
$V_{DS}$	Drain-source voltage	80	V
$V_{GS}$	Gate-source voltage	$\pm 20$	V
$I_D$	Drain current (continuous) at $T_C = 25\text{ °C}$	90 <sup>(1)</sup>	A
$I_D$	Drain current (continuous) at $T_C = 100\text{ °C}$	90	A
$I_{DM}$ <sup>(2)</sup>	Drain current (pulsed)	360	A
$P_{TOT}$	Total dissipation at $T_C = 25\text{ °C}$	200	W
$E_{AS}$ <sup>(3)</sup>	Single pulse avalanche energy	515	mJ
$T_j$	Operating junction temperature	- 55 to 175	°C
$T_{stg}$	Storage temperature		

**Notes:**

<sup>(1)</sup>Limited by package

<sup>(2)</sup>Pulse width is limited by safe operating area

<sup>(3)</sup>Starting  $T_j = 25\text{ °C}$ ,  $I_D = 18.5\text{ A}$ ,  $V_{DD} = 50\text{ V}$

**Table 3: Thermal data**

Symbol	Parameter	Value	Unit
$R_{thj-case}$	Thermal resistance junction-case	0.75	°C/W
$R_{thj-amb}$	thermal resistance junction-ambient	62.5	°C/W

## 2 Electrical characteristics

(T<sub>CASE</sub> = 25 °C unless otherwise specified)

**Table 4: On/off states**

Symbol	Parameter	Test conditions	Min.	Typ.	Max.	Unit
V <sub>(BR)DSS</sub>	Drain-source breakdown voltage	V <sub>GS</sub> = 0, I <sub>D</sub> = 250 μA	80			V
I <sub>DSS</sub>	Zero gate voltage Drain current	V <sub>GS</sub> = 0, V <sub>DS</sub> = 80 V			1	μA
		V <sub>GS</sub> = 0, V <sub>DS</sub> = 80 V, T <sub>J</sub> =125 °C			10	μA
I <sub>GSS</sub>	Gate-source leakage current	V <sub>DS</sub> = 0, V <sub>GS</sub> = ±20 V			±100	nA
V <sub>GS(th)</sub>	Gate threshold voltage	V <sub>DS</sub> = V <sub>GS</sub> , I <sub>D</sub> = 250 μA	2.5		4.5	V
R <sub>DS(on)</sub>	Static drain-source on-resistance	V <sub>GS</sub> =10 V, I <sub>D</sub> = 45 A		3.5	4.3	mΩ

**Table 5: Dynamic**

Symbol	Parameter	Test conditions	Min.	Typ.	Max.	Unit
C <sub>ISS</sub>	Input capacitance	V <sub>GS</sub> = 0, V <sub>DS</sub> = 40 V, f = 1 MHz	-	6340	-	pF
C <sub>OSS</sub>	Output capacitance		-	1195	-	pF
C <sub>RSS</sub>	Reverse transfer capacitance		-	105	-	pF
Q <sub>g</sub>	Total gate charge	V <sub>DD</sub> = 40 V, I <sub>D</sub> = 64 A, V <sub>GS</sub> = 10 V	-	96	-	nC
Q <sub>gs</sub>	Gate-source charge		-	30	-	nC
Q <sub>gd</sub>	Gate-drain charge		-	26	-	nC

**Table 6: Switching times**

Symbol	Parameter	Test conditions	Min.	Typ.	Max.	Unit
t <sub>d(on)</sub>	Turn-on delay time	V <sub>DD</sub> = 40 V, I <sub>D</sub> = 45 A R <sub>G</sub> =4.7 Ω, V <sub>GS</sub> = 10 V	-	26	-	ns
t <sub>r</sub>	Rise time		-	51	-	ns
t <sub>d(off)</sub>	Turn-off-delay time		-	82	-	ns
t <sub>f</sub>	Fall time		-	44	-	ns

Table 7: Source drain diode

Symbol	Parameter	Test conditions	Min.	Typ.	Max.	Unit
$I_{SD}$	Source-drain current		-		90	A
$I_{SDM}^{(1)}$	Source-drain current (pulsed)		-		360	A
$V_{SD}^{(2)}$	Forward on voltage	$V_{GS} = 0, I_{SD} = 90 \text{ A}$	-		1.2	V
$t_{rr}$	Reverse recovery time	$I_{SD} = 64 \text{ A}, di/dt = 100 \text{ A}/\mu\text{s},$ $V_{DD} = 60 \text{ V}$ $T_j = 150 \text{ }^\circ\text{C}$	-	58		ns
$Q_{rr}$	Reverse recovery charge		-	92		nC
$I_{RRM}$	Reverse recovery current		-	3.2		A

**Notes:**

(1) Pulse width is limited by safe operating area

(2) Pulse test: pulse duration = 300  $\mu\text{s}$ , duty cycle 1.5%

## 2.1 Electrical characteristics (curves)

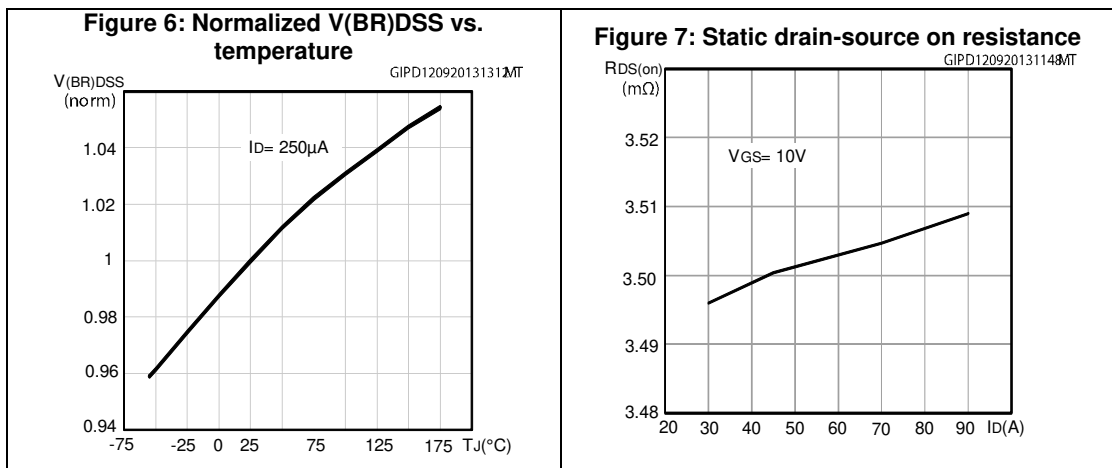
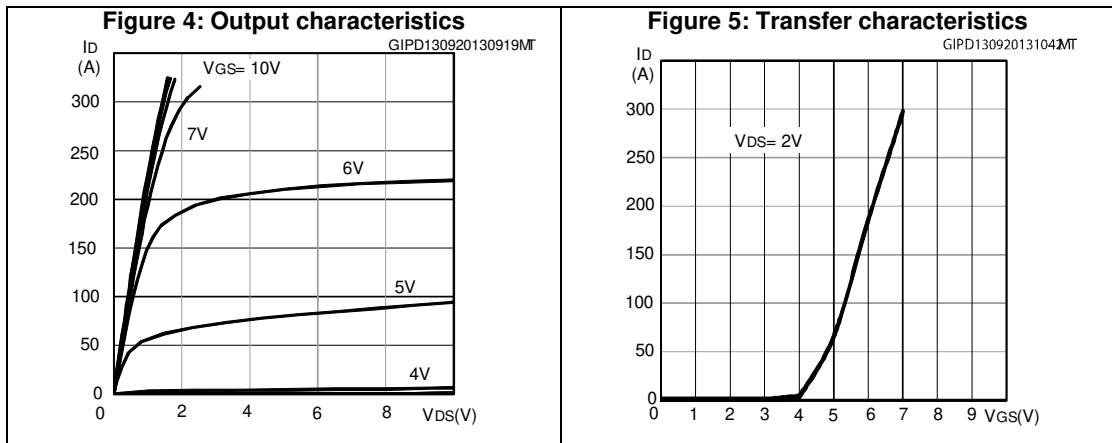
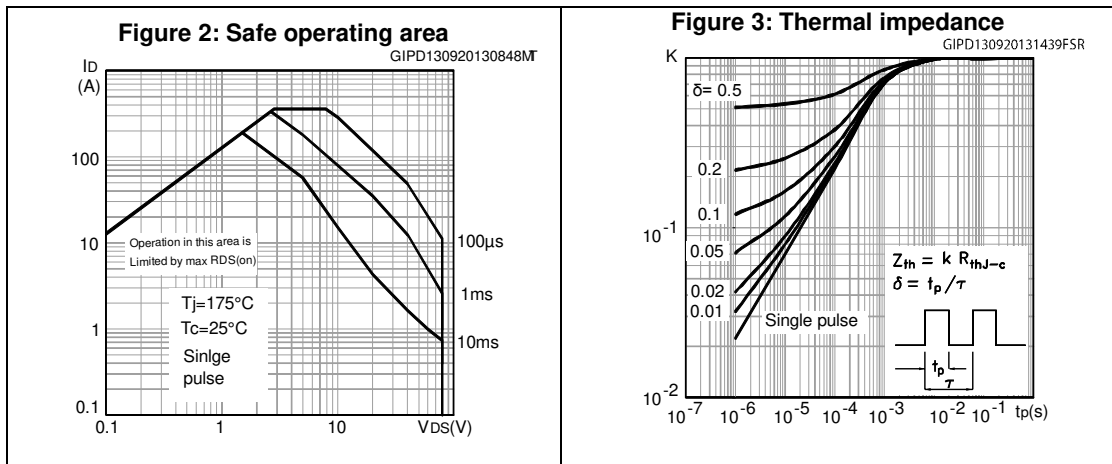

Figure 8: Gate charge vs. gate-source voltage

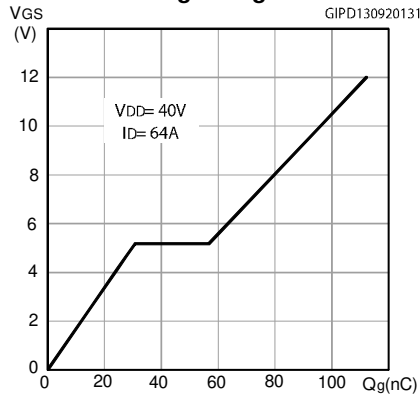

Figure 9: Capacitance variations

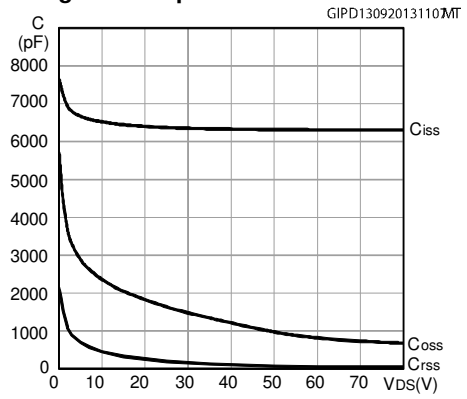

Figure 10: Normalized gate threshold voltage vs. temperature

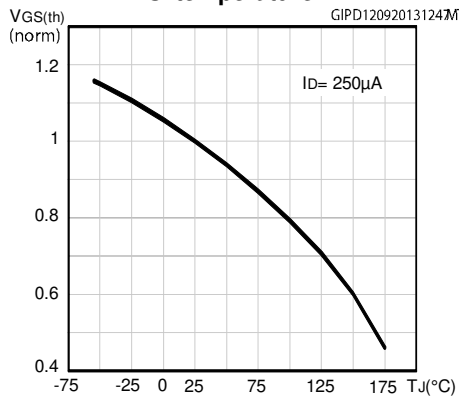

Figure 11: Normalized on resistance vs. temperature

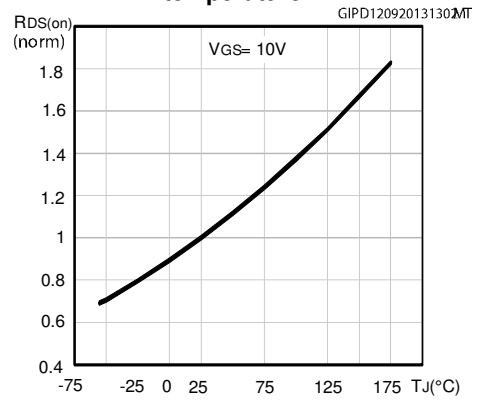
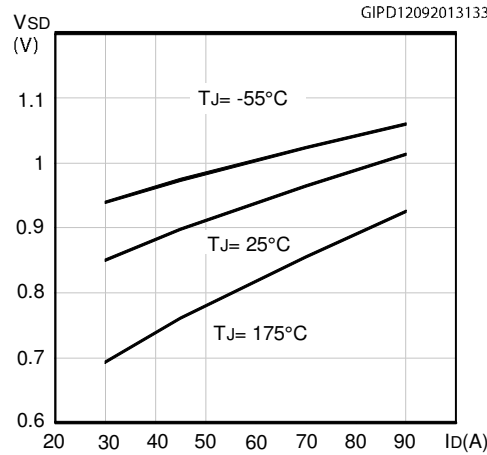
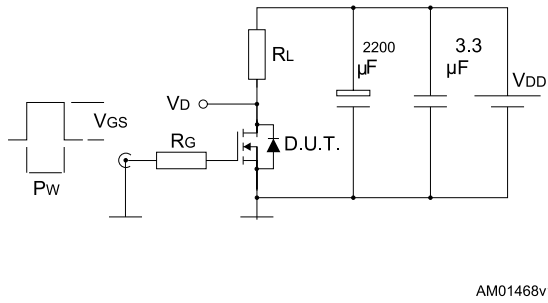

Figure 12: Source-drain diode forward characteristics



### 3 Test circuits

**Figure 13: Switching times test circuit for resistive load**



**Figure 14: Gate charge test circuit**

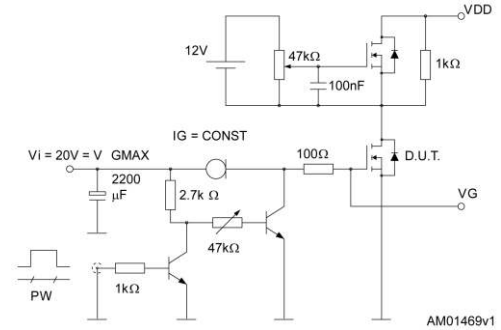

**Figure 15: Test circuit for inductive load switching and diode recovery times**

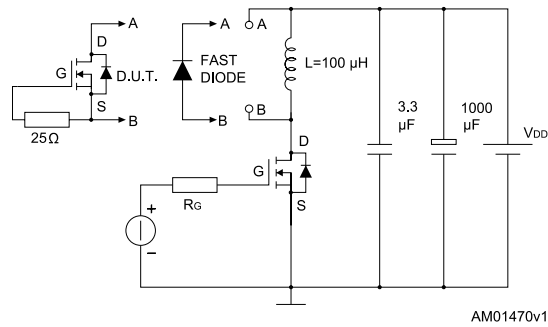

**Figure 16: Unclamped inductive load test circuit**

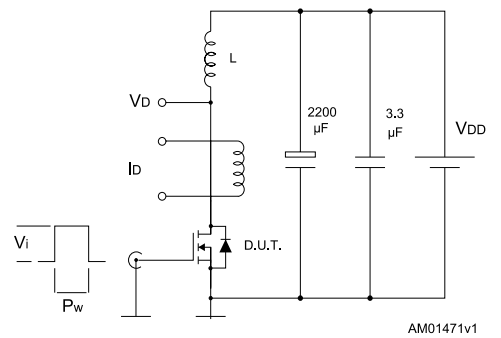

**Figure 17: Unclamped inductive waveform**

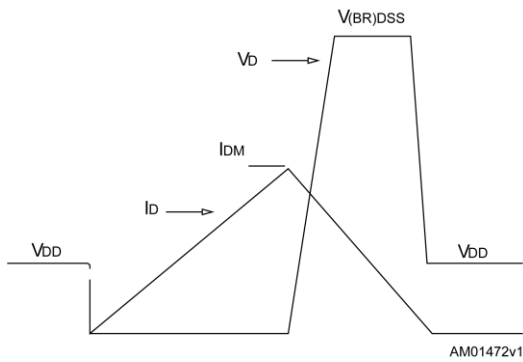

**Figure 18: Switching time waveform**

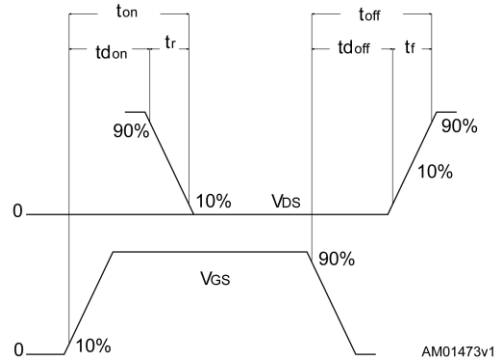



## 4 Package mechanical data

In order to meet environmental requirements, ST offers these devices in different grades of ECOPACK® packages, depending on their level of environmental compliance. ECOPACK® specifications, grade definitions and product status are available at: [www.st.com](http://www.st.com). ECOPACK® is an ST trademark.

### 4.1 TO-220 type A package information

Figure 19: TO-220 type A package outline

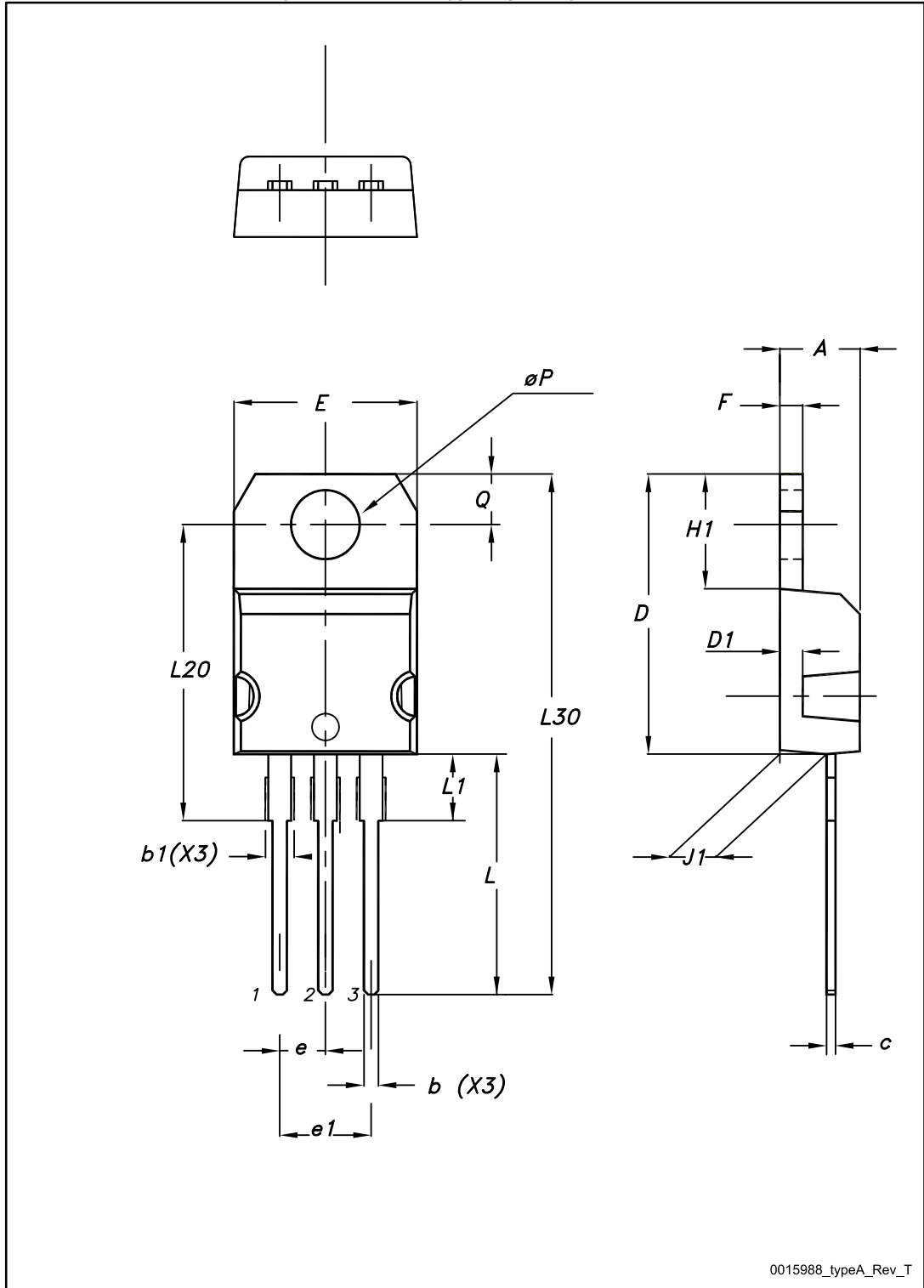

0015988\_typeA\_Rev\_T

Table 8: TO-220 type A mechanical data

Dim.	mm		
	Min.	Typ.	Max.
A	4.40		4.60
b	0.61		0.88
b1	1.14		1.70
c	0.48		0.70
D	15.25		15.75
D1		1.27	
E	10		10.40
e	2.40		2.70
e1	4.95		5.15
F	1.23		1.32
H1	6.20		6.60
J1	2.40		2.72
L	13		14
L1	3.50		3.93
L20		16.40	
L30		28.90	
ÆP	3.75		3.85
Q	2.65		2.95

## 5 Revision history

Table 9: Document revision history

Date	Revision	Changes
25-Aug-2014	1	First release.
09-Oct-2014	2	Updated <a href="#">Figure 3: "Thermal impedance"</a>

**IMPORTANT NOTICE – PLEASE READ CAREFULLY**

STMicroelectronics NV and its subsidiaries ("ST") reserve the right to make changes, corrections, enhancements, modifications, and improvements to ST products and/or to this document at any time without notice. Purchasers should obtain the latest relevant information on ST products before placing orders. ST products are sold pursuant to ST's terms and conditions of sale in place at the time of order acknowledgement.

Purchasers are solely responsible for the choice, selection, and use of ST products and ST assumes no liability for application assistance or the design of Purchasers' products.

No license, express or implied, to any intellectual property right is granted by ST herein.

Resale of ST products with provisions different from the information set forth herein shall void any warranty granted by ST for such product.

ST and the ST logo are trademarks of ST. All other product or service names are the property of their respective owners.

Information in this document supersedes and replaces information previously supplied in any prior versions of this document.

© 2014 STMicroelectronics – All rights reserved