

High Leverage Center Cutters

DIN ISO 5743

74
91

- > forged-on axle for heavy-duty cutting
- > precision cutting edges for soft, hard and piano wire
- > cuts thick wires with less effort than other diagonal cutters of the same length
- > cutting edges are in the center of the cutter head
- > high cutting performance with minimum effort due to optimum coordination of the cutting edge angle and transmission ratio
- > cutting edge hardness (approx. 64 HRC)
- > chrome vanadium heavy-duty steel; forged, multi stage oil-hardened



Cutting edges in the center of the cutter head



74 91 250



Product Number	Packaging	↔ Inch mm	Pliers	Head	Handles	Cutting capacities				⚖ lbs	
						Ø Inch Ø mm	Ø Inch Ø mm	Ø Inch Ø mm	Ø Inch Ø mm		
74 91 250	X	10 250	✚	black atramentized	polished	plastic coated	13/64 5.0	13/64 5.0	5/32 3.8	9/64 3.5	0.87

Diagonal Cutters

for electromechanics

DIN ISO 5749

76

- > with sharp, precisely aligned cutting edges for soft, hard wire and piano wire
- > cutting edge hardness (approx. 63 HRC)
- > lap joint
- > vanadium steel; forged, multi stage oil-hardened in multiple steps

76 12 125

Low-friction double spring for gentle and even opening

76 22 125

Without bevel for flush cutting of soft wires; low-friction double spring for gentle and even opening

76 81 125

Particularly tapered head with small bevel for work in confined areas (cable harnesses, multi-stranded wires)

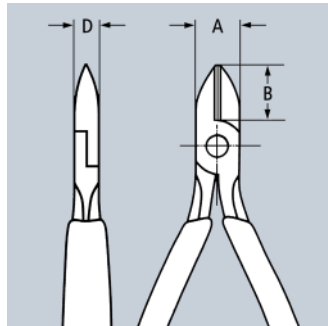

76 01 125



76 12 125



76 22 125



76 81 125



Product Number	Packaging	↔ Inch mm	Pliers	Head	Handles	Cutting capacities				Dimensions			⚖ lbs	
						Ø Inch Ø mm	Ø Inch Ø mm	Ø Inch Ø mm	Ø Inch Ø mm	A Inch mm	B Inch mm	D Inch mm		
76 01 125		5 125	✚	black atramentized	polished	plastic coated	1/64 - 1/8 0.4 - 3.0	3/32 2.3	1/16 1.5	1/32 0.6	37/64 14.5	5/8 16.0	23/64 9.0	0.20
76 12 125		5 125	✚	black atramentized	polished	multi-component grips	1/64 - 3/32 0.4 - 2.5	5/64 1.8	3/64 1.0	1/32 0.6	37/64 14.5	5/8 16.0	23/64 9.0	0.25
76 22 125		5 125	✚	black atramentized	polished	multi-component grips	1/64 - 3/32 0.4 - 2.5	-	-	-	37/64 14.5	5/8 16.0	23/64 9.0	0.24
76 81 125		5 125	✚	black atramentized	polished	plastic coated	1/64 - 1/16 0.4 - 1.7	3/64 1.3	1/32 0.8	-	37/64 14.5	5/8 16.0	23/64 9.0	0.19